

Made in Italy

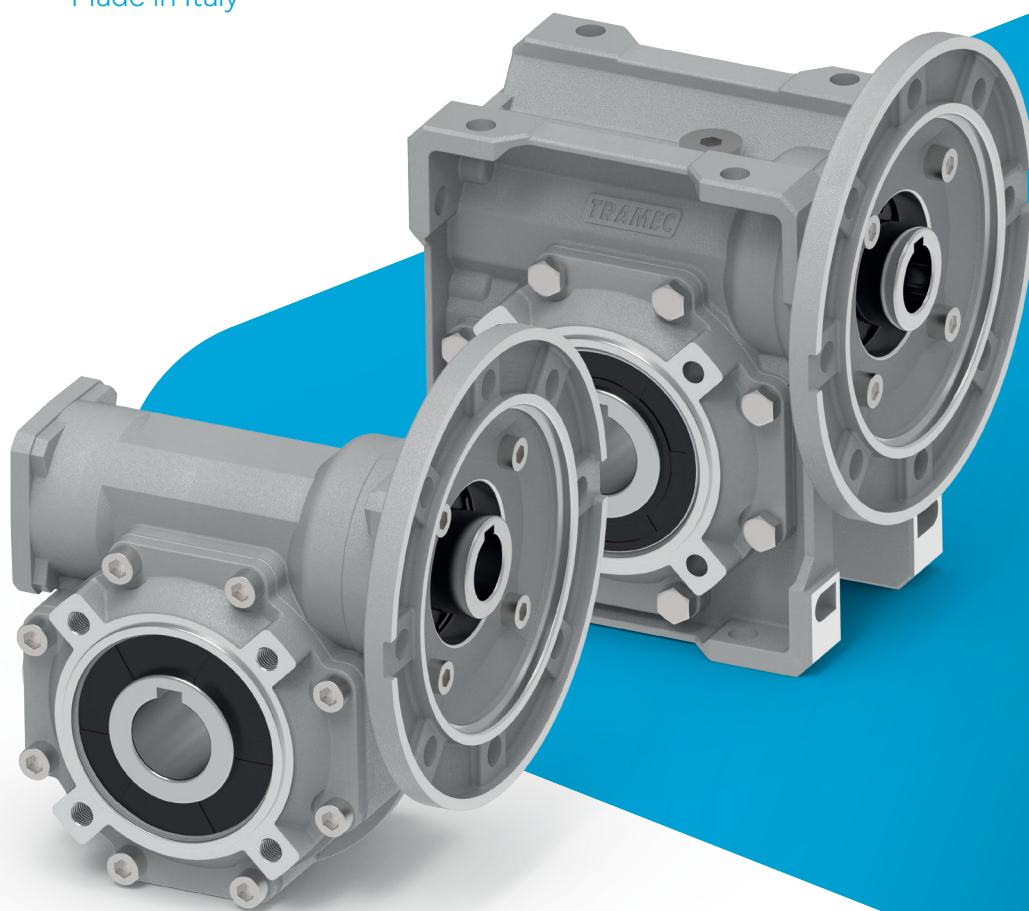

# RIDUTTORI A VITE SENZA FINE

*Worm gearboxes*  
*Schneckengetriebe*

X | K | H | XX-KX-KK | VM | N | UDL





Il gruppo MOONIND, che vede insieme:

TRAMEC srl, BERMAR, MT MOTORI ELETTRICI srl e VARMEC srl vanta una presenza in ben 68 paesi nei 5 continenti per occupare una posizione di spicco nel settore.

Le aziende produttive del gruppo e le relative filiali rappresentano un vero e proprio presidio territoriale di carattere commerciale e logistico ed affiancano il cliente con attività di pre e postvendita, partendo dalla fase di progettazione e coprendo l'intero ciclo di vita del prodotto.

Questa organizzazione permette al gruppo di proporsi quale fornitore completo e versatile, in grado di realizzare personalizzazioni di prodotto su richiesta.

Un partner attento all'ascolto e in grado di proporre soluzioni adeguate alle esigenze del cliente. Siamo in grado di affrontare tempestivamente ed in modo altamente professionale le diverse sfide del mercato nel mondo delle trasmissioni meccaniche. Possiamo fornire soluzioni complete per l'automazione.

*The MOONIND Group, gathering together TRAMEC Srl, BERMAR, MT ELECTRIC MOTORS, and VARMEC Srl, boasts a presence in 68 countries across 5 continents, which makes it a leading company in the industry.*

*The Group's manufacturing facilities together with the sales branches represent a real territorial presence which guarantees both sales and logistical support to customers through pre- and after-sales activities, starting from the design phase and covering the entire life cycle of the products being manufactured.*

*This organization allows the Moonind Group to present itself as a complete and dynamic supplier, capable of providing customized products based on customers' needs. We are able to deal promptly and professionally with the various challenges set by the market in the mechanical transmission related field. We can provide complete solutions for automation.*

Die MOONIND-Gruppe, zu der TRAMEC Srl, BERMAR, MT ELECTRIC MOTORS und VARMEC Srl gehören, ist in 68 Ländern auf 5 Kontinenten vertreten und hat sich somit eine führende Position in der Branche erarbeitet.

Die Produktionsgesellschaften der Gruppe sowie ihre Tochterunternehmen garantieren eine starke lokale Präsenz sowohl im kommerziellen als auch im logistischen Bereich. Sie unterstützen die Kunden mit umfassenden Leistungen vor und nach dem Verkauf, beginnend in der Entwurfsphase und begleitend den gesamten Produktlebenszyklus.

Dank dieser Struktur positioniert sich die Moonind-Gruppe als ein kompetenter und flexibler Anbieter, der in der Lage ist, Produkte exakt an die Bedürfnisse seiner Kunden anzupassen. Wir sind in der Lage, die vielfältigen Anforderungen des Marktes im Bereich der mechanischen Antriebstechnik schnell und professionell zu meistern. Unsere Lösungen für die Automatisierung sind ganzheitlich und auf die individuellen Bedürfnisse unserer Kunden abgestimmt.

  
MOVING ON INDUSTRIES

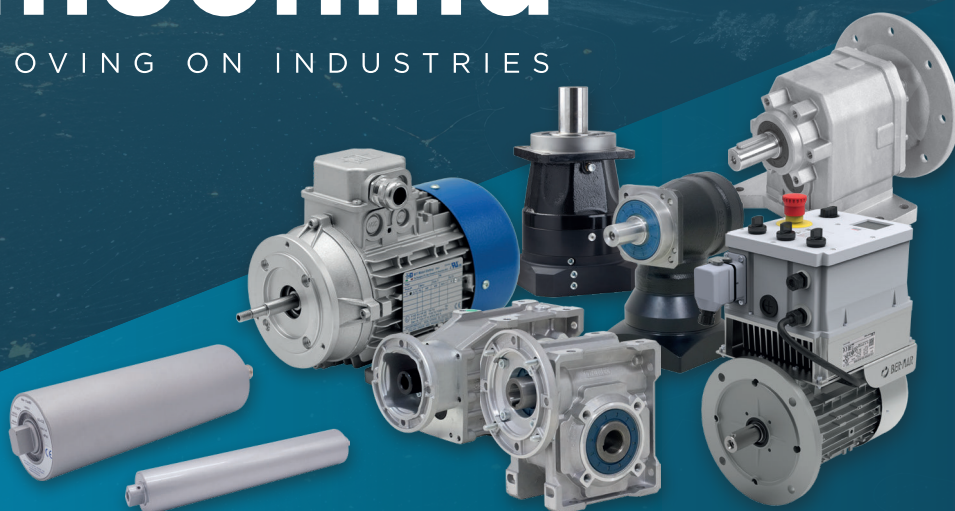

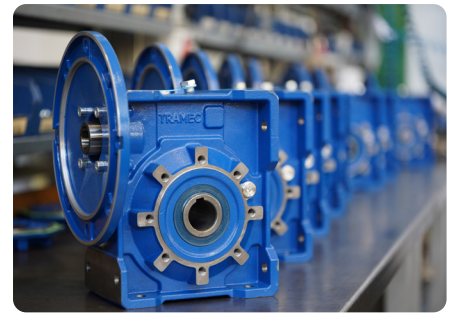

## Vision aziendale

La filosofia di **TRAMEC** è da sempre incentrata sui seguenti punti cardine:

- Il perseguimento dell'eccellenza produttiva e qualitativa con una produzione rigorosamente **100% MADE IN ITALY**.
- Il fattore umano nel rapporto con i dipendenti, clienti e collaboratori.
- La ricerca continua di soluzioni innovative.

## Company Vision

*TRAMEC's philosophy has always been centred on the following cornerstones:*

- *The pursuit of production and quality excellence with strictly **100% production MADE IN ITALY**.*
- *The human factor in the relationship with employees, customers and collaborators.*
- *The continuous search for innovative solutions.*

## Unternehmensphilosophie

Die Philosophie von **TRAMEC** basiert seit jeher auf den folgenden Eckpfeilern:

- Das Streben nach hervorragender Produktion und Qualität mit konsequent **100% iger Produktion MADE IN ITALY**.
- Der menschliche Faktor im Umgang mit Mitarbeitern, Kunden und Kooperationspartnern.
- Die ständige Suche nach innovativen Lösungen.

## Mission aziendale

- Essere un partner di riferimento a livello internazionale per la progettazione, realizzazione e commercializzazione di soluzioni avanzate ed affidabili nel settore delle trasmissioni di potenza.
- Fornire ai clienti un supporto rapido e puntuale, dalla fase di progettazione fino al post-vendita.
- Continuo miglioramento dei processi e prestazioni nel proprio Sistema di Gestione Integrata.

## Company Mission

- *To be an international reference partner for the design, realisation and marketing of advanced and reliable solutions in the power transmission sector.*
- *Providing customers with fast and timely support, from the design phase to after-sales.*
- *Continuous improvement of processes and performance in its Integrated Management System.*

## Mission des Unternehmens

- Ein internationaler Referenzpartner für die Planung, Realisierung und Vermarktung von fortschrittlichen und zuverlässigen Lösungen im Bereich der Energieübertragung zu sein.
- Schnelle und rechtzeitige Unterstützung der Kunden von der Entwurfsphase bis zum After-Sales-Service zu gewährleisten.
- Kontinuierliche Verbesserung der Prozesse und Leistungen im Rahmen des integrierten Managementsystems zu erzielen.

## Ambiente, salute e sicurezza

**TRAMEC** si distingue tramite una produzione che rispetta l'ambiente e si attiene alle direttive e alle norme nel rispetto di tutti gli stakeholders. Ciò significa la riduzione del consumo di materie prime, l'impiego efficiente dell'energia, l'utilizzo attento e responsabile delle sostanze inquinanti, la diminuzione dell'emissione dei rifiuti e l'attuazione di tutte le forme di sicurezza sul lavoro.

## Environment, health and safety

*TRAMEC distinguishes itself through environmentally friendly production and adheres to guidelines and standards in respect of all stakeholders. This means the reduction of raw material consumption, the efficient use of energy, and the careful and responsible use of pollutants, the reduction of waste emissions and the implementation of all forms of occupational safety.*

## Umwelt, Gesundheit und Sicherheit

**TRAMEC** zeichnet sich durch eine umweltfreundliche Produktion aus und hält sich an Richtlinien und Standards gegenüber allen Beteiligten. Das bedeutet die Reduzierung des Rohstoffverbrauchs, die effiziente Nutzung von Energie und den sorgfältigen und verantwortungsvollen Umgang mit Schadstoffen, die Verringerung der Abfallemissionen und die Umsetzung aller Formen des Arbeitsschutzes.

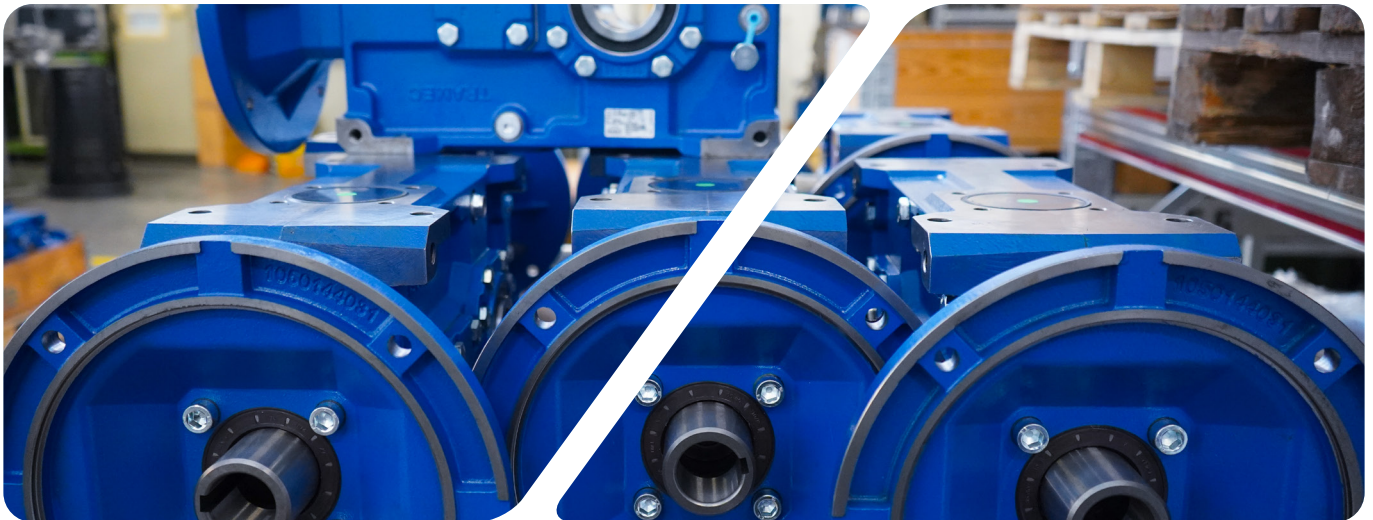

## Riduttori per ogni esigenza

**TRAMEC** nasce nel 1986 a Calderara di Reno, nel cuore della cosiddetta "Motor Valley", una porzione di territorio compresa tra Bologna e Modena celebre per essere la patria delle eccellenze del **MADE IN ITALY** nei settori automobilistico, motociclistico e della meccanica di precisione.

Fin dalla sua fondazione, **TRAMEC** si è specializzata nella produzione di riduttori ad ingranaggi ad alberi ortogonali, paralleli, pendolari e di rinvii angolari, ampliando nel tempo la propria gamma con nuove linee di prodotto come i riduttori epicicloidali di precisione ed i riduttori a vite senza fine. Successivamente l'offerta è stata ampliata con i motori elettrici e gli azionamenti per l'automazione.

L'obiettivo dell'azienda è quello di fronteggiare un mercato in continua evoluzione sul piano delle strategie di competitività qualitativa, economica e di presenza, attraverso un adeguato supporto offerto da tutti i propri reparti (produzione, tecnico e commerciale) e di una rete vendita ramificata e altamente competente.

Nel 2024, nasce il **gruppo MOONIND**: che vede insieme **TRAMEC**, **BERMAR**, **MT** e **VARMEC**. **MOONIND**: rappresenta la fusione di competenze complementari: dai riduttori di velocità ai motori elettrici, passando per i sistemi di motion control e le soluzioni innovative per la trasmissione di potenza. Con questo passaggio sinergico, non siamo più "solo" produttori di singoli componenti, ma un partner integrato in grado di offrirvi soluzioni complete per l'automazione industriale.

## Gearboxes for every need

**TRAMEC** was founded in 1986 in Calderara di Reno, in the heart of the so-called "Motor Valley", a portion of territory between Bologna and Modena famous for being the home of **MADE IN ITALY** excellence in the automotive, motorbike and precision mechanics sectors.

Since its foundation, **TRAMEC** has specialised in the production of orthogonal, parallel and shaft-mounted gearboxes and bevel gearboxes, expanding its range over time with new product lines such as precision planetary gearboxes and worm gearboxes. Subsequently, the offer was expanded with electric motors and drives for automation.

The company's aim is to cope with an ever-changing market in terms of qualitative, economic and presence competitiveness strategies through adequate support offered by all its departments (production, technical and commercial) and a branched and highly competent sales network.

In 2024, the moonind group was born: which sees **TRAMEC**, **BERMAR**, **MT** and **VARMEC** together. **MOONIND**: represents the fusion of complementary skills: from speed reducers to electric motors, including motion control systems and innovative solutions for power transmission. With this synergistic step, we are no longer "only" manufacturers of individual components, but an integrated partner able to offer you complete solutions for industrial automation.

## Getriebe für jedes Bedürfnis

**TRAMEC** wurde 1986 in Calderara di Reno gegründet, im Herzen des so genannten "Motor Valley", einem Gebiet zwischen Bologna und Modena, das als Heimat der **MADE IN ITALY-Exzellenz** in den Bereichen Automobil, Motorrad und Feinmechanik bekannt ist.

Seit seiner Gründung hat sich **TRAMEC** auf die Herstellung von Kegelrad-, Stirnrad- und Aufsteckgetrieben sowie Winkelgetrieben spezialisiert und sein Angebot im Laufe der Zeit um neue Produktlinien wie Präzisionsplanetengetriebe und Schneckengetriebe erweitert. Später wurde das Angebot um Elektromotoren und Antriebe für die Automatisierung erweitert.

Das Ziel des Unternehmens ist es, einem sich hinsichtlich der Strategien qualitativer, wirtschaftlicher und präserter Wettbewerbsfähigkeit ständig verändernden Markt durch angemessene Unterstützung aller Abteilungen (Produktion, Technik und Handel) und ein verzweigtes und hochkompetentes Vertriebsnetz zu stellen.

Im Jahr 2024 wurde die **MOONIND-Gruppe** gegründet, die **TRAMEC**, **BERMAR**, **MT** und **VARMEC** vereint. Moonind steht für die Fusion komplementärer Kompetenzen: von Getriebemotoren über Elektromotoren bis hin zu Motion-Control-Systemen und innovativen Lösungen für die Antriebstechnik. Mit diesem synergetischen Schritt sind wir nicht mehr „nur“ Hersteller einzelner Komponenten, sondern ein integrierter Partner, der Ihnen komplette Lösungen für die industrielle Automatisierung anbieten kann.

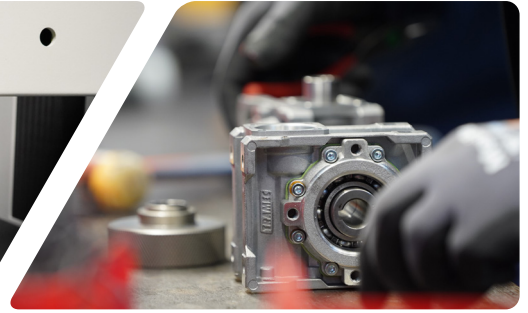
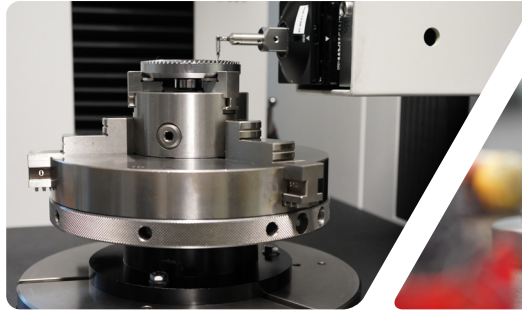
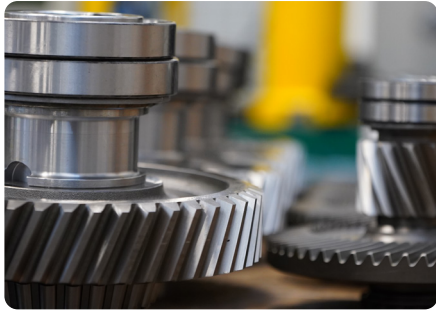

### Siti produttivi

Production sites  
Produktionsstätten

### Filiali Italia

Italian Branches  
Niederlassungen in Italien

### Filiali Estere

Foreign Branches  
Ausländische Niederlassungen



### Tramec

**Tramec srl**  
Via Bizzarri, 6  
40012 - Calderara di Reno  
Bologna (Italy)  
tramec.it

### Ital.Tech srl

Via C. Bozza SNC  
06073 Ellera di Corciano  
Perugia (Italy)  
www.italtech.info

### Tramec Getriebe gmbh

Senefelderstraße, 3  
77933 Lahr  
Germany  
www.tramec-getriebe.de



### Varmec

**Varmec srl**  
Via dell'Industria, 13  
36016 - Thiene  
Vicenza (Italy)  
varmec.com

### Tramec Sud srl

Via Gorga, 17  
Zona Industriale - LOTTO 17  
80036 Palma Campania  
Napoli (Italy)  
www.tramecsud.it

### Sarl Tramec France

145 Impasse des clos  
ZAE Planbois  
74550 Perrignier  
France  
www.tramec.fr



### MT

ELECTRIC  
MOTORS



### Bermar

**MT Motori Elettrici srl**  
via Bologna, 175  
40017 - San Giovanni in Persiceto  
Bologna (Italy)  
electricmotorsmt.com  
bermar.it

### Tramec Technology srl

Via Leonardo da Vinci, 179  
24043 Caravaggio  
Bergamo (Italy)  
www.tramectechnology.it

### Tramec Polska SP. ZOO

Śloneczna, 1  
66-130 Bojadła  
Poland  
www.tramec.pl

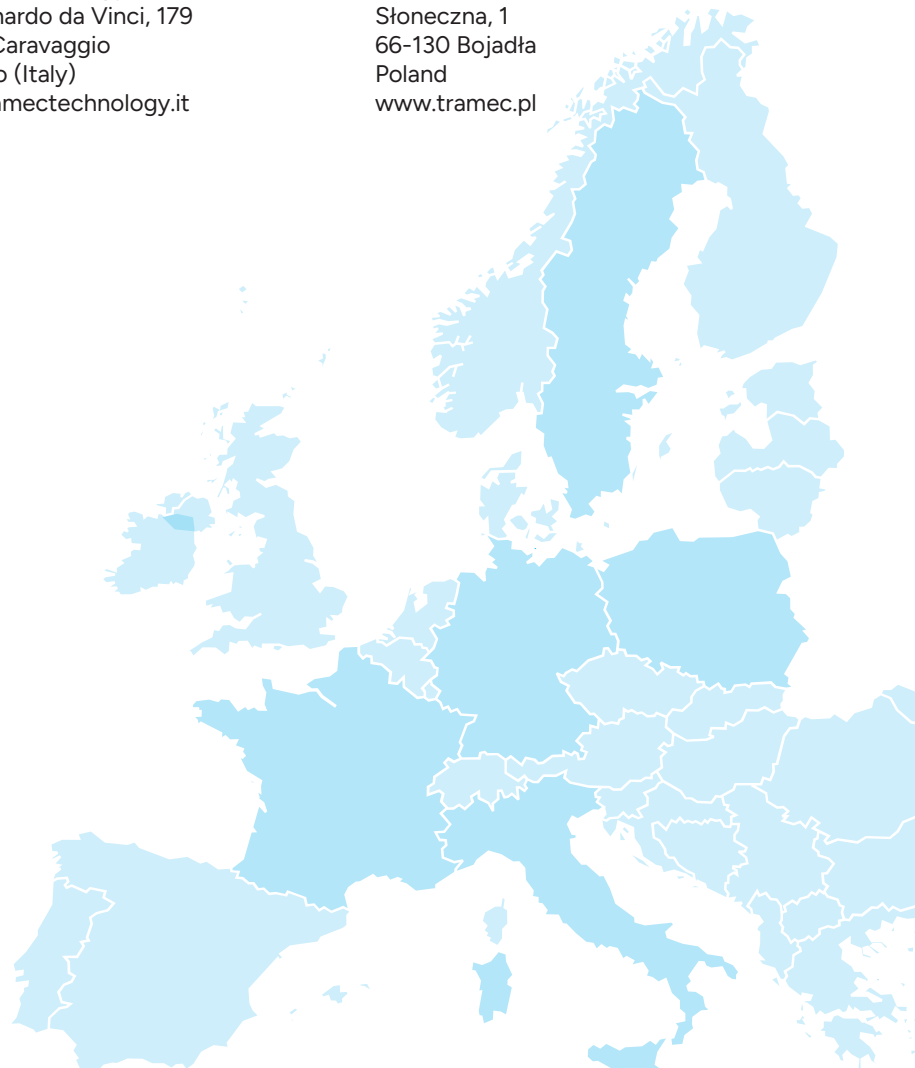

## Gamma prodotti

I prodotti **TRAMEC** coprono una vasta gamma di esigenze, e sono presenti in diverse applicazioni.

Robotica, automazione macchine utensili, macchine per la stampa, macchine automatiche per confezionamento ed imballaggio, manipolatori, macchine serigrafiche, guide lineari, macchine per lavorazione del legno sono alcuni degli esempi dove trovano utilizzo.

## Product range

**TRAMEC** products cover a wide range of needs, and can be found in various applications.

Robotics, machine tool automation, printing machines, automatic wrapping and packaging machines, manipulators, screen printing machines, linear guides, woodworking machines are some of the examples where they are used.

## Produktbereich

Die Produkte von **TRAMEC** decken eine breite Palette von Bedürfnissen ab und sind in verschiedenen Anwendungen zu finden.

Robotik, Automatisierung von Werkzeugmaschinen, Druckmaschinen, automatische Verpackungsmaschinen, Manipulatoren, Siebdruckmaschinen, Linearführungen, Maschinen für die Holzbearbeitung sind einige Beispiele für die Anwendung.

## TRAMEC

### Riduttori ad ingranaggi ortogonali e paralleli

*Gear reducers orthogonal and parallel*

Rechtwinklige und parallele Untersetzungsgetriebe



### Riduttori a vite senza fine

*Worm gear reducers*

Schneckengetriebe

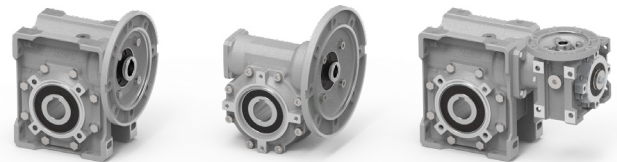

### Riduttori epicicloidali

*Planetary gearboxes*

Planetengetriebe



### Riduttori linea GHA

*GHA line reducers*

GHA-Leitungsreduzierer



## BERMAR

Prodotti / Products / Produkte

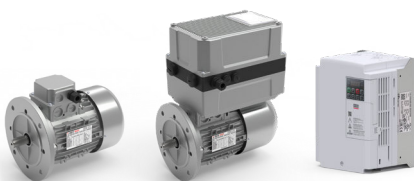

## MT Motori elettrici

Prodotti / Products / Produkte



## VARMEC

Prodotti / Products / Produkte

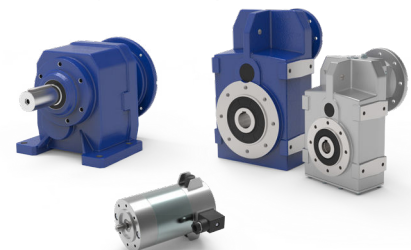

Il presente catalogo annulla e  
sostituisce i precedenti.

**I dati riportati nel presente catalogo sono  
indicativi e non impegnativi.**

La **TRAMEC srl** si riserva di modificare  
dati numerici, disegni ed ogni altra  
informazione contenuta nel presente  
documento senza preavviso alla gentile  
clientela.

*This catalogue cancels and replaces the  
previous ones.*









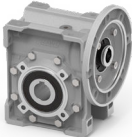

***The data in this catalogue is indicative  
and not binding.***

***TRAMEC srl reserves to change the  
numbers, drawings and any other  
information contained in this document  
without prior notice to customers.***

Dieser Katalog annulliert und ersetzt die  
vorhergehenden Kataloge.

**Die Angaben in diesem Katalog sind  
unverbindlich.**

**TRAMEC srl** behält sich das Recht  
vor, numerische Daten, Zeichnungen  
und alle anderen in diesem Dokument  
enthaltenen Informationen ohne  
vorherige Ankündigung an die Kunden  
zu ändern.

	INDICE	INDEX	INHALTSVERZEICHNIS	
	<b>GENERALITÀ</b>	<b>GENERAL INFORMATION</b>	<b>ALLGEMEINES</b>	
	Unità di misura	<i>Measurement units</i>	Maßeinheiten	<b>A8</b>
	Fattore di servizio	<i>Service factor</i>	Betriebsfaktor	<b>A8</b>
	Potenza	<i>Power</i>	Leistung	<b>A10</b>
	Rapporto di riduzione	<i>Reduction Ratio</i>	Untersetzungsverhältnis	<b>A10</b>
	Momento torcente	<i>Torque</i>	Drehmoment	<b>A10</b>
	Rendimento	<i>Efficiency</i>	Wirkungsgrad	<b>A11</b>
	Irreversibilità	<i>Irreversibility</i>	Selbsthemmung	<b>A12</b>
	Gioco angolare	<i>Backlash</i>	Winkelspiel	<b>A13</b>
	Senso di rotazione	<i>Direction of rotation</i>	Drehrichtung	<b>A14</b>
	Carichi radiali	<i>Radial load</i>	Radialbelastungen	<b>A14</b>
	Potenza termica	<i>Thermal power</i>	Thermische Leistung	<b>A17</b>
	Selezione	<i>Selection</i>	Wahl	<b>A18</b>
	Lubrificazione	<i>Lubrication</i>	Ölschmierung	<b>A19</b>
	Installazione	<i>Installation</i>	Einbau	<b>A21</b>
	Manutenzione	<i>Maintenance</i>	Wartung	<b>A21</b>
	Verniciatura	<i>Painting</i>	Lackierung	<b>A21</b>
	<b>X</b> RIDUTTORI A VITE SENZA FINE	<b>WORM GEARBOXES</b>	<b>SCHNECKENGETRIEBE</b>	<b>B1</b>
	<b>K</b> RIDUTTORI A VITE SENZA FINE	<b>WORM GEARBOXES</b>	<b>SCHNECKENGETRIEBE</b>	<b>C1</b>
	<b>H</b> RIDUTTORI A VITE SENZA FINE CON PRECOPPIA	<b>HELICAL WORM GEARBOXES</b>	<b>STIRNRAD- SCHNECKENGETRIEBE</b>	<b>D1</b>
	<b>KKC</b> RIDUTTORI A VITE SENZA FINE COMBINATI	<b>COMBINED WORM GEARBOXES</b>	<b>KOMBINIERT- SCHNECKENGETRIEB</b>	<b>E1</b>
	<b>KXC</b> RIDUTTORI A VITE SENZA FINE COMBINATI	<b>COMBINED WORM GEARBOXES</b>	<b>KOMBINIERT- SCHNECKENGETRIEB</b>	<b>E1</b>
	<b>XXC</b> RIDUTTORI A VITE SENZA FINE COMBINATI	<b>COMBINED WORM GEARBOXES</b>	<b>KOMBINIERT- SCHNECKENGETRIEB</b>	<b>E1</b>
	<b>VM</b> RIDUTTORI A VITE SENZA FINE DOPPIA USCITA	<b>DOUBLE OUTPUT WORM GEARBOXES</b>	<b>SCHNECKENGETRIEB MIT ZWEI AUSGANGSWELLEN</b>	<b>F1</b>
	<b>N</b> VARIATORI	<b>VARIATORS</b>	<b>VERSTELLGETRIEBE</b>	<b>G1</b>
	<b>UDL</b> VARIATORI	<b>VARIATORS</b>	<b>VERSTELLGETRIEBE</b>	<b>H1</b>
	<b>MOTORI ELETTRICI</b>	<b>ELECTRIC MOTORS</b>	<b>ELEKTROMOTOREN</b>	<b>I1</b>
	<b>CONDIZIONI GENERALI DI VENDITA</b>	<b>TERM AND CONDITIONS OF SALE</b>	<b>ALLGEMEINE VERKAUFSBEDINGUNGEN</b>	<b>L1</b>

**GENERALITA'**
**GENERAL INFORMATION**
**ALLGEMEINES**
**Unità di misura**
**Measurement units**
**Maßeinheiten**

Tab. 1

SIMBOLO SYMBOL SYMBOLE	DEFINIZIONE	DEFINITION	BEZEICHNUNG	UNITA' DI MISURA MEASUREMENT UNIT MAßEINHEIT
$F_{R 1-2}$	Carico Radiale	Radial load	Radialbelastung	N
$F_{A 1-2}$	Carico Assiale	Axial load	Axialbelastung	N
	Dimensioni	Dimensions	Abmessungen	mm
<b>FS</b>	Fattore di servizio	Service factor	Betriebsfaktor	
<b>kg</b>	Massa	Mass	Masse	kg
$T_{2M}$	Momento torcente riduttore	Gearbox torque	Getriebe Drehmoment	Nm
$T_2$	Momento torcente motorid.	Gearmotor torque	Getriebemotor Drehmoment	Nm
$M_{2S}$	Coppia di slittamento	Slipping torque	Rutschmoment	Nm
<b>P</b>	Potenza riduttore	Gearbox capacity	Getriebeleistung	kW
<b>Pc</b>	Potenza corretta	Corrected power	Verbesserte Leistung	kW
$P_1$	Potenza motoriduttore	Gearmotor power	Getriebemotor Leistung	kW
$P_2$	Potenza in uscita	Output power	Abtriebsleistung	kW
$P_{tc}$	Potenza termica corretta	Corrected thermal power	verbesserte thermische Leistung	kW
$P_{t0}$	Potenza termica	Thermal power	Thermische Leistung	kW
<b>P'</b>	Potenza richiesta in uscita	Output power	Erforderliche Abtriebsleistung	kW
<b>Rd</b>	Rendimento dinamico	Dynamic efficiency	dinamischer Wirkungsgrad	
<b>Rs</b>	Rendimento statico	Static efficiency	statischer Wirkungsgrad	
$i_1$	Rapp. di riduzione del 1° riduttore	Ratio of 1st gearbox	Untersetzungverhältnis des 1. Getriebes	
$i_2$	Rapp. di riduzione del 2° riduttore	Ratio of 2nd gearbox	Untersetzungverhältnis des 2. Getriebes	
$i_n$	Rapp. di riduzione	Reduction ratio	Untersetzungverhältnis	
$n_1$	Velocità albero entrata	Input speed	Antriebsdrehzahl	rpm
$n_2$	Velocità albero uscita	Output speed	Abtriebsdrehzahl	
<b>Ta</b>	Temperatura ambiente	Ambient temperature	Umgebungstemperatur	°C
$\eta$	Rendimento	Efficiency	Wirkungsgrad	
<b>IEC</b>	Motori accoppiabili	Motor options	Passende Motoren	

**Fattore di servizio**
**Service factor**
**Betriebsfaktor**

Il fattore di servizio FS permette di qualificare, in prima approssimazione, la tipologia dell'applicazione tenendo conto della natura del carico (A, B, C), della durata di funzionamento h/gg (ore giornaliere) e del numero di avviamenti/ora. Il coefficiente così trovato dovrà essere uguale o inferiore al fattore di servizio del riduttore FS' dato dal rapporto fra la coppia nominale del riduttore  $T_{2M}$  indicata a catalogo e la coppia  $T_2'$  richiesta dall'applicazione.

Service factor **FS** enables approximate qualification of the type of application, taking into account type of load (A,B,C), length of operation h/d (hours/day) and the number of starts-up/hour. The coefficient thus calculated must be equal to or lower than the gear unit service factor FS' which equals the ratio between  $T_{2M}$  (gear unit rated torque reported in the catalogue) and  $T_2'$  (torque required by the application).

Der FS Betriebsfaktor ermöglicht die annähernde Bestimmung der Anwendungsart. Dabei werden Art der Last (A, B, C), Betriebsstunden pro Tag (S/T) und Anzahl der Starts pro Stunde berücksichtigt. Der so ermittelte Koeffizient sollte dem Betriebsfaktor FS', der sich aus dem Verhältnis zwischen Nenndrehmoment des Getriebes  $T_{2M}$  (s. Katalog) und dem für die Anwendung erforderlichen Drehmoment  $T_2'$  ergibt, entweder entsprechen oder niedriger liegen.

$$FS' = \frac{T_{2M}}{T_2'} > FS$$

I valori di FS indicati nella tab. 2, sono relativi all'azionamento con motore elettrico; se utilizzato un motore a scoppio, si dovrà tenere conto di un fattore di moltiplicazione 1.3 se a più cilindri e 1.5 se monocilindro. Se il motore elettrico applicato è autofrenante, considerare un numero di avviamenti doppio di quello effettivamente richiesto.

FS values reported in table 2 refer to a drive unit equipped with an electric motor. If an internal combustion engine is used, a multiplication factor of 1.3 must be applied for a several-cylinder engine, 1.5 for a single-cylinder engine. If the electric motor is self-braking, consider twice the number of starts-up than those actually required.

Die FS Werte, die in Tabelle 2 angegeben werden, beziehen sich auf den Antrieb mit Elektromotor; falls ein Explosionsmotor verwendet wird, ist ein Multiplikationsfaktor von 1.3 für Mehrzylindermotor und von 1.5 für Einzylindermotor zu berücksichtigen. Falls der verwendete Elektromotor ein Bremsmotor ist, so ist die Zahl der tatsächlich erforderlichen Startvorgänge doppelt zu zählen.

Tab. 2

Classe di carico Load class Lastklasse	h/gg h/d St./Tag	N. AVVIAMENTI/ORA / N. START-UP/HOUR / ANZAHL DER STARTVORGÄNGE PRO STUNDE								
		2	4	8	16	32	63	125	250	500
<b>A</b>	4	0.8	0.8	0.9	0.9	1.0	1.1	1.1	1.2	1.2
	8	1.0	1.0	1.1	1.1	1.3	1.3	1.3	1.3	1.3
	16	1.3	1.3	1.3	1.3	1.5	1.5	1.5	1.5	1.5
	24	1.5	1.5	1.5	1.5	1.8	1.8	1.8	1.8	1.8
APPLICAZIONI / APPLICATIONS / ANWENDUNGEN										
Agitatori per liquidi puri <i>Pure liquid agitators</i> Rührwerke für reine Flüssigkeiten Alimentatori per fornaci <i>Furnace feeders</i> Beschickungsvorrichtungen für Brennöfen Alimentatori a disco <i>Disc feeders</i> Telleraufgeber Filtri di lavaggio con aria <i>Air laundry filters</i> Spülluftfilter Generatori <i>Generators</i> Generatoren Pompe centrifughe <i>Centrifugal pumps</i> Kreiselpumpen Trasportatori con carico uniforme <i>Uniform load conveyors</i> Förderer mit gleichmäßig verteilter Last										

Classe di carico Load class Lastklasse	h/gg h/d St./Tag	N. AVVIAMENTI/ORA / N. START-UP/HOUR / ANZAHL DER STARTVORGÄNGE PRO STUNDE								
		2	4	8	16	32	63	125	250	500
<b>B</b>	4	1.0	1.0	1.0	1.0	1.3	1.3	1.3	1.3	1.3
	8	1.3	1.3	1.3	1.3	1.5	1.5	1.5	1.5	1.5
	16	1.5	1.5	1.5	1.5	1.8	1.8	1.8	1.8	1.8
	24	1.8	1.8	1.8	1.8	2.2	2.2	2.2	2.2	2.2
APPLICAZIONI / APPLICATIONS / ANWENDUNGEN										
Agitatori per liquidi e solidi <i>Liquid and solid agitators</i> Rührwerke für Flüssigkeiten und Feststoffe Alimentatori a nastro <i>Belt conveyors</i> Bandförderer Argani con medio servizio <i>Medium service winches</i> Mittlere Winden Filtri con pietre e ghiaia <i>Stone and gravel filters</i> Filter mit Steinen/Kies Viti per espulsione acqua <i>Dewatering screws</i> Abwasserschnecken Flocculatori <i>Flocculator</i> Flockvorrichtungen Filtri a vuoto <i>Vacuum filters</i> Vakuumfilter Elevatori a tazze <i>Bucket elevators</i> Becherwerke Gru <i>Cranes</i> Kräne										

Classe di carico Load class Lastklasse	h/gg h/d St./Tag	N. AVVIAMENTI/ORA / N. START-UP/HOUR / ANZAHL DER STARTVORGÄNGE PRO STUNDE								
		2	4	8	16	32	63	125	250	500
<b>C</b>	4	1.3	1.3	1.3	1.3	1.5	1.5	1.5	1.5	1.5
	8	1.5	1.5	1.5	1.5	1.8	1.8	1.8	1.8	1.8
	16	1.8	1.8	1.8	1.8	2.2	2.2	2.2	2.2	2.2
	24	2.2	2.2	2.2	2.2	2.5	2.5	2.5	2.5	2.5
APPLICAZIONI / APPLICATIONS / ANWENDUNGEN										
Argani per servizio pesante <i>Heavy duty hoists</i> Winden für schwere Lasten Estrusori <i>Extruders</i> Extruder Calandre per gomma <i>Crusher rubber calenders</i> Gummikalander Presse per mattoni <i>Brick presses</i> Ziegelpressen Pialatrici <i>Planing machine</i> Hobelmaschinen Mulini a sfera <i>Ball mills</i> Kugelmühle										

## Potenza

$P$  = Potenza massima applicabile in entrata con vite ad albero maschio riferita alla velocità  $n_1$  con un fattore di servizio  $FS = 1$  e a un servizio continuo S1.

$P_1$  = Potenza motore consigliata riferita alla velocità  $n_1$  con il fattore di servizio  $FS$  riportato in tabella a pag. A7 e a servizio continuo S1.

È possibile determinare la potenza necessaria in entrata  $P'$  in base alla coppia  $T_2'$  richiesta all'applicazione secondo la seguente formula:

## Power

$P$  = max. power applicable at input with male worm shaft, referred to  $n_1$  speed, service factor  $FS=1$ , on S1 continuous duty.

$P_1$  = recommended motor power, referred to  $n_1$  speed, service factor  $FS$  as reported in the table on page A7, on S1 continuous duty.

The necessary input power with regard to  $T_2'$  torque required by the application, is to be calculated with the following formula:

## Leistung

$P$  = am Antrieb max. anwendbare Leistung, mit Schneckenwellenzapfen bez.  $n_1$  Antriebsdrehzahl, Betriebsfaktor  $FS=1$  und S1 Dauerbetrieb.

$P_1$  = beratene Motorleistung bez.  $n_1$  Drehzahl,  $FS$  Betriebsfaktor (wie es in der Tabelle auf Seite A7 angegeben wird) und S1 Dauerbetrieb.

Die am Antrieb erforderliche Leistung  $P'$  (auf Grund des von der Anwendung verlangten  $T_2'$  Drehmoments) kann wie folgt kalkuliert werden:

$$P' = \frac{T_2' \cdot n_2}{9550 \cdot Rd} \quad [\text{kW}]$$

## Rapporto di riduzione

$i_n$  = È il rapporto di riduzione della velocità, definito come:

## Reduction Ratio

$i_n$  = speed reduction ratio, defined as follows:

## Untersetzungsverhältnis

$i_n$  = Drehzahluntersetzungsverhältnis, wird wie folgt definiert:

$$i_n = \frac{n_1}{n_2}$$

## Momento torcente

$T_{2M}$  = È la massima coppia trasmissibile in uscita del riduttore con carico uniforme riferito alla velocità  $n_1$  con un fattore di servizio  $FS = 1$  e a servizio continuo S1.

$T_2$  = È la coppia in uscita del motoriduttore riferita alla velocità  $n_1$  alla potenza  $P_1$ , con il fattore di servizio  $FS$  riportato in tabella e a servizio continuo S1.

## Torque

$T_{2M}$  = max. torque transmissible at gearbox output with uniform load, referred to  $n_1$  speed, service factor  $FS = 1$ , on S1 continuous duty.

$T_2$  = output torque transmissible to the geared motor, referred to  $n_1$  speed,  $P_1$  power,  $FS$  service factor as reported in the table, on S1 continuous duty.

## Drehmoment

$T_{2M}$  = am Getriebeabtrieb max. übertragbaren Drehmoment, bei gleichmäßiger Last bez.  $n_1$  Drehzahl, Betriebsfaktor  $FS = 1$  und S1 Dauerbetrieb.

$T_2$  = übertragbares Abtriebsdrehmoment, bezogen auf die Antriebsdrehzahl  $n_1$ , die Leistung  $P_1$  und dem in der Tabelle angegebenen Betriebsfaktor  $FS$  bei Dauerbetrieb S1.

$$T_{2M} = \frac{9550 \cdot P_1 \cdot Rd}{n_2} \quad [\text{Nm}]$$

## Rendimento

**Rd** - È il rendimento dinamico, definito come rapporto tra la potenza in uscita  $P_2$  e quella in entrata  $P_1$ . Dipende principalmente dalla velocità di strisciamento, dal tipo di lubrificante e dall'angolo d'elica. I valori indicati nelle tabelle sono validi se si applica la corrispondente coppia in uscita. In fase di rodaggio, circa le prime 300 ore di funzionamento sotto carico, il valore deve essere considerato inferiore del 30% rispetto a quello indicato in tabella.

**Rs** - È il rendimento statico che si ha al momento dell'avviamento del riduttore e varia in base al rapporto di riduzione. Risulta importante, per una corretta valutazione del riduttore da impiegare, nelle applicazioni in cui non si raggiungono mai le condizioni di regime come nei funzionamenti intermittenti. Analogamente al caso dinamico, anche il rendimento statico durante il rodaggio risulta inferiore del 30% rispetto al valore indicato in tabella.

## Efficiency

**Rd** - dynamic efficiency, defined as the ratio between  $P_2$  output power and  $P_1$  input power. It mainly depends on the slipping speed, the type of lubricant and the lead angle. The values reported in the table are valid when the corresponding output torque is applied. During the first 300 operating hours under load, the value to be considered is 30% lower than that reported in the table.

**Rs** - static efficiency at gearbox start-up; it changes depending on the reduction ratio. *Rs* value is important for selecting the right gearbox for applications where a steady state is never achieved, as for intermittent duty applications. Same as dynamic efficiency, static efficiency too during the running-in period will be 30% lower than the value reported in the table.

## Wirkungsgrad

**Rd** - dynamischer Wirkungsgrad, ist das Verhältnis zwischen  $P_2$  Abtriebsleistung und  $P_1$  Antriebsleistung. Rd Wert wird durch Gleitgeschwindigkeit, Art des Schmiermittels und Steigungswinkel beeinflusst. Die Tabellen zeigen die Werte die gültig sind wenn das entsprechende Abtriebsdrehmoment gegeben ist. Während der Einlaufzeit in den ersten 300 Betriebsstunden unter Belastung, ist dieser Wert 30% niedriger als der in der Leistungstabelle angegebenen Wert.

**Rs** - statischer Wirkungsgrad beim Getriebestart und in Abhängigkeit zur Untersetzung. Der Wert  $R_s$  ist wichtig für die Auswahl des richtigen Getriebes für Anwendungen wo ein stetiger Betrieb nicht auftritt, wie bei Anwendungen mit Aussetzbetrieb. Der statischer Wirkungsgrad auch während der Einlaufzeit wird 30% niedriger als der in der Tabelle angegebenen Wert.

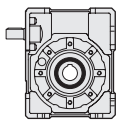

X - K	Rs											
	5	7.5	10	15	20	25	30	40	50	65	80	100
30	0.70	0.67	0.62	0.55	0.47	0.43	0.39	0.30	0.27	0.25	0.22	0.21
40	0.69	0.67	0.63	0.55	0.52	0.45	0.40	0.35	0.29	0.26	0.25	0.23
50	0.69	0.68	0.65	0.58	0.53	0.47	0.41	0.37	0.32	0.28	0.25	0.23
63	0.70	0.68	0.65	0.57	0.55	0.50	0.47	0.38	0.33	0.29	0.28	0.23
75	/	0.68	0.65	0.58	0.55	0.51	0.43	0.39	0.35	0.31	0.28	0.24
89	/	0.68	0.65	0.58	0.55	0.52	0.45	0.39	0.36	0.32	0.29	0.25
90	/	0.68	0.65	0.58	0.55	0.52	0.45	0.39	0.36	0.32	0.29	0.25
110	/	0.68	0.66	0.59	0.56	0.53	0.44	0.40	0.38	0.33	0.30	0.26
130	/	0.69	0.66	0.60	0.57	0.55	0.44	0.42	0.39	0.35	0.32	0.28

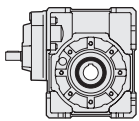

H	Rs										
	30	40	60	80	100	120	160	200	260	320	400
40	0.66	0.62	0.54	0.51	0.44	0.39	0.34	0.28	0.25	0.24	0.22
50	0.66	0.64	0.57	0.52	0.46	0.40	0.36	0.31	0.27	0.24	0.22
63	0.67	0.64	0.56	0.54	0.49	0.46	0.37	0.32	0.28	0.27	0.22
75	0.67	0.64	0.57	0.54	0.50	0.42	0.38	0.34	0.30	0.27	0.23
90	0.67	0.64	0.57	0.54	0.51	0.44	0.38	0.35	0.31	0.28	0.24
110	0.67	0.65	0.58	0.55	0.52	0.43	0.39	0.37	0.32	0.30	0.25
130	0.68	0.65	0.59	0.56	0.54	0.43	0.41	0.38	0.34	0.31	0.27

Stabilito il rapporto di riduzione necessario all'applicazione, dove è possibile, è consigliabile utilizzare i diversi tipi di riduttori che offrono, a parità di rapporto, un migliore rendimento dinamico.

Once the reduction ratio required by the application has been established, it is advisable to select a type of gearbox which, ratio being equal, offers better dynamic efficiency.

Nachdem das für die Anwendung erforderliche Untersetzungsverhältnis festgestellt worden ist, wählen Sie bei gleichem Untersetzungsverhältnis einen Getriebetyp, den einen besseren dynamischen Wirkungsgrad aufweist.

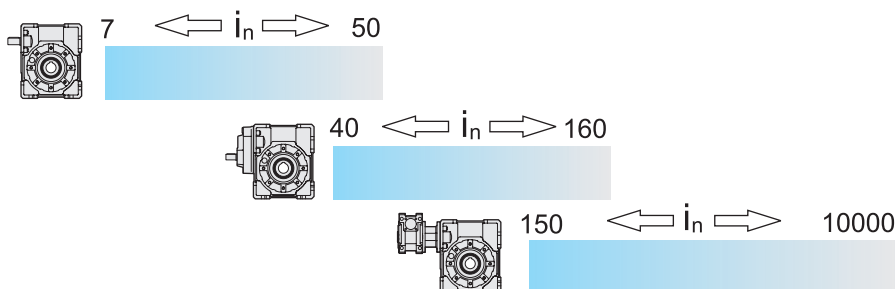

## Irreversibilità

Nelle applicazioni dove è necessario evitare la trasmissione del moto retrogrado o sostenere il carico, in assenza di alimentazione elettrica, è consigliabile adottare freni esterni. Nei riduttori a vite senza fine emerge questa caratteristica naturale, denominata grado di irreversibilità, che cresce con l'aumentare del rapporto di riduzione in quanto strettamente legata al relativo rendimento.

Per ottenere alti gradi di irreversibilità occorre quindi adottare i rapporti di riduzione più elevati, senza dimenticare che, il rendimento, tende a crescere durante le prime 500 ore di funzionamento per poi stabilizzarsi sui valori riportati a catalogo.

### Irreversibilità statica

Condizione di impedimento alla rotazione comandata dall'albero lento senza escludere possibili ritorni lenti nel caso in cui il carico sia sottoposto a vibrazioni.

**Rs < 0.45** si ha irreversibilità  
**Rs = 0.45 ÷ 0.55** irreversibilità incerta  
**Rs > 0.55** si ha reversibilità

### Irreversibilità dinamica

Condizione di arresto e quindi di sostegno del carico nel momento in cui cessa l'azione di comando. La condizione è più difficile da ottenere in quanto viene influenzata dal rendimento dinamico, dalla velocità di rotazione, da eventuali vibrazioni che il carico può generare e dalla direzione del movimento rispetto al carico.

Quest'ultima condizione è molto evidente nei sollevamenti: un carico in salita, cessando l'azione di comando, deve arrestarsi e quindi assumere velocità zero (rendimento statico) prima di invertire il moto e cadere per gravità.

Un carico in discesa tende invece a proseguire nel suo moto ostacolato, nella caduta, dal solo rendimento dinamico.

**Rd < 0.45** si ha irreversibilità  
**Rd = 0.45 ÷ 0.55** irreversibilità incerta  
**Rd > 0.55** si ha reversibilità

## Irreversibility

*The use of external brakes is advised in case of applications where backwards motion must be hindered and the load must be held should the feed be cut off.*

*Some worm gearboxes feature natural irreversibility. The higher the ratio, the higher is the irreversibility, since it is strictly dependent on the relative efficiency.*

*In order to achieve high irreversibility it is therefore necessary to select higher efficiency reduction ratios not to forget that the efficiency is growing during the first 500 hours life until it stabilizes to the values mentioned in the catalogue.*

### Static irreversibility

*Static irreversibility occurs when the rotation controlled by the output shaft is hindered; possible slow returns cannot be excluded should the load be subject to vibrations.*

**Rs < 0.45** provides irreversibility  
**Rs = 0.45 ÷ 0.55** irreversibility is uncertain  
**Rs > 0.55** reversibility is possible

### Dynamic irreversibility

*Dynamic irreversibility is characterized by stillstand and hold of the load when the drive stops. It is more difficult to achieve this condition because it is influenced by dynamic efficiency, speed of rotation and possible vibrations generated by the motion direction with regard to the load.*

*This last condition is much more evident during the lifting: if the drive stops during the lifting of the load this has to come to a speed equals to zero (static irreversibility) before the reversal of motion rotation and its drop for gravity.*

*On the contrary the load during its descent gets its motion obstructed by its dynamic efficiency.*

**Rd < 0.45** provides irreversibility  
**Rd = 0.45 ÷ 0.55** irreversibility is uncertain  
**Rd > 0.55** reversibility is possible

## Selbsthemmung

Aussenbremsen sind bei Anwendungen zu benutzen, bei denen Rückbewegung vermeiden werden muss oder die Last auch im Falle von Fehlen an Speisung gehalten werden muss.

Einige Schneckengetriebe sind selbsthemmend. Je höher die Untersetzung ist, desto höher ist die Selbsthemmung, da diese stark vom jeweiligen Wirkungsgrad abhängig ist. Um eine höhere Selbsthemmung zu erreichen, wählen Sie bitte höhere Untersetzungsverhältnisse. Bitte beachten Sie, dass der Wirkungsgrad der Getriebe in den ersten 500 Betriebsstunden ansteigt und sich erst anschließend auf die im Katalog angegebenen Werte stabilisiert.

### Statische Selbsthemmung

Statische Selbsthemmung liegt vor, wenn die von Abtriebswelle gesteuerten Drehung gehindert wird. Langsamer Rücklauf ist möglich, falls die Last Schwingungen ausgesetzt wird.

**Rs < 0.45** es liegt Selbsthemmung vor  
**Rs = 0.45 ÷ 0.55** ungewisse Selbsthemmung  
**Rs > 0.55** es liegt Reversibilität vor

### Dynamische Selbsthemmung

Stillstand und Stütze der Last beim Aussetzen der Steuerung. Diese Bedingung ist schwieriger zu erreichen, da sie vom dynamischen Wirkungsgrad, der Drehzahl und von der Last verursachten möglichen Vibrationen abhängig ist

Dieser letzte Fall kommt bei Hubanwendungen stark zu tragen. Wenn der Antrieb während dem Hub stoppt, muss die Last eine Geschwindigkeit von annähernd null erreichen (statische Irreversibilität), bevor die Rotation sich umkehrt und die Last durch die Gravitation nach unten fährt. Dem entgegengesetzt bekommt die Last durch die Abwärtsbewegung Ihre dynamische Effizienz.

**Rd < 0.45** es liegt Selbsthemmung vor  
**Rd = 0.45 ÷ 0.55** ungewisse Selbsthemmung  
**Rd > 0.55** es liegt Reversibilität vor

## Gioco angolare

## Backlash

## Winkelspiel

### Gioco angolare standard

### Standard Backlash

### Standardmäßiges Winkelspiel

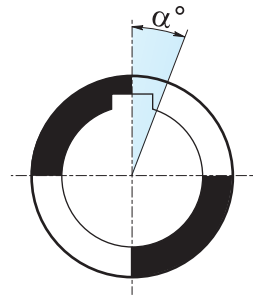

X - K									
$i_n$	30	40	50	63	75	89	90	110	130
	max	max	max	max	max	max	max	max	max
5	16'	13.5'	10.5'	10'	/	/	/	/	/
7.5	16'	13.5'	10.5'	10'	10'	9.5'	9.5'	8'	8'
10	16'	13.5'	10.5'	10'	10'	9'	9'	8'	8'
15	16'	13.5'	10.5'	10'	10'	9'	9'	8'	8'
20	14.5'	12'	9.5'	8.5'	8.5'	8.5'	8.5'	7'	8'
25	14.5'	12'	9.5'	8.5'	8.5'	8.5'	8.5'	7'	7'
30	14.5'	12'	8.5'	8.5'	8.5'	8.5'	8.5'	7'	7'
40	14.5'	12'	9.5'	8.5'	8.5'	8'	8'	7'	7'
50	14'	12'	9.5'	8.5'	8.5'	8'	8'	7'	7'
65	14'	12'	9'	8'	8'	8'	8'	7'	7'
80	13.5'	11.5'	9'	7.5'	7.5'	7.5'	7.5'	7'	7'
100	13'	11'	9'	7.5'	7.5'	7.5'	7.5'	7'	7'

H								
$i_n$	40	50	63	75	90	110	130	
	max	max	max	max	max	max	max	max
30	16.5'	13.5'	12'	12'	11.5'	9'	9'	9'
40	16.5'	13.5'	12'	12'	11'	9'	9'	9'
60	16.5'	13.5'	12'	12'	11'	9'	9'	9'
80	15'	12.5'	10.5'	10.5'	10.5'	8'	8'	8'
100	15'	12.5'	10.5'	10.5'	10.5'	8'	8'	8'
120	16.5'	14.5'	11.5'	12'	11'	9'	8'	8'
160	15'	12.5'	10.5'	10.5'	10.5'	8'	8'	8'
200	15'	12.5'	10.5'	10.5'	10'	8'	8'	8'
260	15'	12.5'	10.5'	10.5'	10'	8'	8'	8'
320	14.5'	12'	9.5'	9.5'	9.5'	8'	8'	8'
400	14'	12'	9.5'	9.5'	9.5'	8'	8'	8'

Misurato bloccando l'albero entrata, e ruotando l'albero uscita nelle due direzioni applicando la coppia strettamente necessaria a creare il contatto tra i denti degli ingranaggi, al massimo pari al 2% della coppia nominale ( $T_{2M}$ ).

*Angular backlash measured after having blocked the input shaft by rotating output shaft in both directions and applying the torque which is strictly necessary to create a contact between the teeth of the gears. The applied torque should be at most 2% of the max. torque ( $T_{2M}$ ).*

Nachdem die Antriebswelle blockiert worden ist, darf das Winkelspiel auf die Abtriebswelle bemessen werden. Dabei soll die Antriebswelle in beiden Richtungen gedreht werden und ein Drehmoment ausgeübt werden, das zur Entstehen eines Kontaktes zwischen den Zähnen genuegt. Das ausgeübte Drehmoment soll höchstens 2% des max. von Getrieben garantierten Drehmoment ( $T_{2M}$ ) sein.

### Gioco angolare ridotto

I giochi angolari ridotti esposti in tabella si possono ottenere solo costruendo corone speciali. Da notare che l'usura dovuta al funzionamento rende la versione con gioco ridotto di durata limitata direttamente proporzionale al fattore di servizio (fs) dell'applicazione: più il riduttore è sovradimensionato e maggiore è la durata del gioco ridotto.

### Reduced Backlash

The reduced angular clearance shown in the table can only be obtained by building special crowns. It must be noted that the wear due to operation makes the version with reduced clearance of limited duration directly proportional to the service factor (fs) of the application: the more oversized the reducer, the longer the duration of the reduced backlash.

### Reduziertes Winkelspiel

Die in der Tabelle angegebenen reduzierten Winkelspiele können nur erzielt werden, wenn spezielle Kränze hergestellt werden. Es muss hervorgehoben werden, dass der durch den Betrieb bewirkte Verschleiß bei der Version mit reduziertem Spiel eine zum Betriebsfaktor (fs) der Anwendung direkt proportionale Dauer aufweist: Je größer das Getriebe ist, desto länger dauert das reduzierte Spiel.

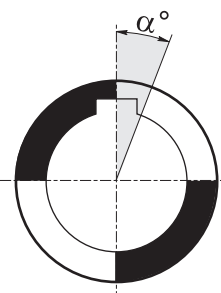

X - K									
$i_n$	30	40	50	63	75	89	90	110	130
	max	max	max	max	max	max	max	max	max
5 ÷ 100	7'	6'	5'	5'	4'	4'	4'	4'	4'

  

H								
$i_n$	40	50	63	75	90	110	130	
	max	max	max	max	max	max	max	max
5 ÷ 100	8'	7'	7'	6'	6'	6'	6'	6'

**Senso di rotazione**

**Direction of rotation**

**Drehrichtung**

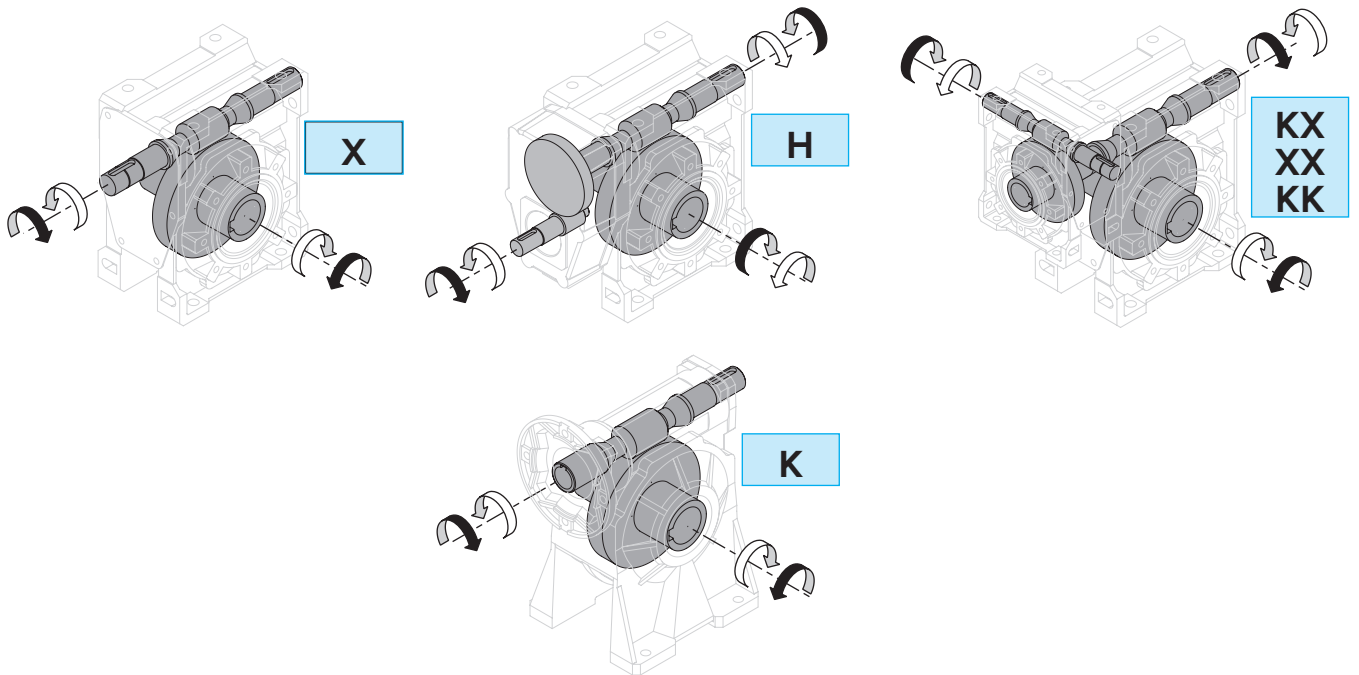

**Carichi radiali**

**Radial load**

**Radialbelastungen**

Ogni tipo di organo di trasmissione che viene collegato o sull'albero in entrata o in quello di uscita determina carichi radiali rispettivamente  $F_{R1}$  e  $F_{R2}$ . I valori riportati in tabella in funzione delle varie velocità in entrata e in uscita sono da considerarsi applicabili come forza agente a metà della sporgenza; per un posizionamento a 1/3 della lunghezza occorre aumentare i valori di tabella del 25% mentre per un posizionamento a 2/3 della lunghezza occorre diminuire gli stessi valori del 25%. I valori dei carichi assiali applicabili in entrata  $F_{A1}$  e in uscita  $F_{A2}$  sono indicati nelle tabelle. Negli alberi bisporgenti, ogni estremità può sopportare un carico radiale pari ai 3/5 dei valori riportati in tabella purché agiscano nello stesso senso e siano di pari intensità

Any transmission device coupled to either the input or to the output shaft generates radial loads,  $F_{R1}$  and  $F_{R2}$  respectively. The load values reported in the table, depending on input and output speed, are to be considered as acting at the half-way point of the projection; if the load is applied at 1/3 of the projection, increase the values in the table by 25%; if the load is applied at 2/3, reduce the values by 25%. Axial loads applicable at input  $F_{A1}$  and at output  $F_{A2}$  are reported in the tables. With regard to double projecting shafts, each end can sustain a radial load which equals 3/5 of the values listed in the table, on condition that they act in the same direction and have the same intensity.

Antriebsorgane, die mit der Antriebs- oder Abtriebswelle verbindet werden, bewirken Radialbelastungen ( $F_{R1}$  und  $F_{R2}$  beziehungsweise). Die in der Tabelle nach Antriebs- und Abtriebsdrehzahl angegebenen Werte beziehen sich auf Belastungen, die in der Mitte der herausragenden Welle wirken; falls die Belastungen auf 1/3 der Länge wirken, sollen die in der Tabelle angegebenen Werte um 25% erhöht werden; falls sie auf 2/3 der Länge wirken, sollen die Werte der Tabelle um 25% reduziert werden. Die Werte der anwendbaren Axialbelastungen ( $F_{A1}$  am Antrieb und  $F_{A2}$  am Abtrieb) werden in den Tabellen angegeben. Bei doppelseitig herausragenden Wellen darf die Radialbelastung auf jedes Ende 3/5 der nachstehenden Werte betragen, unter die Bedingung dass Stärke und Richtung gleich sind.

**Carichi radiali  $F_{R1}$  e assiali  $F_{A1}$  sull'albero entrata [N]**

**$F_{R1}$  radial loads and  $F_{A1}$  axial loads on the input shaft [N]**

**$F_{R1}$  Radialbelastungen und  $F_{A1}$  Axialbelastungen auf die Antriebswelle [N]**

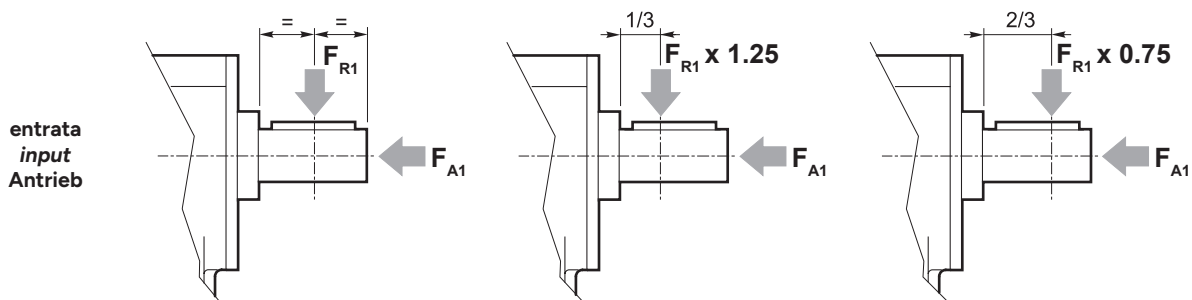

Introduzione | Introduction | Einführung

**Carichi radiali**

**Radial load**

**Radialbelastungen**

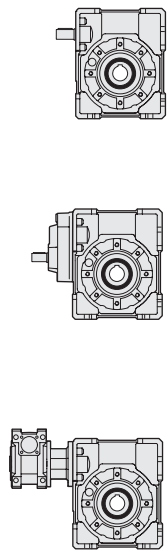

n <sub>1</sub> [rpm]	XA30		XA40		XA50		XA63		XA75		XA90		XA110		XA130		
	F <sub>R1</sub>	F <sub>A1</sub>	F <sub>R1</sub>	F <sub>A1</sub>	F <sub>R1</sub>	F <sub>A1</sub>	F <sub>R1</sub>	F <sub>A1</sub>	F <sub>R1</sub>	F <sub>A1</sub>	F <sub>R1</sub>	F <sub>A1</sub>	F <sub>R1</sub>	F <sub>A1</sub>	F <sub>R1</sub>	F <sub>A1</sub>	
1400	100	20	220	44	400	80	480	96	750	150	850	170	1200	240	1500	300	
1400			HA40		HA50		HA63		HA75		HA90		HA110		HA130		
			F <sub>R1</sub>	F <sub>A1</sub>	F <sub>R1</sub>	F <sub>A1</sub>	F <sub>R1</sub>	F <sub>A1</sub>	F <sub>R1</sub>	F <sub>A1</sub>	F <sub>R1</sub>	F <sub>A1</sub>	F <sub>R1</sub>	F <sub>A1</sub>	F <sub>R1</sub>	F <sub>A1</sub>	
				150	30	250	50	320	64	570	114	570	114	800	160	1000	200
1400	XXA30/30 XXA30/40 XXA30/50 XXA30/63		XXA40/63 XXA40/75 XXA40/89 XXA40/90		XXA50/75 XXA50/89 XXA50/90 XXA50/110		XXA63/110		XXA63/130								
	F <sub>R1</sub>	F <sub>A1</sub>	F <sub>R1</sub>	F <sub>A1</sub>	F <sub>R1</sub>	F <sub>A1</sub>	F <sub>R1</sub>	F <sub>A1</sub>	F <sub>R1</sub>	F <sub>A1</sub>							
	100	20	220	44	400	80	480	96	480	96							

Carichi radiali F<sub>R2</sub> e assiali F<sub>A2</sub> sull'albero uscita [N]

F<sub>R2</sub> radial loads and F<sub>A2</sub> axial loads on the output shaft [N]

F<sub>R2</sub> Radialbelastungen und F<sub>A2</sub> Axialbelastungen auf die Abtriebswelle [N]

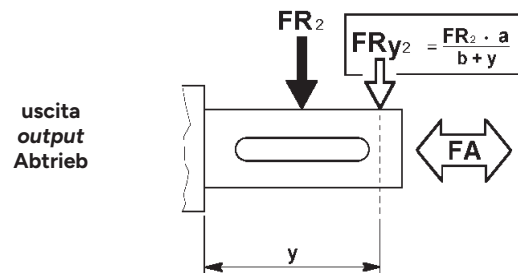

CUSCINETTI RADIALI A SFERE / RADIAL BALL BEARINGS / SCHRÄGKUGELLAGER																			
n <sub>1</sub> =1400 rpm	30		40		50		63		75		89		90		110		130		
	30/30		30/40		30/50		30/63 40/63		40/75 50/75		40/89 50/89		40/90 50/90		50/110 63/110		63/130		
i <sub>n</sub>	n <sub>2</sub> [rpm]	a = 66.5	b = 49	a = 83.5	b = 60.5	a = 102	b = 73.5	a = 122.5	b = 93.5	a = 134	b = 100	a = 163	b = 118	a = 163	b = 118	a = 179.5	b = 131.5	a = 190	b = 145
		F <sub>R2</sub>	F <sub>A2</sub>	F <sub>R2</sub>	F <sub>A2</sub>	F <sub>R2</sub>	F <sub>A2</sub>	F <sub>R2</sub>	F <sub>A2</sub>	F <sub>R2</sub>	F <sub>A2</sub>	F <sub>R2</sub>	F <sub>A2</sub>	F <sub>R2</sub>	F <sub>A2</sub>	F <sub>R2</sub>	F <sub>A2</sub>	F <sub>R2</sub>	F <sub>A2</sub>
5	280	700	140	1400	280	1400	300	1800	360	/	/	/	/	/	/	/	/	/	/
7.5	187	750	150	1500	300	1650	330	2100	420	2500	500	2600	520	2600	520	3500	700	5100	1020
10	140	800	160	1600	320	1800	360	2300	460	2800	560	3000	600	3000	600	3800	760	5600	1120
15	93	850	170	1700	340	1950	390	2600	520	3000	600	3400	680	3400	680	4200	840	6400	1280
20	70	900	180	1800	360	2200	440	2800	560	3300	660	3800	760	3800	760	4600	920	7000	1400
25	56	950	190	1900	380	2400	480	3100	620	3700	740	4100	820	4100	820	5100	1020	7600	1520
30	47	1000	200	2000	400	2600	520	3400	680	4000	800	4500	900	4500	900	5600	1120	8050	1610
40	35	1050	210	2100	420	2850	570	3700	740	4400	880	4900	980	4900	980	6100	1220	8800	1760
50	28	1100	220	2200	440	3100	620	4000	800	4850	970	5300	1060	5300	1060	6700	1340	9500	1900
60	23	1150	230	2400	480	3200	640	4200	840	5000	1000	5600	1120	5600	1120	7100	1420	9800	2000
63	22	1250	250	2500	500	3400	680	4450	890	5300	1060	5900	1180	5900	1180	7400	1480	10100	2020
80	17.5	1350	270	2700	540	3800	760	4900	980	5800	1160	6500	1300	6500	1300	8100	1620	11200	2240
100	14	1500	300	3000	600	4000	800	5400	1080	6500	1300	7000	1400	7000	1400	8500	1700	12050	2410
120	11.7	1520	304	3100	620	4100	820	5500	1100	6550	1310	7100	1420	7100	1420	8800	1760	12200	2500
150	9.3	1550	310	3150	630	4250	850	5600	1120	6600	1320	7300	1460	7300	1460	9100	1820	12500	2600
160	8.8	1570	314	3200	640	4300	860	5700	1140	6700	1340	7400	1480	7400	1480	9200	1840	12800	2650
≥ 200	≤ 7.0	1600	320	3300	660	4500	900	6000	1200	7100	1420	7900	1580	7900	1580	10000	2000	13000	2800

### Versioni rinforzate

A richiesta vengono fornite versioni rinforzate con cuscinetti a rulli conici sulla corona in grado di sopportare carichi superiori rispetto a quelli ammessi nelle versioni normali con cuscinetti radiali a sfere.

Essendo tali valori calcolati in funzione della durata dei cuscinetti, occorre valutare attentamente il tipo di versione più idoneo in modo da evitare problemi di tipo strutturale. In particolare, il carico assiale deve agire in modo da comprimere la flangia uscita.

**I carichi assiali e radiali riportati in tabella non possono agire contemporaneamente nei loro valori massimi.**

Nel caso di eventuale concorrenza delle due forze, queste devono essere limitate in rapporto al tipo di carico prevalente:

#### 1. condizione di prevalenza del carico radiale:

$$F_{R2} = \text{come a tabella}$$

$$F_{A2} = F_{R2} \cdot 0.37$$

#### 2. condizione di prevalenza del carico assiale:

$$F_{A2}' = F_{A2} \cdot 0.6$$

$$F_{R2}' = F_{A2} \cdot 0.4$$

### Reinforced versions

The versions reinforced with tapered roller bearings on the worm wheel are available on request. They can bear higher loads compared to standard versions with radial ball bearings.

These values are calculated in relation of the life of bearings therefore it is necessary to select the most suitable version in order to avoid any structural problem.

In particular the axial load must compress the output flange.

**The axial and radial loads shown in the table do not have to act simultaneously according to the max. values.**

In case of concurrency of both forces these have to be reduced with regard to the prevailing type of load:

#### 1. prevalence of radial load:

$$F_{R2} = \text{as per table}$$

$$F_{A2} = F_{R2} \cdot 0.37$$

#### 2. prevalence of axial load:

$$F_{A2}' = F_{A2} \cdot 0.6$$

$$F_{R2}' = F_{A2} \cdot 0.4$$

### Versionen mit Kegelrollenlager

Auf Wunsch können Versionen mit Kegelrollenlager auf dem Schneckenrad geliefert werden. Sie erlauben höheren Lasten in Vergleich zu den Standardprodukten mit Schrägkugellagern.

Diese Werte sind entsprechend der Lebensdauer der Lager berechnet. Daher ist es erforderlich, die am besten passende Ausführung zu wählen, um Probleme zu vermeiden. Auf alle Fälle muss die Axialbelastung den Abtriebsflansch zusammendrücken.

**Die in der Tabelle angegebenen Maximalwerte der Axial - und Radialbelastung sollten nicht gleichzeitig auftreten.**

Falls Axial-und Radialbelastungen auftreten, sollte jene Belastungsrichtung zur Auswahl herangezogen werden, die vom Anteil überwiegt:

#### 1. radialbelastungen überwiegen:

$$F_{R2} = \text{siehe Tabelle}$$

$$F_{A2} = F_{R2} \cdot 0.37$$

#### 2. Axialbelastungen überwiegen

$$F_{A2}' = F_{A2} \cdot 0.6$$

$$F_{R2}' = F_{A2} \cdot 0.4$$

CUSCINETTI A RULLI CONICI / TAPERED ROLLER BEARINGS / KEGELROLLENLAGER

n <sub>1</sub> =1400 rpm		30		40		50		63		75		89		90		110		130	
		30/30		30/40		30/50		30/63 40/63		40/75 50/75		40/89 50/89		40/90 50/90		50/110 63/110		63/130	
i <sub>n</sub>	n <sub>2</sub> [rpm]	a=61.4	b=43.9	a=77	b=54	a=94.5	b=66	a=114.8	b=85.8	a=123.8	b=89.8	a=152.8	b=107.8	a = 152.8	b = 107.8	a=167.3	b=119.3	a=174.8	b=129.8
		F <sub>R2</sub>	F <sub>A2</sub>	F <sub>R2</sub>	F <sub>A2</sub>	F <sub>R2</sub>	F <sub>A2</sub>	F <sub>R2</sub>	F <sub>A2</sub>	F <sub>R2</sub>	F <sub>A2</sub>	F <sub>R2</sub>	F <sub>A2</sub>	F <sub>R2</sub>	F <sub>A2</sub>	F <sub>R2</sub>	F <sub>A2</sub>	F <sub>R2</sub>	F <sub>A2</sub>
5	280	800	1100	1800	2300	4000	5000	4000	5000	/	/	/	/	/	/	/	/	/	/
7.5	187	900	1200	1900	2400	4500	5500	4500	5500	5300	6500	6000	8000	6000	8000	8000	10500	9500	11000
10	140	1000	1300	2000	2500	5000	6000	5000	6000	5500	6700	7000	9200	7000	9200	8300	11000	10500	12500
15	93	1100	1400	2100	2600	5800	7000	5800	7000	5700	6900	7400	9800	7400	9800	8800	11500	11000	13000
20	70	1250	1650	2300	2800	6000	7200	6100	7300	6400	7600	7800	10300	7800	10300	9300	12000	15000	13500
25	56	1450	1900	2500	3000	6200	7500	6500	7700	7400	9400	8500	11000	8500	11000	9800	12500	12000	14000
30	47	1700	2200	2800	3300	6500	7800	6800	8000	8000	10000	9500	12000	9500	12000	10500	13200	12500	14000
40	35	1800	2300	3000	3500	6600	8000	7000	8200	8500	10500	10000	12500	10000	12500	11000	14000	14000	16000
50	28	1900	2400	3200	3700	6800	8200	7100	8400	9000	11000	10500	13000	10500	13000	12000	15000	14500	17000
60	23	1900	2400	3200	3700	6800	8200	7100	8400	9000	11000	10500	13000	10500	13000	12000	15000	15000	17000
63	22	1900	2400	3200	3700	6800	8200	7100	8400	9000	11000	10500	13000	10500	13000	12000	15000	15000	17000
80	17.5	1900	2400	3200	3700	6800	8200	7100	8400	9000	11000	10500	13000	10500	13000	12000	15000	15000	17000
100	14	1900	2400	3200	3700	6800	8200	7100	8400	9000	11000	10500	13000	10500	13000	12000	15000	15000	17000
120	11.7	1900	2400	3200	3700	6800	8200	7100	8400	9000	11000	10500	13000	10500	13000	12000	15000	15000	17000
150	9.3	1900	2400	3200	3700	6800	8200	7100	8400	9000	11000	10500	13000	10500	13000	12000	15000	15000	17000
160	8.8	1900	2400	3200	3700	6800	8200	7100	8400	9000	11000	10500	13000	10500	13000	12000	15000	15000	17000
≥ 200 ≤ 7.0		1900	2400	3200	3700	6800	8200	7100	8400	9000	11000	10500	13000	10500	13000	12000	15000	15000	17000
Cuscinetto Bearing Lager		32005 25x47x15		32006 30x55x17		32008 40x68x19		32008 40x68x19		32010 50x80x20		32010 50x80x20		32010 50x80x20		32012 60x95x23		32015 75x115x25	

## Potenza Termica

## Thermal power

## Thermische Leistung

Nelle tabelle riportate nelle sezioni relative ad ogni tipologia di riduttore sono indicati i valori della potenza termica nominale  $P_{t0}$  (kW). Tale valore rappresenta la potenza massima applicabile all'entrata del riduttore, in servizio continuo a temperatura ambiente di 30°C, così che la temperatura dell'olio non oltrepassi il valore di 95°C, valore massimo ammesso nel caso di prodotti standard.

**Il valore di  $P_{t0}$  non deve essere preso in considerazione** se il funzionamento è continuo per un massimo di 1.5 ore seguito da pause di durata sufficiente (circa 1 – 2 ore) a ristabilire nel riduttore la temperatura ambiente.

I valori di  $P_{t0}$  devono essere corretti tramite i seguenti coefficienti, così da considerare le reali condizioni di funzionamento, ottenendo i valori di potenza termica corretta  $P_{tc}$ .

*The different sections dedicated to each type of gearbox contain tables reporting the values of rated thermal power  $P_{t0}$  (kW). Reported values correspond to the maximum admissible power at gearbox input, on continuous duty and with ambient temperature of 30°C, so that oil temperature does not exceed 95°C, which is the max. admissible value for standard products.*

**$P_{t0}$  value should not be taken into account** in case of continuous duty for max. 1.5 hours followed by pauses which are long enough to bring the gearbox back to ambient temperature (roughly 1 – 2 hours).

*In order to comply with the actual operating conditions,  $P_{t0}$  values should be corrected with the following coefficients, thus obtaining the values of corrected thermal power  $P_{tc}$ .*

Für jeden Getriebetyp gibt es Tabellen, die die Nennwerte der thermischen Leistung  $P_{t0}$  (kW) angeben. Die angegebenen Werte stellen die max. anwendbare Antriebsleistung der Getriebe im Dauerbetrieb mit einer Umgebungstemperatur von max. 30°C dar, sodass die Öltemperatur unter 95°C bleibt (max. Wert für Standardprodukte).

**$P_{t0}$  Wert darf nicht betrachtet werden**, falls Dauerbetrieb max. 1.5 Stunden dauert und von Stillstand gefolgt wird, der lang genug ist, damit das Getriebe zur Umgebungstemperatur zurück kommt. (ungefähr 1 – 2 Stunden).

$P_{t0}$  Werte sollen durch die folgenden Koeffizienten verbessert werden, Damit die realen Betriebsbedingungen wirklich in Betracht gezogen werden. Mit der folgenden Formel erhält man die Werte der korrekten thermischen Leistung  $P_{tc}$ .

$$P_{tc} = P_{t0} \cdot ft \cdot fv \cdot fu \quad (\text{kW})$$

Dove:

**ft** = coefficiente di temperatura (v. tab. 3)

Where:

**ft** = temperature coefficient (see table 3)

Dabei ist:

**ft** = Temperaturkoeffizient (siehe Tabelle 3)

Tab. 3

Ta (°C)	0	5	10	15	20	25	30	35	40	45	50
<b>ft</b>	1.46	1.38	1.31	1.23	1.15	1.1	1	0.92	0.85	0.77	0.69

(Dove Ta (°C) è la temperatura ambiente)

(Ta (°C) is the ambient temperature)

(Ta (°C) ist die Umgebungstemperatur)

**fv** = coefficiente di ventilazione

- fv= 1.45 con ventilazione forzata efficace con ventola dedicata
- fv= 1.25 con ventilazione forzata secondaria ad altri dispositivi (pulegge, ventole motore, ecc.)
- fv= 1 refrigerazione naturale (situazione standard)
- fv= 0.5 in ambiente chiuso e ristretto (carter)

**fv** = cooling coefficient

- fv= 1.45 forced cooling with specific fan
- fv= 1.25 forced cooling secondary to other devices (pulleys, motor fans, etc)
- fv= 1 natural cooling (standard)
- fv= 0.5 in a closed and narrow environment

**fv** = Luftkühlungskoeffizient

- fv= 1.45 Drucklüftung mit Sonderlüfterrad
- fv= 1.25 Drucklüftung nebensächlich zu anderen Vorrichtungen (Scheiben, Motorlüfterräder, usw.)
- fv= 1 natürliche Lüftung (Standard)
- fv= 0.5 in engem und geschlossenem Raum

**fu** = coefficiente di utilizzo (v. tab. 4)

**fu** = utilization coefficient (see table 4)

**fu** = Verwendungskoeffizient (siehe Tabelle 4)

Tab. 4

Dt (min)	10	20	30	40	50	60
<b>fu</b>	1.6	1.35	1.2	1.1	1.05	1

Dove Dt sono i minuti di funzionamento in un'ora

Dt is minutes of operation per hour

Dt steht für Betriebsminuten pro Stunde

## Selezione

### Scelta riduttore

A)  $n_1 = 1400, 2800, 900, 500 \text{ rpm}$

Si sceglierà nelle tabelle delle prestazioni dei riduttori un gruppo che in corrispondenza di un rapporto prossimo a quello calcolato ammetta una potenza:

## Selection

### Selecting a gearbox

A)  $n_1 = 1400, 2800, 900, 500 \text{ rpm}$

Consult the gear unit efficiency table; select a group whose ratio is close to the calculated ratio and which permits power:

## Wahl

### Wahl des Getriebes

A)  $n_1 = 1400, 2800, 900, 500 \text{ rpm}$

Aus der Tabelle der Leistungen der Untersetzungsgetriebe wählt man eine Baugruppe aus, die ein ähnliches Untersetzungsverhältnis zu dem berechneten Wert aufweist und die die folgende Leistung zulässt:

$$P \geq P' \times FS$$

### Scelta del motoriduttore

B)  $FS = 1$

Si cercherà nelle tabelle della prestazioni dei motoriduttori un gruppo la cui potenza  $P_1$  corrisponda alla  $P'$  calcolata.

C)  $FS \neq 1$

La scelta dovrà essere effettuata come al punto A) verificando che la grandezza del motore da installare sia compatibile con quelle ammesse dal riduttore (IEC); ovviamente la potenza installata dovrà corrispondere al valore  $P'$  richiesto.

Determinato il riduttore idoneo è necessario verificare che anche gli eventuali carichi aggiuntivi (radiali ed assiali) agenti sugli alberi in uscita e/o entrata rientrino nei valori ammissibili dati a catalogo.

In determinate condizioni applicative può diventare necessario verificare che la potenza assorbita dal riduttore non superi quella del limite termico riportata a catalogo, secondo quanto riportato a pag. A17 relativamente alla potenza termica.

### Selecting a gearmotor

B)  $FS = 1$

Consult the gear motor efficiency table and select a group having power  $P_1$  corresponding to calculated  $P'$ .

C)  $FS \neq 1$

Follow the instructions at point A), checking that the size of the motor to be installed is compatible with the gear unit (IEC); obviously, installed power must correspond to the required  $P'$  value.

After having selected the proper gearbox, it is necessary to check out that possible additional loads (radial or axial) on the input and /or output shafts fall within the values reported in the catalogue. Depending on the application, it might be necessary to check that the power absorbed by the gearbox does not exceed the thermal power limit reported in the catalogue as page A17.

### Wahl des Getriebemotors

B)  $FS = 1$

In den Leistungstabellen der Getriebemotoren sucht man eine Baugruppe, deren Leistung  $P_1$  der berechneten Leistung  $P'$  entspricht.

C)  $FS \neq 1$

Die Auswahl wird wie unter A) getroffen, wobei zu ueberpruefen ist, ob die Größe des zu installierenden Motors mit dem Untersetzungsgetriebe kompatibel ist (IEC); selbstverständlich muß die Einbauleistung dem erforderlichen Wert  $P'$  entsprechen.

Nachdem das geeignete Getriebe gewählt worden ist, muss es sichergestellt werden, das zusätzlichen Radial-oder Axialbelastungen auf die Antriebs-oder Abtriebswelle unter den im Katalog gegebenen Werten fallen. Abhängig von der Art der Anwendung ist es manchmal zu prüfen, dass die von Getriebe absorbierten Leistung unter der Wert der thermischen Leistung liegt, wie es in dem Katalog angegeben wird (Seite A17).

## Lubrificazione

Tutti i riduttori, eccetto X130 e K130, sono forniti completi di lubrificante sintetico a base PAG con indice di viscosità ISO VG320.

I cuscinetti dell'albero veloce vengono sempre lubrificati con grasso a base sintetica per tutte le posizioni di montaggio, solamente per le posizioni di montaggio B6 – B7, per una corretta lubrificazione, vengono ingrassati anche i cuscinetti dell'albero lento. Questo significa che solamente dalle posizioni di montaggio B6 – B7 si può passare a tutte le altre posizioni, modificando esclusivamente le quantità di olio, come indicato nelle relative tabelle; per quanto riguarda invece le posizioni di montaggio B3 – B8 – V5 – V6, possono essere intercambiabili solo tra di loro, senza modificare le quantità di olio.

### Attenzione!

per i riduttori a vite senza fine con precoppia HA – HF, la posizione di montaggio V5 non può essere intercambiabile con nessun'altra posizione; per quanto riguarda l'ingrassaggio dei cuscinetti dei riduttori combinati, la posizione di montaggio deve essere riferita al singolo riduttore.

Una scelta oculata del tipo di lubrificante, in funzione delle condizioni operative e ambientali, consente ai riduttori di raggiungere le prestazioni ottimali.

Le prestazioni dei riduttori indicate nelle tabelle dei dati tecnici sono state calcolate considerando l'impiego di olio sintetico.

### VISCOSITA'

E'uno dei parametri più importanti da considerare nella scelta di un olio ed è influenzabile da diversi parametri quali velocità, temperatura. Riportiamo sinteticamente le valutazioni generali per la scelta della giusta viscosità:

#### Viscosità alta

Usare per basse velocità di rotazione e/o temperature alte. (Una viscosità troppo bassa in queste condizioni operative causa una usura precoce).

#### Viscosità bassa

Usare per alte velocità di rotazione e/o temperature basse. (Una viscosità troppo elevata provoca diminuzione del rendimento e surriscaldamento).

## Lubrication

*All worm gearboxes, except for the type X130 and K130, are supplied with synthetic lubricant, PAG base, viscosity index ISO VG 320.*

*The bearings mounted on the input shaft are always supplied with synthetic -base grease for all mounting positions. For mounting positions B6 - B7, the output shaft bearings are also greased to ensure correct lubrication. This means that it is possible to switch from the mounting positions B6 - B7 to all the other positions, changing only the quantities of oil specified in the corresponding tables. Mounting positions B3 - B8 - V5 - V6 can be exchanged without changing the oil quantity.*

### Caution!

*for worm gearboxes with HA - HF pre-stage, the V5 mounting position cannot be interchangeable with any other position; as regards the greasing of the bearings of the combined gearboxes, the mounting position must refer to the single reducer.*

*Choose the lubricant according to operating and ambient conditions in order to ensure high gear unit performance.*

*Performance data, as shown in the specifications tables, refer to utilization of synthetic oil.*

### VISCOSITY

*It is the most important parameter to be considered when selecting an oil; it depends on various factors such as speed and temperature. Following are general guidelines for choosing the correct viscosity:*

#### High viscosity

*To be used for low rotation speed and/or high temperatures. (Under these operating conditions a low viscosity causes premature wear).*

#### Low viscosity

*To be used for high rotation speed and/or low temperatures. (High viscosity reduces efficiency and causes overheating).*

## Ölschmierung

Alle Schneckenradgetriebe mit Ausnahme der Ausführung X130 und K130, werden mit synthetischem Schmiermittel auf PAG Basis und Viskosität Index ISO VG 320 geliefert.

Die auf der Eingangswelle montierten Lager werden für alle Einbaulagen immer mit synthetischem Grundfett geliefert. Für die Einbaulagen B6 - B7 werden die Ausgangswellenlager ebenfalls gefettet, um eine korrekte Schmierung zu gewährleisten. Dies bedeutet, dass nur von den Montagepositionen B6 - B7 aus auf alle anderen Positionen gewechselt werden kann, wobei nur die in den entsprechenden Tabellen angegebenen Ölmengen geändert werden. Die Einbaulagen B3 - B8 - V5 - V6 können untereinander ausgetauscht werden, ohne die Ölmenge zu verändern.

### Achtung!

Bei Schneckengetrieben mit HA-HF-Vorstufe kann die V5-Einbaulage nicht mit einer anderen Position ausgetauscht werden. Bezüglich der Schmierung der Lager der kombinierten Getriebe muss sich die Einbaulage auf das einzelne Getriebe beziehen.

Das Untersetzungsgetriebe wird optimal arbeiten, wenn das richtige Schmiermittel je nach Betriebs- und Umgebungsbedingungen sorgfältig ausgewählt wird.

Daten über Getriebeleistung, wie es in den Tabellen der technischen Daten angegeben wird, beziehen sich auf Schmierung mit synthetischem Öl.

### VISKOSITÄT

Die Viskosität ist eines der wichtigsten Merkmale, die bei der Auswahl des richtigen Öls zu beachten sind; sie wird von verschiedenen Parametern wie Geschwindigkeit und Temperatur beeinflusst. Im folgenden fassen wir die wichtigsten allgemeinen Hinweise für die Wahl der richtigen Viskosität zusammen:

#### Hohe Viskosität

Geeignet für niedrige Drehzahlen bzw. hohe Temperaturen. (Eine zu geringe Viskosität verursacht unter diesen Betriebsbedingungen frühen Verschleiß).

#### Geringe Viskosität

Geeignet für hohe Drehzahlen bzw. niedrige Temperaturen. (Eine zu hohe Viskosität führt in diesem Fall zu einer Verringerung des Wirkungsgrades und zur Überhitzung).

**Lubrificazione**
**Lubrication**
**Ölschmierung**
**ADDITIVI**

In tutti gli oli minerali sono contenuti degli additivi antiusura, EP (più o meno energici), antiossidanti ed antischiuma. E' opportuno assicurarsi che essi siano blandi e non aggressivi nei confronti delle guarnizioni.

**BASE DELL'OLIO**

Può essere minerale o sintetica. L'olio sintetico, compensa il costo più elevato con una serie di vantaggi:

- a) minor coefficiente d'attrito (quindi migliore rendimento)
- b) migliore stabilità nel tempo (possibile lubrificazione a vita)
- c) migliore indice di viscosità (migliore adattabilità alle varie temperature).

L'olio a base minerale come vantaggi ha il minore costo e un migliore comportamento in rodaggio.

**ADDITIVES**

All mineral oils contain additives to protect against wear, EP (more or less strong), anti-oxidizing and anti-fothing. It is advisable to make sure that the action of such additives is bland and not too aggressive on the seals.

**OIL BASE**

May be mineral or synthetic. Synthetic oil compensates for the higher cost with a series of advantages :

- a) lower friction coefficient (consequently improved efficiency)
- b) better stability over time (possible life lubrication)
- c) better viscosity index (more adaptable to various temperatures).

Mineral-base oils offer the advantages of costing less and performing better during the running-in period.

**ZUSÄTZE**













Alle Mineralöle enthalten Antiverschleiß-Zusätze, EP (mehr oder weniger stark), Oxydationsschutzmittel und Mittel gegen Schaumbildung. Es soll sichergestellt werden, daß diese Zusätze schwach sind und die Dichtungen nicht angreifen.

**ÖLGRUNDLAGE**

Es kann sich dabei um Mineralöl oder synthetisches Öl handeln. Synthetisches Öl ist kostenintensiver, bietet jedoch viele Vorteile:

- a) geringerer Reibungskoeffizient (besserer Wirkungsgrad)
- b) höhere Stabilität über lange Zeit (lebenslange Schmierung möglich)
- c) besserer Viskositätsindex (passt sich besser an Temperaturschwankungen an).

Die Vorteile von Mineralöl sind die niedrigeren Kosten und das bessere Einfahrverhalten.

ISO VG		OLIO MINERALE / MINERAL OIL / MINERALÖL			OLIO SINTETICO / SYNTHETIC OIL / SYNTETISCHES ÖL				
		460	320	220	460	320	220	150	
Temperatura ambiente Amb. Temp. Ta (°C) Umgebungstemperatur		5° ÷ 45°	0° ÷ 40°	-5° ÷ 35°	-15° ÷ 100°	-20° ÷ 90°	-25° ÷ 80°	-30° ÷ 70°	
<b>MINERALE / MINERAL / MINERAL</b>									
FORNITORE / MANUFACTURER / HERSTELLER	MINERALE / MINER. / MINER.	SHELL 	Omala OIL 460	Omala OIL 320	Omala OIL 220				
		BP 	Energol GRXP 460	Energol GRXP 320	Energol GRXP 220				
		TEXACO 	Meropa 460	Meropa 320	Meropa 220				
		CASTROL 	Alpha SP 460	Alpha SP 320	Alpha SP 220				
		KLUBER 	Lamora 460	Lamora 320	Lamora 220				
		MOBIL 	Mobilgear 634	Mobilgear 632	Mobilgear 630				
	PAG	<b>Tecnologia PAG (polialcoliglicoli) / PAG Tecnology (polyalkyleneglycol) / PAG (Polyalkylglykole)</b>							
		SHELL 				Omala S4 WE 460	Omala S4 WE 320	Omala S4 WE 220	Omala S4 WE 150
		BP 				Energol SGXP460	Energol SGXP320	Energol SGXP220	Enersyn SG 150
		AGIP 				Synlube CLP 460	Synlube CLP 320	Synlube CLP 220	Agip Blasias S 150
PAO	<b>Tecnologia PAO (polialcoliolefini) / PAO Tecnology (polyalphaolefin) / PAO (Polyalphaolefine)</b>								
	SHELL 				Omala OIL RL/HD 460	Omala OIL RL/HD 320	Omala OIL RL/HD 220	Omala OIL RL/HD 150	
	CASTROL 				Alpha Synt 460	Alpha Synt 320	Alpha Synt 220	Alpha Synt 150	
	MOBIL 				SHC 634	SHC 632	SHC 630	SHC 629	

## Installazione

Fissare il riduttore in modo tale da evitare qualsiasi vibrazione e curare l'allineamento del riduttore con il motore e l'utenza utilizzando, quando è possibile, giunti di accoppiamento. Assicurarsi che gli organi da montare sui riduttori abbiano le tolleranze ISO h6 per gli alberi e ISO H7 per i fori. Se il riduttore viene installato all'aperto si consiglia l'utilizzo del tappo di sfiato con valvola, tranne le grandezze 30-40-50-63-75-89. Tutti i riduttori e motoriduttori citati nel presente manuale sono destinati ad un impiego industriale con temperatura ambiente da -20°C a +40°C ad una altitudine max di 1000 m slm.

Per tutte le altre avvertenze consultare il manuale di "uso e manutenzione" scaricabile dal sito [www.tramec.it](http://www.tramec.it)

## Installation

*The gearbox has to be mounted to prevent any vibration. Check carefully the alignment gearbox / motor / machine and use couplings whenever possible. Check that devices to be mounted on the gearbox feature ISO h6 tolerance for the shafts and ISO H7 for the holes. If the gearbox is installed outdoors, we recommend the use of the breather plug with valve, except size 30-40-50-63-75-89. All reducers and gear motors mentioned in this catalog are intended for industrial use and operation at a ambient temperature between -20°C and +40°C, at an altitude of max. 1000 m above sea level.*

*For all other instructions check the "Use and Maintenance Manual" which can be downloaded from our web site [www.tramec.it](http://www.tramec.it)*

## Einbau

Das Getriebe ist so zu installieren, dass allerart Schwingung vorbeugt wird. Auf die Fluchtung Getriebe / Motor / Maschine ist es besonders achtzugeben. Dabei sind Kupplungen womöglich zu benutzen. Die auf dem Getriebe montierten Elemente sollen die folgende Toleranz aufweisen: ISO h6 für die Wellen und ISO h7 für die Bohrungen. Abgesehen von Größen 30-40-50-63-75-89, die Anwendung einer Entlüftungsschraube mit Ventil wird empfohlen, wenn das Getriebe im Freien eingebaut wird. Alle im vorliegenden Katalog angegebenen Getriebe und Getriebemotoren sind für industriellen Einsatz in einer Umgebungstemperatur von -20°C bis +40°C und in einer max. Höhe von 1000 m über dem Meeresspiegel vorgesehen. Für weitere Anweisungen laden Sie die "Betriebs- und Instandhaltungsanweisung" aus unsere Webseite [www.tramec.it](http://www.tramec.it) herunter.

## Manutenzione

Tutti i riduttori a vite senza fine, eccetto X130 e K130, sono lubrificati a vita con olio sintetico tipo SHELL OMALA S4 WE 320. Non necessitano quindi di particolari manutenzioni se non il mantenimento della pulizia esterna, evitando l'uso di solventi per non danneggiare guarnizioni o anelli di tenuta, ed il rispetto di tutte le indicazioni e della eventuale sostituzione dell'olio negli intervalli programmati e riportati nel manuale di "uso e manutenzione" scaricabile dal sito [www.tramec.it](http://www.tramec.it)

## Maintenance

*All worm gearboxes, except for the type X130 and K130, are lubricated for life with synthetic oil SHELL OMALA S4 WE 320. For this reason they do not require any particular maintenance, except for external cleaning (avoid the use of solvents which might damage gaskets and oil seals) and observance of the schedules for oil change as reported in the "Use and Maintenance Manual" which can be downloaded from our web site [www.tramec.it](http://www.tramec.it)*

## Wartung

Alle Schneckengetriebe mit Ausnahme der Ausführung X130 und K130 sind mit synthetischem Öl SHELL OMALA S4 WE 320 lebenslang geschmiert. Deshalb brauchen sie kein besonderes Instandhalten außer Aussenreinigung und Befolgung der Zeitabstände für Ölwechsel, wie es in der "Betriebs- und Instandhaltungsanweisung" auf unsere Webseite [www.tramec.it](http://www.tramec.it) angegeben wird. Bei der Aussenreinigung benutzen Sie keine Lösemittel, weil sie die Dichtungen beschädigen.

## Verniciatura

Le carcasse in ghisa e le flange delle grandezze 90, 110 e 130 sono verniciate di colore BLU RAL 5010 mentre quelle in alluminio delle grandezze 89, 75, 63, 50, 40 e 30 sono sabbiate.

## Painting

*Size 90, 110 and 130 have cast iron housings and flanges painted BLUE RAL 5010. The housings of sizes 89, 75, 63, 50, 40 and 30 are made in aluminium and sandblasted.*

## Lackierung

Die Gehäuse der Größen 90, 110 und 130 bestehen aus Gusseisen und sind BLAU RAL 5010 lackiert. Für Größen 89, 75, 63, 50, 40 und 30 ist das Gehäuse aus Aluminium und sandgestrahlt.

## Rodaggio

Si consiglia di incrementare gradualmente nel tempo la potenza trasmessa oppure limitare il momento torcente resistente della macchina da comandare per le prime ore di funzionamento.

Per i riduttori lubrificati con olio minerale dopo le prime 500 - 1000 ore di funzionamento sostituire l'olio effettuando, se possibile, un accurato lavaggio interno del riduttore. Controllare periodicamente il livello del lubrificante ed effettuare il cambio dopo 4000 ore di funzionamento. Se è utilizzato olio sintetico il cambio può essere effettuato dopo 12500 ore di funzionamento. Quando il riduttore resta per lungo tempo inattivo in un ambiente con una elevata percentuale di umidità si consiglia di riempirlo completamente di olio. Naturalmente al momento della successiva messa in funzione sarà necessario ripristinare il livello del lubrificante.

## Running-in

*Increase the transmitted power gradually or limit the resistant torque of the driven machine for the first few operating hours.*

*Gear units lubricated with mineral oil, change the oil after the first 500 – 1000 operating hours and if possible thoroughly flush the inside of the gearbox. Check the lubricant level regularly and change after 4000 operating hours. If synthetic oil is used the oil change may take place after 12500 running hours. When the gearbox is left unused in a highly humid environment fill it completely with oil. Importantly the oil must be returned to the operating level before the unit is used again.*

## Einfahren

Es ist ratsam, die Leistung nur allmählich zu steigern oder das Widerstandsdrehmoment der Maschine in den ersten Betriebsstunden zu begrenzen.

Bei mit Mineralöl geschmierten Getrieben ist nach den ersten 500 bis 1000 Betriebsstunden ein Ölwechsel durchzuführen, dabei sollte das Getriebeinnere möglichst ausgespült werden. Von Zeit zu Zeit ist der Ölstand zu prüfen, alle 4000 Betriebsstunden sollte ein Ölwechsel stattfinden. Bei Verwendung von Synthetiköl kann der Ölwechsel alle 12500 Betriebsstunden erfolgen. Wenn das Getriebe lange Zeit in einem Raum mit hoher Luftfeuchtigkeit stillliegt, ist es ratsam, es ganz mit Öl zu füllen. Wird es danach wieder in Betrieb genommen, so ist natürlich vorher der richtige Ölstand wiederherzustellen.

**RIDUTTORI A VITE  
SENZA FINE X**
**X WORM GEARBOXES**
**SCHNECKENGETRIEBE X**
**X**

Caratteristiche	<i>Characteristics</i>	Merkmale	<b>B2</b>
Designazione	<i>Designation</i>	Bezeichnung	<b>B3</b>
Posizioni di montaggio	<i>Mounting position</i>	Einbaulage	<b>B4</b>
Posizione morsettiera	<i>Terminal board position</i>	Lage des Klemmbrett	<b>B4</b>
Lubrificazione	<i>Lubrication</i>	Schmierung	<b>B5</b>
Dati tecnici	<i>Technical data</i>	Technische Daten	<b>B6</b>
Momenti d'inerzia	<i>Moment of inertia</i>	Trägheitsmoment	<b>B15</b>
Dimensioni	<i>Dimensions</i>	Abmessungen	<b>B18</b>
Entrata supplementare	<i>Additional input</i>	Zusatzantrieb	<b>B23</b>
Limitatore di coppia cavo passante	<i>Torque limiter with through hollow shaft</i>	Drehmomentbegrenzer mit durchgehender Hohlwelle	<b>B23</b>
Accessori	<i>Accessories</i>	Zubehör	<b>B25</b>
Lista parti di ricambio	<i>Spare parts list</i>	Ersatzteilliste	<b>B26</b>
Targhetta	<i>Plate</i>	Schild	<b>B27</b>

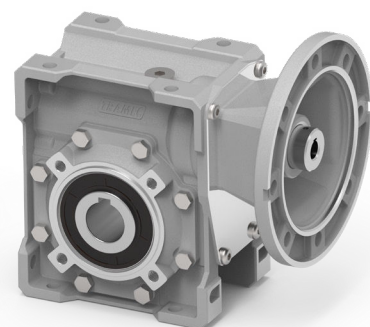
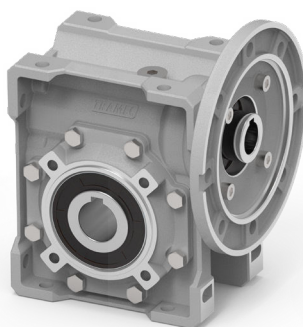
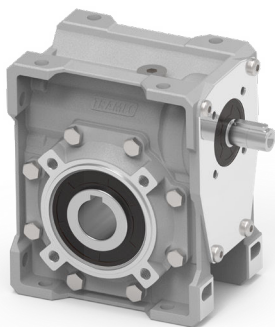
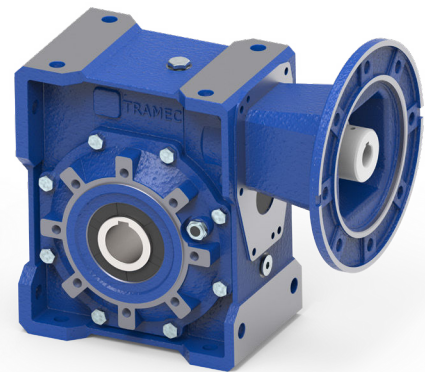
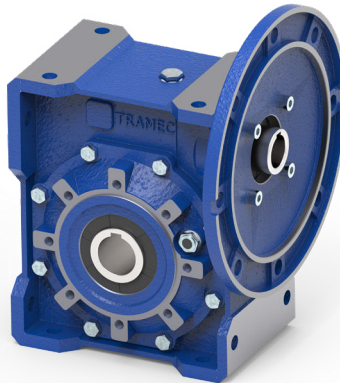
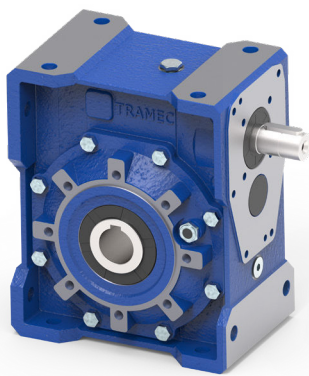

## Caratteristiche

- I riduttori a vite senza fine della serie X sono disponibili nelle versioni alberata XA e con predisposizione per attacco motore XF-XC. La grandezza 89 è disponibile solo nella versione XC.
- La versione XF (campana + giunto), caratterizzata da una più ampia versatilità ai diversi tipi di applicazioni, presenta un più elevato rendimento rispetto a quello della serie compatta XC la quale, a sua volta, presenta il vantaggio di un ingombro più ridotto.
- La carcassa monoblocco è in ghisa nelle grandezze 90, 110 e 130, in alluminio pressofuso per le grandezze 30, 40, 50, 63, 75 e 89.
- La vite senza fine è in acciaio legato cementato-temprato ed è rettificata.
- La corona ha il mozzo in ghisa con riporto di fusione dell'anello in bronzo.
- Le carcasse in ghisa sono verniciate BLU RAL5010 mentre quelle in alluminio sono sabbiate.
- Viene fornito l'albero uscita cavo di serie ed esiste un'ampia disponibilità di accessori: seconda entrata, cuscinetti conici sulla corona, flangia uscita, albero lento con 1 o 2 sporgenze, limitatore di coppia con cavo passante, braccio di reazione, kit protezione albero cavo, kit protezione limitatore di coppia.







## Characteristics

- *X series worm gearboxes are available in the following versions : XA with shaft, XF and XC suitable for motor mounting assembling. The size 89 is only available in the XC version.*
- *The XF version (bell + joint) suits a wider range of applications and provides higher efficiency than the XC compact version, which actually offers reduced space requirement.*
- *The enbloc housing is in cast-iron for sizes 90, 110 and 130, in die-cast aluminium for sizes 30, 40, 50, 63, 75 and 89.*
- *The worm shaft is in case-and quenchhardened alloy steel and ground.*
- *The worm wheel has a cast-iron hub provided with inserted cast-bronze ring.*
- *The housings in cast iron are painted BLUE RAL 5010, those in aluminium are sandblasted.*
- *The hollow output shaft is supplied as standard. A broad range of accessories is available: second input, tapered roller bearings on the worm wheel, output flange, single or double-extended output shaft, torque limiter with through hollow shaft, torque arm, hollow shaft protection kit, torque limiter protection kit.*

## Merkmale

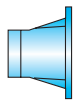
- Die Schneckengetriebe der Serie X sind in die Version XA mit Welle und XF / XC mit Motoranschluß lieferbar. Die Größe 89 ist nur in der XC-Version erhältlich.
- Die Version XF (Glocke + Kupplung), die sich durch ihre zahlreichen Anwendungsmöglichkeiten auszeichnet, bietet höhere Leistung als die Kompaktserie XC, die wiederum Vorteile im Sinne der Platzersparnis mit sich bringt.
- Das Blockgehäuse ist aus Gusseisen für die Baugrößen 90, 110 und 130, aus Aluminiumdruckguß die Baugrößen 30, 40, 50, 63, 75 und 89.
- Die Schnecke ist aus einsatzgehärtetem/abgeschrecktem und daraufhin geschliffenen Legierungsstahl.
- Das Schneckenrad besteht aus einer Nabe aus Gusseisen und einem aufgeschleuderten Gussbronze –Ring.
- Das Schneckenrad aus Gusseisen werden mit BLAU RAL 5010 lackiert, die aus Aluminium werden sandgestrahlt.
- Die Hohlwelle gehört zur serienmäßigen Ausstattung. Zahlreiches Zubehör ist lieferbar: zweiter Antrieb, Kegellager auf das Schneckenrad, Abtriebsflansch, Standard oder doppelseitig herausragende Abtriebswelle, Drehmomentbegrenzer mit durchgehender Hohlwelle, Drehmomentstütze, Schutzvorrichtung für Hohlwelle, Schutzvorrichtung für Drehmomentbegrenzer.

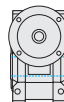
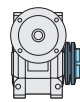
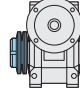
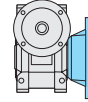
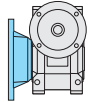
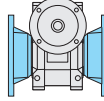
**Designazione**
**Designation**
**Bezeichnung**

Riduttore Gearbox Getriebe	Tipo entrata Input type Antriebsart	Grandezza Size Größe	Rapporto rid. Ratio Untersetzung	Predispos.att. mot. Motor coupling Motorschluss	Albero uscita cavo Hollow output shaft Abtriebshohlwelle	Limitatore di coppia. Torque limiter Drehmoment- begrenzer	Flangia in uscita. Output flange Abtriebsflansch	Seconda entrata Additional input Zusatzantrieb	Posizione di mont. Mounting position Einbaulage
<b>X</b>	<b>A</b>	<b>50</b>	<b>10/1</b>	<b>P.A.M</b>	<b>H25</b>	<b>LD</b>	<b>F1S</b>	<b>SeA</b>	<b>B3</b>
Riduttore a vite senza fine Wormgearbox Schneckengetriebe	 <b>A</b>  <b>C</b>  <b>F</b>	<b>30</b> <b>40</b> <b>50</b> <b>63</b> <b>75</b> <b>89*</b>  Alluminio Aluminium Aluminium <b>90</b> <b>110</b> <b>130</b>  Ghisa Cast iron Gusseisen	<b>5</b> <b>7.5</b> <b>10</b> <b>15</b> <b>20</b> <b>25</b> <b>30</b> <b>40</b> <b>50</b> <b>65</b> <b>80</b> <b>100</b>	<b>56</b> <b>63</b> <b>71</b> <b>80</b> <b>90</b> <b>100</b> <b>112</b> <b>132</b>	vedi tabelle  <i>see</i> <i>tables</i>  siehe Tabellen  	 <b>LD</b>   <b>LS</b>	 <b>F1D-F2D-F3D</b>   <b>F1S-F2S-F3S</b>   <b>F12-F22-F32</b>	 <b>SeA</b>	<b>B3, B6</b> <b>B7, B8</b> <b>V5, V6</b>

\*: 89 solo con tipo di entrata C

\*: 89 only with input type C

\*: 89 nur mit Antriebsart C

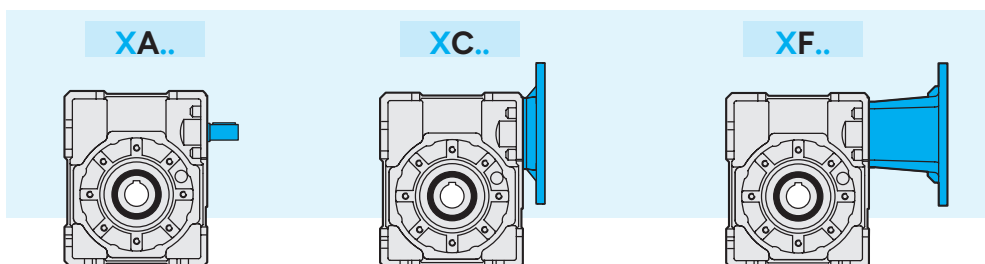
**Tipo entrata**
**Input type**
**Antriebstyp**

**Posizioni di montaggio**

**Mounting positions**

**Einbaulage**

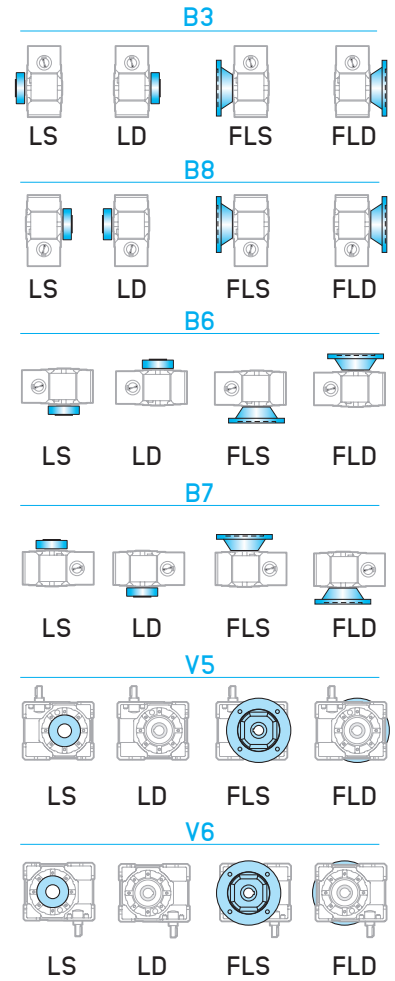
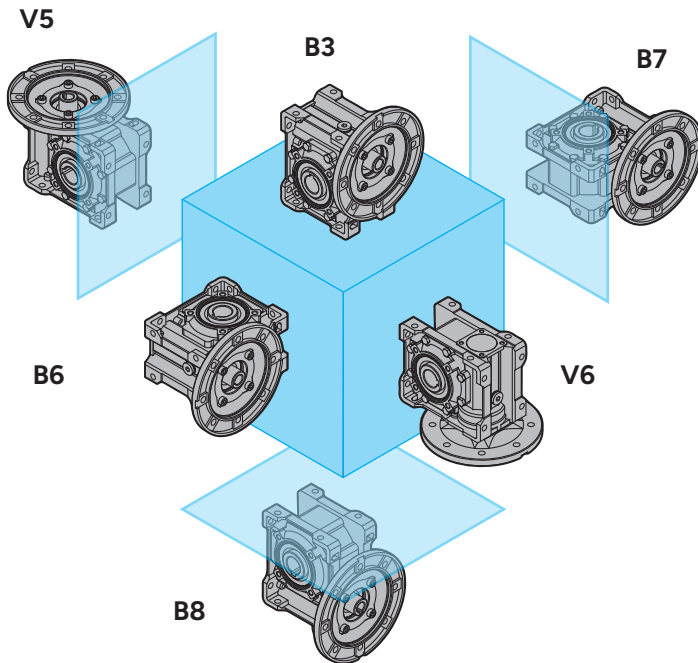

**Posizione morsettiera**

**Terminal board position**

**Lage des Klemmenkastens**

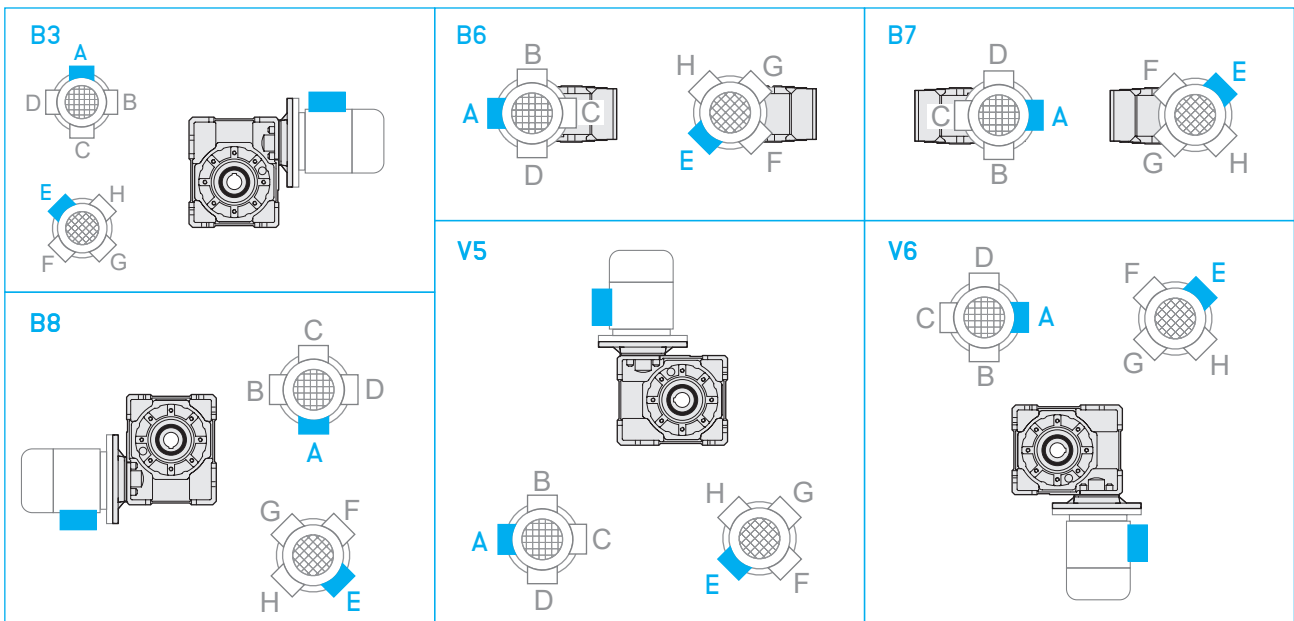

Specificare sempre in fase di ordinazione la posizione di montaggio e la forma costruttiva.  
Posizione morsettiera v. pag. B21-B22 (PM=1; PM=2)

Mounting position always to be specified when ordering.  
Terminal board position see page B21-B22 (PM=1; PM=2)

Bei der Bestellung immer die gewünschte Montageposition und Bauform angeben.  
Lage der Klemmenkaste Seite B21-B22 (PM=1; PM=2)

## Lubrificazione

## Lubrication

## Schmierung

I riduttori a vite senza fine serie X, tranne la grandezza 130, sono forniti completi di lubrificante sintetico a base PAG con indice di viscosità ISO VG320. Si raccomanda di precisare sempre, in fase di ordine, la posizione di lavoro desiderata.

Per ulteriori dettagli consultare pag. A19 paragrafo "Lubrificazione".

*X series worm gearboxes, except for the size 130, are supplied with synthetic lubricant, PAG base, viscosity index ISO VG320. Mounting position always to be specified when ordering.*

*For more details, see page A19, paragraph "Lubrication".*

Schneckengetriebe der Serie X, außer Groesse 130, werden mit synthetischem Schmiermittel auf PAG Basis und Viskosität Index ISO VG320 geliefert. Im Auftrag bitte immer die gewünschte Einbaulage angeben.

Weitere Einzelheiten finden Sie auf Seite A19, Absatz Schmierung.

### Posizione dei tappi e quantità di lubrificante (litri)

### Positions of the plugs and lubricant quantity (liters)

### Position der Kappen und Ölmenge (liter)

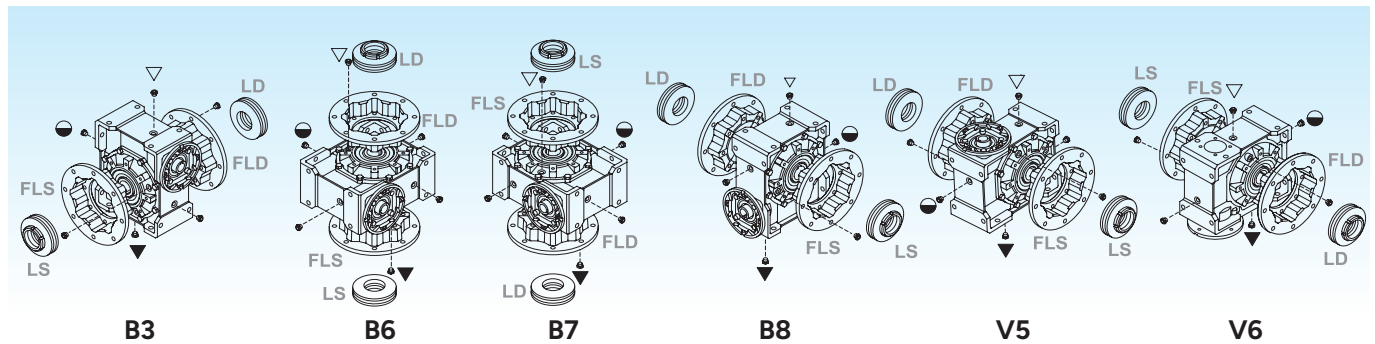

- ▽ Carico e sfiato / Filling and breather  
Einfüll und Entlüftung
- Livello / Level / Ölstand
- ▼ Scarico / Drain / Ablass

Nei corpi in alluminio 30, 40, 50, 63, 75 e 89 è presente un solo tappo di riempimento olio.

*30, 40, 50, 63, 75 and 89 aluminium housings have one oil filling plug only.*

30, 40, 50, 63, 75 und 89 Aluminiumgehäuse verfügen über 1 Einfüllschraube.

		Q.tà olio / Oil quantity / Schmiermittelmenge [lt]			
		Posizione di montaggio / Mounting position / Einbaulage			
		B3	B6 - B7	B8	V5 - V6
X	30	0.015	0.030	0.015	
	40	0.040	0.060	0.040	
	50	0.080	0.120	0.080	
	63	0.160	0.220	0.160	
	75	0.260	0.340	0.260	
	89	0.450	0.750	0.450	
	90	1.1	0.9	1	1.5
	110	2.2	1.8	1.6	2.6
130	3.6	3	2.5	3.8	

**Dati tecnici**
**Technical data**
**Technische Daten**

30	<b>n<sub>1</sub> = 2800</b>				<b>XA</b>		<b>XC - XF</b>								
	i <sub>n</sub>	n <sub>2</sub> [rpm]	Rd	P <sub>t0</sub>	T <sub>2M</sub> [Nm]	P [kW]	T <sub>2</sub> [Nm]	P <sub>1</sub> [kW]	FS'	Input - IEC					
										XC		XF			
	B5/B14		B5		B14										
Kg 1.4	5	560	0.89	—	14	0.92	5.6	0.37	2.5	63	56	63	56	63	56
	7.5	373	0.86		16	0.72	8	0.37	2.0						
	10	280	0.84		16	0.56	11	0.37	1.5						
	15	187	0.81		17	0.41	15	0.37	1.1						
	20	140	0.76		15	0.29	13	0.25	1.2						
	25	112	0.74		16	0.25	16	0.25	1.0						
	30	93	0.71		13	0.18	13	0.18	1.0						
	40	70	0.65		16	0.18	16	0.18	1.0						
	50	56	0.62		15	0.14	14	0.13	1.1						
	65	43	0.57		17	0.13	17	0.13	1.0						
80	35	0.54	13	0.09	13	0.09	1.0								
100	28	0.52	12	0.07	16	0.09	0.8	—							

30	<b>n<sub>1</sub> = 1400</b>				<b>XA</b>		<b>XC - XF</b>								
	i <sub>n</sub>	n <sub>2</sub> [rpm]	Rd	P <sub>t0</sub>	T <sub>2M</sub> [Nm]	P [kW]	T <sub>2</sub> [Nm]	P <sub>1</sub> [kW]	FS'	Input - IEC					
										XC		XF			
	B5/B14		B5		B14										
Kg 1.4	5	280	0.87	0.40	19	0.64	6.5	0.22	2.9	63	56	63	56	63	56
	7.5	187	0.84	0.40	21	0.49	9	0.22	2.2						
	10	140	0.82	0.40	22	0.40	12	0.22	1.8						
	15	93	0.77	0.30	22	0.28	17	0.22	1.3						
	20	70	0.72	0.20	19	0.19	18	0.18	1.1						
	25	56	0.69	0.20	21	0.18	21	0.18	1.0						
	30	47	0.66	0.20	20	0.15	18	0.13	1.1						
	40	35	0.59	0.20	21	0.13	21	0.13	1.0						
	50	28	0.55	0.20	19	0.10	17	0.09	1.1						
	65	22	0.51	0.10	20	0.09	20	0.09	1.0						
80	18	0.48	0.10	17	0.06	16	0.06	1.0							
100	14	0.45	0.10	14	0.05	18	0.06	0.8	—						

30	<b>n<sub>1</sub> = 900</b>				<b>XA</b>		<b>XC - XF</b>								
	i <sub>n</sub>	n <sub>2</sub> [rpm]	Rd	P <sub>t0</sub>	T <sub>2M</sub> [Nm]	P [kW]	T <sub>2</sub> [Nm]	P <sub>1</sub> [kW]	FS'	Input - IEC					
										XC		XF			
	B5/B14		B5		B14										
Kg 1.4	5	180	0.85	—	23	0.51	5.9	0.13	3.9	63	56	63	56	63	56
	7.5	120	0.82		25	0.38	9	0.13	2.9						
	10	90	0.80		25	0.30	11	0.13	2.3						
	15	60	0.75		25	0.21	15	0.13	1.6						
	20	45	0.69		22	0.15	19	0.13	1.2						
	25	36	0.66		24	0.14	23	0.13	1.1						
	30	30	0.63		21	0.10	18	0.09	1.2						
	40	23	0.55		24	0.10	21	0.09	1.1						
	50	18	0.52		21	0.08	16	0.06	1.1						
	65	14	0.48		22	0.07	20	0.06	1.1						
80	11	0.44	19	0.05	11	0.03	1.7								
100	9	0.42	15	0.03	13	0.03	1.1	—							

30	<b>n<sub>1</sub> = 500</b>				<b>XA</b>		<b>XC - XF</b>								
	i <sub>n</sub>	n <sub>2</sub> [rpm]	Rd	P <sub>t0</sub>	T <sub>2M</sub> [Nm]	P [kW]	T <sub>2</sub> [Nm]	P <sub>1</sub> [kW]	FS'	Input - IEC					
										XC		XF			
	B5/B14		B5		B14										
Kg 1.4	5	100	0.83	—	29	0.36	—	—	—	63	56	63	56	63	56
	7.5	67	0.80		31	0.27	—	—	—						
	10	50	0.77		31	0.21	—	—	—						
	15	33	0.72		31	0.15	—	—	—						
	20	25	0.66		26	0.10	—	—	—						
	25	20	0.62		27	0.09	—	—	—						
	30	17	0.59		25	0.07	—	—	—						
	40	13	0.51		28	0.07	—	—	—						
	50	10	0.48		25	0.06	—	—	—						
	65	8	0.43		25	0.05	—	—	—						
80	6	0.40	20	0.03	—	—	—								
100	5	0.38	16	0.02	—	—	—	—							

**\* ATTENZIONE:** la coppia massima utilizzabile [T<sub>2M</sub>] deve essere calcolata utilizzando il fattore di servizio:  
T<sub>2M</sub> = T<sub>2</sub> x FS'

**\* WARNING:** Maximum allowable torque [T<sub>2M</sub>] must be calculated using the following service factor:  
T<sub>2M</sub> = T<sub>2</sub> x FS'

**\* ACHTUNG:** das max. anwendbare Drehmoment [T<sub>2M</sub>] muss mit folgendem Betriebsfaktor berechnet werden:  
T<sub>2M</sub> = T<sub>2</sub> x FS'

Dati tecnici

Technical data

Technische Daten

40	$n_1 = 2800$				XA		XC - XF										
	$i_n$	$n_2$ [rpm]	Rd	$P_{t0}$	$T_{2M}$ [Nm]	P [kW]	$T_2$ [Nm]	$P_1$ [kW]	FS'	Input - IEC							
										XC			XF				
	B5/B14			B5			B14										
5	560	0.88		25	1.67	11.3	0.75	2.2	71	63	—	71	63	56	71	63	—
7.5	373	0.87		30	1.3	17	0.75	1.8									
10	280	0.86		31	1.1	22	0.75	1.4									
15	187	0.82		32	0.76	32	0.75	1.0									
20	140	0.80		31	0.57	30	0.55	1.0									
25	112	0.76		27	0.41	24	0.37	1.1									
30	93	0.73		35	0.47	28	0.37	1.3									
40	70	0.70		33	0.35	24	0.25	1.4									
50	56	0.65		30	0.27	28	0.25	1.1									
65	43	0.61		28	0.21	24	0.18	1.2									
80	35	0.58		26	0.16	21	0.13	1.3									
100	28	0.55		25	0.13	24	0.13	1.0									

40	$n_1 = 1400$				XA		XC - XF										
	$i_n$	$n_2$ [rpm]	Rd	$P_{t0}$	$T_{2M}$ [Nm]	P [kW]	$T_2$ [Nm]	$P_1$ [kW]	FS'	Input - IEC							
										XC			XF				
	B5/B14			B5			B14										
5	280	0.87	0.80	34	1.14	16.3	0.55	2.1	71	63	—	71	63	56	71	63	—
7.5	187	0.85	0.80	40	0.92	24	0.55	1.7									
10	140	0.83	0.70	41	0.73	31	0.55	1.3									
15	93	0.79	0.50	42	0.52	30	0.37	1.4									
20	70	0.76	0.50	40	0.39	38	0.37	1.0									
25	56	0.72	0.40	35	0.29	31	0.25	1.1									
30	47	0.68	0.40	41	0.29	35	0.25	1.2									
40	35	0.64	0.30	38	0.22	38	0.22	1.0									
50	28	0.59	0.30	38	0.19	36	0.18	1.1									
65	22	0.54	0.20	35	0.15	31	0.13	1.1									
80	18	0.52	0.20	33	0.12	31	0.11	1.1									
100	14	0.49	0.20	28	0.08	30	0.09	0.9									

40	$n_1 = 900$				XA		XC - XF										
	$i_n$	$n_2$ [rpm]	Rd	$P_{t0}$	$T_{2M}$ [Nm]	P [kW]	$T_2$ [Nm]	$P_1$ [kW]	FS'	Input - IEC							
										XC			XF				
	B5/B14			B5			B14										
5	180	0.85		42	0.93	16.7	0.37	2.5	71	63	—	71	63	56	71	63	—
7.5	120	0.83		48	0.72	25	0.37	2.0									
10	90	0.81		48	0.56	32	0.37	1.5									
15	60	0.76		49	0.40	45	0.37	1.1									
20	45	0.74		46	0.29	39	0.25	1.2									
25	36	0.69		42	0.23	33	0.18	1.3									
30	30	0.65		48	0.23	37	0.18	1.3									
40	23	0.61		42	0.16	33	0.13	1.3									
50	18	0.55		42	0.14	38	0.13	1.1									
65	14	0.51		39	0.11	32	0.09	1.2									
80	11	0.48		37	0.09	37	0.09	1.0									
100	9	0.45		30	0.06	29	0.06	1.0									

40	$n_1 = 500$				XA		XC - XF										
	$i_n$	$n_2$ [rpm]	Rd	$P_{t0}$	$T_{2M}$ [Nm]	P [kW]	$T_2$ [Nm]	$P_1$ [kW]	FS'	Input - IEC							
										XC			XF				
	B5/B14			B5			B14										
5	100	0.83		51	0.64	7.1	0.09	7.1	71	63	—	71	63	56	71	63	—
7.5	67	0.81		58	0.50	10	0.09	5.5									
10	50	0.79		59	0.39	14	0.09	4.4									
15	33	0.73		59	0.28	19	0.09	3.1									
20	25	0.70		55	0.20	24	0.09	2.3									
25	20	0.65		48	0.15	28	0.09	1.7									
30	17	0.61		58	0.17	31	0.09	1.8									
40	13	0.57		52	0.12	39	0.09	1.3									
50	10	0.51		51	0.11	44	0.09	1.2									
65	8	0.46		45	0.08	52	0.09	0.9									
80	6	0.44		42	0.06	61*	0.09	0.7*									
100	5	0.41		32	0.04	71*	0.09	0.4*									

\* **ATTENZIONE:** la coppia massima utilizzabile  $[T_{2M}]$  deve essere calcolata utilizzando il fattore di servizio:  
 $T_{2M} = T_2 \times FS'$

\* **WARNING:** Maximum allowable torque  $[T_{2M}]$  must be calculated using the following service factor:  
 $T_{2M} = T_2 \times FS'$

\* **ACHTUNG:** das max. anwendbare Drehmoment  $[T_{2M}]$  muss mit folgendem Betriebsfaktor berechnet werden:  
 $T_{2M} = T_2 \times FS'$

**Dati tecnici**
**Technical data**
**Technische Daten**

	<b>n<sub>1</sub> = 2800</b>				<b>XA</b>		<b>XC - XF</b>											
	i <sub>n</sub>	n <sub>2</sub> [rpm]	Rd	P <sub>to</sub>	T <sub>2M</sub> [Nm]	P [kW]	T <sub>2</sub> [Nm]	P <sub>1</sub> [kW]	FS'	Input - IEC								
										XC			XF					
										B5/B14			B5		B14			
50	5	560	0.89	—	44	2.9	22.8	1.5	1.9	80	71	—	80	71	63	80	71	—
	7.5	373	0.88		51	2.3	34	1.5	1.5									
	10	280	0.86		54	1.8	44	1.5	1.2									
	15	187	0.84		57	1.3	47	1.1	1.2									
	20	140	0.81		58	1.0	42	0.75	1.4									
	25	112	0.78		50	0.75	50	0.75	1.0									
	30	93	0.75		55	0.71	42	0.55	1.3									
	40	70	0.72		54	0.63	54	0.55	1.0									
	50	56	0.68		56	0.48	43	0.37	1.3									
	65	43	0.64		53	0.37	53	0.37	1.0									
	80	35	0.61		48	0.29	41	0.25	1.2									
	100	28	0.58		45	0.23	35	0.18	1.3									

	<b>n<sub>1</sub> = 1400</b>				<b>XA</b>		<b>XC - XF</b>											
	i <sub>n</sub>	n <sub>2</sub> [rpm]	Rd	P <sub>to</sub>	T <sub>2M</sub> [Nm]	P [kW]	T <sub>2</sub> [Nm]	P <sub>1</sub> [kW]	FS'	Input - IEC								
										XC			XF					
										B5/B14			B5		B14			
50	5	280	0.87	1.2	62	2.1	26.7	0.9	2.3	80	71	—	80	71	63	80	71	—
	7.5	187	0.86	1.2	70	1.6	40	0.9	1.8									
	10	140	0.84	1.0	73	1.3	52	0.9	1.4									
	15	93	0.80	0.80	74	0.90	74	0.9	1.0									
	20	70	0.78	0.70	75	0.71	58	0.55	1.3									
	25	56	0.74	0.60	65	0.51	47	0.37	1.4									
	30	47	0.71	0.60	66	0.46	53	0.37	1.2									
	40	35	0.67	0.50	69	0.38	68	0.37	1.0									
	50	28	0.62	0.40	70	0.33	53	0.25	1.3									
	65	22	0.58	0.40	64	0.25	64	0.25	1.0									
	80	18	0.54	0.40	60	0.20	53	0.18	1.1									
	100	14	0.51	0.30	55	0.16	45	0.13	1.2									

	<b>n<sub>1</sub> = 900</b>				<b>XA</b>		<b>XC - XF</b>											
	i <sub>n</sub>	n <sub>2</sub> [rpm]	Rd	P <sub>to</sub>	T <sub>2M</sub> [Nm]	P [kW]	T <sub>2</sub> [Nm]	P <sub>1</sub> [kW]	FS'	Input - IEC								
										XC			XF					
										B5/B14			B5		B14			
50	5	180	0.85	—	75	1.66	33.8	0.75	2.2	80	71	—	80	71	63	80	71	—
	7.5	120	0.84		83	1.23	50	0.75	1.6									
	10	90	0.82		86	0.98	66	0.75	1.3									
	15	60	0.78		88	0.71	68	0.55	1.3									
	20	45	0.75		87	0.54	59	0.37	1.5									
	25	36	0.71		75	0.40	70	0.37	1.1									
	30	30	0.67		79	0.37	79	0.37	1.0									
	40	23	0.63		75	0.28	67	0.25	1.1									
	50	18	0.59		80	0.26	78	0.25	1.0									
	65	14	0.54		74	0.20	67	0.18	1.1									
	80	11	0.51		67	0.16	56	0.13	1.2									
	100	9	0.47		58	0.12	45	0.09	1.3									

	<b>n<sub>1</sub> = 500</b>				<b>XA</b>		<b>XC - XF</b>											
	i <sub>n</sub>	n <sub>2</sub> [rpm]	Rd	P <sub>to</sub>	T <sub>2M</sub> [Nm]	P [kW]	T <sub>2</sub> [Nm]	P <sub>1</sub> [kW]	FS'	Input - IEC								
										XC			XF					
										B5/B14			B5		B14			
50	5	100	0.84	—	92	1.15	14.3	0.18	6.4	80	71	—	80	71	63	80	71	—
	7.5	67	0.82		100	0.85	21	0.18	4.7									
	10	50	0.80		104	0.68	28	0.18	3.8									
	15	33	0.75		106	0.49	39	0.18	2.7									
	20	25	0.72		104	0.38	50	0.18	2.1									
	25	20	0.68		88	0.27	58	0.18	1.5									
	30	17	0.63		98	0.27	65	0.18	1.5									
	40	13	0.59		95	0.21	81	0.18	1.2									
	50	10	0.54		94	0.18	93	0.18	1.0									
	65	8	0.50		86	0.14	56	0.09	1.5									
	80	6	0.46		77	0.11	63	0.09	1.2									
	100	5	0.43		61	0.07	74	0.09	0.8									

**\* ATTENZIONE:** la coppia massima utilizzabile [T<sub>2M</sub>] deve essere calcolata utilizzando il fattore di servizio:  
 $T_{2M} = T_2 \times FS'$

**\* WARNING:** Maximum allowable torque [T<sub>2M</sub>] must be calculated using the following service factor:  
 $T_{2M} = T_2 \times FS'$

**\* ACHTUNG:** das max. anwendbare Drehmoment [T<sub>2M</sub>] muss mit folgendem Betriebsfaktor berechnet werden:  
 $T_{2M} = T_2 \times FS'$

Dati tecnici

Technical data

Technische Daten

63	<b>n<sub>1</sub> = 2800</b>				<b>XA</b>		<b>XC - XF</b>											
	i <sub>n</sub>	n <sub>2</sub> [rpm]	Rd	P <sub>to</sub>	T <sub>2M</sub> [Nm]	P [kW]	T <sub>2</sub> [Nm]	P <sub>1</sub> [kW]	FS'	Input - IEC								
										XC			XF					
	B5/B14			B5			B14											
Kg 6.6	5	560	0.89	—	79	5.2	45.5	3	1.7	90	80	—	90	80	71	90	80	—
	7.5	373	0.88		88	3.9	68	3	1.3									
	10	280	0.87		94	3.2	89	3	1.1									
	15	187	0.84		98	2.3	95	2.2	1.0									
	20	140	0.83		110	1.9	85	1.5	1.3									
	25	112	0.81		93	1.4	76	1.1	1.2									
	30	93	0.77		110	1.4	87	1.1	1.3									
	40	70	0.74		117	1.2	111	1.1	1.1									
	50	56	0.70		97	0.81	90	0.75	1.1									
	65	43	0.67		98	0.66	81	0.55	1.2									
80	35	0.64	91	0.52	65	0.37	1.4											
100	28	0.60	83	0.41	75	0.37	1.1											

63	<b>n<sub>1</sub> = 1400</b>				<b>XA</b>		<b>XC - XF</b>											
	i <sub>n</sub>	n <sub>2</sub> [rpm]	Rd	P <sub>to</sub>	T <sub>2M</sub> [Nm]	P [kW]	T <sub>2</sub> [Nm]	P <sub>1</sub> [kW]	FS'	Input - IEC								
										XC			XF					
	B5/B14			B5			B14											
Kg 6.6	5	280	0.88	1.8	111	3.7	54	1.8	2.0	90	80	—	90	80	71	90	80	—
	7.5	187	0.87	1.8	120	2.7	80	1.8	1.5									
	10	140	0.85	1.6	127	2.2	105	1.8	1.2									
	15	93	0.81	1.2	130	1.6	125	1.5	1.1									
	20	70	0.80	1.2	144	1.3	120	1.1	1.2									
	25	56	0.77	1.0	118	0.90	118	0.9	1.0									
	30	47	0.73	0.90	142	0.95	134	0.9	1.1									
	40	35	0.69	0.80	150	0.79	142	0.75	1.1									
	50	28	0.65	0.70	122	0.55	122	0.55	1.0									
	65	22	0.61	0.60	122	0.45	100	0.37	1.2									
80	18	0.58	0.60	113	0.36	79	0.25	1.4										
100	14	0.53	0.50	102	0.28	91	0.25	1.1										

63	<b>n<sub>1</sub> = 900</b>				<b>XA</b>		<b>XC - XF</b>											
	i <sub>n</sub>	n <sub>2</sub> [rpm]	Rd	P <sub>to</sub>	T <sub>2M</sub> [Nm]	P [kW]	T <sub>2</sub> [Nm]	P <sub>1</sub> [kW]	FS'	Input - IEC								
										XC			XF					
	B5/B14			B5			B14											
Kg 6.6	5	180	0.87	—	135	2.9	69	1.5	1.9	90	80	—	90	80	71	90	80	—
	7.5	120	0.85		144	2.1	102	1.5	1.4									
	10	90	0.83		150	1.7	133	1.5	1.1									
	15	60	0.79		152	1.2	139	1.1	1.1									
	20	45	0.77		167	1.0	123	0.75	1.4									
	25	36	0.74		140	0.71	109	0.55	1.3									
	30	30	0.70		164	0.74	122	0.55	1.3									
	40	23	0.66		171	0.61	154	0.55	1.1									
	50	18	0.61		141	0.44	120	0.37	1.2									
	65	14	0.57		139	0.35	98	0.25	1.4									
80	11	0.54	128	0.28	115	0.25	1.1											
100	9	0.50	115	0.22	95	0.18	1.2											

63	<b>n<sub>1</sub> = 500</b>				<b>XA</b>		<b>XC - XF</b>											
	i <sub>n</sub>	n <sub>2</sub> [rpm]	Rd	P <sub>to</sub>	T <sub>2M</sub> [Nm]	P [kW]	T <sub>2</sub> [Nm]	P <sub>1</sub> [kW]	FS'	Input - IEC								
										XC			XF					
	B5/B14			B5			B14											
Kg 6.6	5	100	0.85	—	169	2.08	20	0.25	8.3	90	80	—	90	80	71	90	80	—
	7.5	67	0.83		177	1.5	30	0.25	5.9									
	10	50	0.81		182	1.2	39	0.25	4.7									
	15	33	0.76		184	0.84	55	0.25	3.4									
	20	25	0.74		200	0.70	71	0.25	2.8									
	25	20	0.71		165	0.49	85	0.25	1.9									
	30	17	0.65		195	0.52	94	0.25	2.1									
	40	13	0.62		201	0.43	118	0.25	1.7									
	50	10	0.56		165	0.31	135	0.25	1.2									
	65	8	0.52		161	0.25	163	0.25	1.0									
80	6	0.50	148	0.19	137	0.18	1.1											
100	5	0.45	122	0.14	77	0.09	1.6											

\* **ATTENZIONE:** la coppia massima utilizzabile [T<sub>2M</sub>] deve essere calcolata utilizzando il fattore di servizio:  
T<sub>2M</sub> = T<sub>2</sub> x FS'

\* **WARNING:** Maximum allowable torque [T<sub>2M</sub>] must be calculated using the following service factor:  
T<sub>2M</sub> = T<sub>2</sub> x FS'

\* **ACHTUNG:** das max. anwendbare Drehmoment [T<sub>2M</sub>] muss mit folgendem Betriebsfaktor berechnet werden:  
T<sub>2M</sub> = T<sub>2</sub> x FS'

**Dati tecnici**
**Technical data**
**Technische Daten**

75	<b>n<sub>1</sub> = 2800</b>				<b>XA</b>		<b>XC - XF</b>													
	i <sub>n</sub>	n <sub>2</sub> [rpm]	Rd	P <sub>to</sub>	T <sub>2M</sub> [Nm]	P [kW]	T <sub>2</sub> [Nm]	P <sub>1</sub> [kW]	FS'	Input - IEC										
										XC				XF						
											B5		B14							
				B5/B14																
Kg 9.0	7.5	373	0.89	—	131	5.8	125	5.5	1.0	112 100	90	—	—	112 100	90	80	112 100	90	—	
	10	280	0.88		143	4.8	120	4	1.2											71
	15	187	0.85		152	3.5	131	3	1.2											
	20	140	0.84		172	3.0	171	3	1.0											
	25	112	0.82		155	2.2	154	2.2	1.0											
	30	93	0.78		170	2.1	120	1.5	1.4											
	40	70	0.75		183	1.8	154	1.5	1.2											
	50	56	0.73		166	1.3	136	1.1	1.2											
	65	43	0.69		155	1.0	114	0.75	1.4											
	80	35	0.66		145	0.80	135	0.75	1.1											
100	28	0.62	131	0.62	159	0.75	0.8													

75	<b>n<sub>1</sub> = 1400</b>				<b>XA</b>		<b>XC - XF</b>													
	i <sub>n</sub>	n <sub>2</sub> [rpm]	Rd	P <sub>to</sub>	T <sub>2M</sub> [Nm]	P [kW]	T <sub>2</sub> [Nm]	P <sub>1</sub> [kW]	FS'	Input - IEC										
										XC				XF						
											B5		B14							
				B5/B14																
Kg 9.0	7.5	187	0.87	2.5	180	4.0	178	4	1.0	112 100	90	—	—	112 100	90	80	112 100	90	—	
	10	140	0.86	2.3	193	3.3	176	3	1.1											71
	15	93	0.83	1.9	202	2.4	187	2.2	1.1											
	20	70	0.81	1.7	226	2.0	199	1.8	1.1											
	25	56	0.78	1.5	202	1.5	200	1.5	1.0											
	30	47	0.74	1.2	220	1.5	167	1.1	1.3											
	40	35	0.71	1.1	235	1.2	213	1.1	1.1											
	50	28	0.67	1.0	211	0.92	206	0.9	1.0											
	65	22	0.63	0.90	195	0.70	154	0.55	1.3											
	80	18	0.60	0.80	182	0.55	180	0.55	1.0											
100	14	0.56	0.70	162	0.43	210	0.55	0.8												

75	<b>n<sub>1</sub> = 900</b>				<b>XA</b>		<b>XC - XF</b>													
	i <sub>n</sub>	n <sub>2</sub> [rpm]	Rd	P <sub>to</sub>	T <sub>2M</sub> [Nm]	P [kW]	T <sub>2</sub> [Nm]	P <sub>1</sub> [kW]	FS'	Input - IEC										
										XC				XF						
											B5		B14							
				B5/B14																
Kg 9.0	7.5	120	0.86	—	215	3.1	205	3	1.0	112 100	90	—	—	112 100	90	80	112 100	90	—	
	10	90	0.84		229	2.6	197	2.2	1.2											71
	15	60	0.81		237	1.9	231	1.8	1.0											
	20	45	0.78		263	1.6	250	1.5	1.1											
	25	36	0.76		233	1.2	221	1.1	1.1											
	30	30	0.71		254	1.1	249	1.1	1.0											
	40	23	0.67		270	0.94	214	0.75	1.3											
	50	18	0.64		241	0.71	186	0.55	1.3											
	65	14	0.59		221	0.54	151	0.37	1.5											
	80	11	0.56		205	0.43	177	0.37	1.2											
100	9	0.52	184	0.34	203	0.37	0.9													

75	<b>n<sub>1</sub> = 500</b>				<b>XA</b>		<b>XC - XF</b>													
	i <sub>n</sub>	n <sub>2</sub> [rpm]	Rd	P <sub>to</sub>	T <sub>2M</sub> [Nm]	P [kW]	T <sub>2</sub> [Nm]	P <sub>1</sub> [kW]	FS'	Input - IEC										
										XC				XF						
											B5		B14							
				B5/B14																
Kg 9.0	7.5	67	0.84	—	265	2.2	90	0.75	2.9	112 100	90	—	—	112 100	90	80	112 100	90	—	
	10	50	0.82		279	1.8	118	0.75	2.4											71
	15	33	0.78		286	1.3	167	0.75	1.7											
	20	25	0.75		315	1.1	216	0.75	1.5											
	25	20	0.72		278	0.80	260	0.75	1.1											
	30	17	0.67		302	0.79	288	0.75	1.1											
	40	13	0.63		317	0.66	265	0.55	1.2											
	50	10	0.59		282	0.50	210	0.37	1.3											
	65	8	0.55		257	0.38	251	0.37	1.0											
	80	6	0.52		238	0.30	197	0.25	1.2											
100	5	0.47	206	0.23	161	0.18	1.3													

\* **ATTENZIONE:** la coppia massima utilizzabile [T<sub>2M</sub>] deve essere calcolata utilizzando il fattore di servizio:  
 $T_{2M} = T_2 \times FS'$

\* **WARNING:** Maximum allowable torque [T<sub>2M</sub>] must be calculated using the following service factor:  
 $T_{2M} = T_2 \times FS'$

\* **ACHTUNG:** das max. anwendbare Drehmoment [T<sub>2M</sub>] muss mit folgendem Betriebsfaktor berechnet werden:  
 $T_{2M} = T_2 \times FS'$

**Dati tecnici**
**Technical data**
**Technische Daten**

89	<b>n<sub>1</sub> = 2800</b>				<b>XC</b>			Input - IEC		
	i <sub>n</sub>	n <sub>2</sub> [rpm]	Rd	P <sub>to</sub>	T <sub>2</sub> [Nm]	P <sub>1</sub> [kW]	FS'	XC		
								B5/B14		
 13.0	7.5	373	0.89	—	171	<b>7.5</b>	1.2	112 100	90	—
	10	280	0.88		165	<b>5.5</b>	1.3			
	15	187	0.86		241	<b>5.5</b>	1.0			
	20	140	0.84		230	<b>4</b>	1.2			
	25	112	0.83		212	<b>3</b>	1.2			
	30	93	0.79		243	<b>3</b>	1.1			
	40	70	0.77		230	<b>2.2</b>	1.3			
	50	56	0.74		278	<b>2.2</b>	1.0			
	65	43	0.71		235	<b>1.5</b>	1.1			
	80	35	0.68		205	<b>1.1</b>	1.2			
100	28	0.64	163	<b>0.75</b>	1.3	—	80			

89	<b>n<sub>1</sub> = 1400</b>				<b>XC</b>			Input - IEC		
	i <sub>n</sub>	n <sub>2</sub> [rpm]	Rd	P <sub>to</sub>	T <sub>2</sub> [Nm]	P <sub>1</sub> [kW]	FS'	XC		
								B5/B14		
 13.0	7.5	187	0.88	3.0	247	<b>5.5</b>	1.2	112 100	90	—
	10	140	0.86	2.5	236	<b>4</b>	1.3			
	15	93	0.84	2.2	256	<b>3</b>	1.2			
	20	70	0.82	2.0	334	<b>3</b>	1.1			
	25	56	0.80	1.8	299	<b>2.2</b>	1.1			
	30	47	0.76	1.5	340	<b>2.2</b>	1.0			
	40	35	0.72	1.3	355	<b>1.8</b>	1.1			
	50	28	0.69	1.1	353	<b>1.5</b>	1.0			
	65	22	0.65	1.0	317	<b>1.1</b>	1.0			
	80	18	0.63	1.0	309	<b>0.9</b>	1.0			
100	14	0.58	0.80	217	<b>0.55</b>	1.2	—	80		

89	<b>n<sub>1</sub> = 900</b>				<b>XC</b>			Input - IEC		
	i <sub>n</sub>	n <sub>2</sub> [rpm]	Rd	P <sub>to</sub>	T <sub>2</sub> [Nm]	P <sub>1</sub> [kW]	FS'	XC		
								B5/B14		
 13.0	7.5	120	0.86	—	206	<b>3</b>	1.7	112 100	90	—
	10	90	0.85		270	<b>3</b>	1.3			
	15	60	0.82		286	<b>2.2</b>	1.3			
	20	45	0.79		371	<b>2.2</b>	1.1			
	25	36	0.77		369	<b>1.8</b>	1.0			
	30	30	0.73		416	<b>1.8</b>	1.0			
	40	23	0.69		440	<b>1.5</b>	1.0			
	50	18	0.66		384	<b>1.1</b>	1.0			
	65	14	0.62		319	<b>0.75</b>	1.1			
	80	11	0.59		274	<b>0.55</b>	1.2			
100	9	0.54	313	<b>0.55</b>	1.0	—	80			

89	<b>n<sub>1</sub> = 500</b>				<b>XC</b>			Input - IEC		
	i <sub>n</sub>	n <sub>2</sub> [rpm]	Rd	P <sub>to</sub>	T <sub>2</sub> [Nm]	P <sub>1</sub> [kW]	FS'	XC		
								B5/B14		
 13.0	7.5	67	0.84	—	91	<b>0.75</b>	4.7	112 100	90	—
	10	50	0.83		118	<b>0.75</b>	3.7			
	15	33	0.79		169	<b>0.75</b>	2.7			
	20	25	0.76		219	<b>0.75</b>	2.3			
	25	20	0.74		265	<b>0.75</b>	1.7			
	30	17	0.68		294	<b>0.75</b>	1.6			
	40	13	0.65		371	<b>0.75</b>	1.4			
	50	10	0.61		439	<b>0.75</b>	1.1			
	65	8	0.57		388	<b>0.55</b>	1.1			
	80	6	0.54		305	<b>0.37</b>	1.3			
100	5	0.49	344	<b>0.37</b>	1.0	—	80			

**\* ATTENZIONE:** la coppia massima utilizzabile [T<sub>2M</sub>] deve essere calcolata utilizzando il fattore di servizio:  
T<sub>2M</sub> = T<sub>2</sub> x FS'

**\* WARNING:** Maximum allowable torque [T<sub>2M</sub>] must be calculated using the following service factor:  
T<sub>2M</sub> = T<sub>2</sub> x FS'

**\* ACHTUNG:** das max. anwendbare Drehmoment [T<sub>2M</sub>] muss mit folgendem Betriebsfaktor berechnet werden:  
T<sub>2M</sub> = T<sub>2</sub> x FS'

**Dati tecnici**
**Technical data**
**Technische Daten**

90	<b>n<sub>1</sub> = 2800</b>				<b>XA</b>		<b>XC - XF</b>											
	i <sub>n</sub>	n <sub>2</sub> [rpm]	Rd	P <sub>to</sub>	T <sub>2M</sub> [Nm]	P [kW]	T <sub>2</sub> [Nm]	P <sub>1</sub> [kW]	FS'	Input - IEC								
										XC			XF					
	B5/B14			B5			B14											
 23.6	7.5	373	0.89	—	209	9.2	171	7.5	1.2	112 100	90	—	112 100	90	80	112 100	90	—
	10	280	0.88		223	7.4	165	5.5	1.3									
	15	187	0.86		241	5.5	241	5.5	1.0									
	20	140	0.84		272	4.7	230	4	1.2									
	25	112	0.83		255	3.6	212	3	1.2									
	30	93	0.79		270	3.3	243	3	1.1									
	40	70	0.77		293	2.8	230	2.2	1.3									
	50	56	0.74		278	2.2	278	2.2	1.0									
	65	43	0.71		250	1.6	235	1.5	1.1									
	80	35	0.68		238	1.3	205	1.1	1.2									
100	28	0.64	212	0.97	163	0.75	1.3											

90	<b>n<sub>1</sub> = 1400</b>				<b>XA</b>		<b>XC - XF</b>											
	i <sub>n</sub>	n <sub>2</sub> [rpm]	Rd	P <sub>to</sub>	T <sub>2M</sub> [Nm]	P [kW]	T <sub>2</sub> [Nm]	P <sub>1</sub> [kW]	FS'	Input - IEC								
										XC			XF					
	B5/B14			B5			B14											
 23.6	7.5	187	0.88	3.0	290	6.5	247	5.5	1.2	112 100	90	—	112 100	90	80	112 100	90	—
	10	140	0.86	2.5	305	5.2	236	4	1.3									
	15	93	0.84	2.2	320	3.7	256	3	1.2									
	20	70	0.82	2.0	360	3.2	334	3	1.1									
	25	56	0.80	1.8	332	2.4	299	2.2	1.1									
	30	47	0.76	1.5	350	2.3	340	2.2	1.0									
	40	35	0.72	1.3	377	1.9	355	1.8	1.1									
	50	28	0.69	1.1	353	1.5	353	1.5	1.0									
	65	22	0.65	1.0	317	1.1	317	1.1	1.0									
	80	18	0.63	1.0	309	0.90	309	0.9	1.0									
100	14	0.58	0.80	264	0.67	217	0.55	1.2										

90	<b>n<sub>1</sub> = 900</b>				<b>XA</b>		<b>XC - XF</b>											
	i <sub>n</sub>	n <sub>2</sub> [rpm]	Rd	P <sub>to</sub>	T <sub>2M</sub> [Nm]	P [kW]	T <sub>2</sub> [Nm]	P <sub>1</sub> [kW]	FS'	Input - IEC								
										XC			XF					
	B5/B14			B5			B14											
 23.6	7.5	120	0.86	—	345	5.0	206	3	1.7	112 100	90	—	112 100	90	80	112 100	90	—
	10	90	0.85		362	4.0	270	3	1.3									
	15	60	0.82		377	2.9	286	2.2	1.3									
	20	45	0.79		419	2.5	371	2.2	1.1									
	25	36	0.77		385	1.9	369	1.8	1.0									
	30	30	0.73		416	1.8	416	1.8	1.0									
	40	23	0.69		440	1.5	440	1.5	1.0									
	50	18	0.66		398	1.1	384	1.1	1.0									
	65	14	0.62		358	0.84	319	0.75	1.1									
	80	11	0.59		337	0.68	274	0.55	1.2									
100	9	0.54	313	0.55	313	0.55	1.0											

90	<b>n<sub>1</sub> = 500</b>				<b>XA</b>		<b>XC - XF</b>											
	i <sub>n</sub>	n <sub>2</sub> [rpm]	Rd	P <sub>to</sub>	T <sub>2M</sub> [Nm]	P [kW]	T <sub>2</sub> [Nm]	P <sub>1</sub> [kW]	FS'	Input - IEC								
										XC			XF					
	B5/B14			B5			B14											
 23.6	7.5	67	0.84	—	430	3.6	91	0.75	4.7	112 100	90	—	112 100	90	80	112 100	90	—
	10	50	0.83		443	2.8	118	0.75	3.7									
	15	33	0.79		456	2.0	169	0.75	2.7									
	20	25	0.76		502	1.7	219	0.75	2.3									
	25	20	0.74		459	1.3	265	0.75	1.7									
	30	17	0.68		483	1.2	294	0.75	1.6									
	40	13	0.65		512	1.0	371	0.75	1.4									
	50	10	0.61		467	0.80	439	0.75	1.1									
	65	8	0.57		417	0.59	388	0.55	1.1									
	80	6	0.54		391	0.48	305	0.37	1.3									
100	5	0.49	345	0.37	344	0.37	1.0											

**\* ATTENZIONE:** la coppia massima utilizzabile [T<sub>2M</sub>] deve essere calcolata utilizzando il fattore di servizio:  
 $T_{2M} = T_2 \times FS'$

**\* WARNING:** Maximum allowable torque [T<sub>2M</sub>] must be calculated using the following service factor:  
 $T_{2M} = T_2 \times FS'$

**\* ACHTUNG:** das max. anwendbare Drehmoment [T<sub>2M</sub>] muss mit folgendem Betriebsfaktor berechnet werden:  
 $T_{2M} = T_2 \times FS'$

Dati tecnici

Technical data

Technische Daten

110	<b>n<sub>1</sub> = 2800</b>				<b>XA</b>		<b>XC - XF</b>											
	i <sub>n</sub>	n <sub>2</sub> [rpm]	Rd	P <sub>to</sub>	T <sub>2M</sub> [Nm]	P [kW]	T <sub>2</sub> [Nm]	P <sub>1</sub> [kW]	FS'	Input - IEC								
										XC			XF					
	B5/B14			B5			B14											
44.0	7.5	373	0.89	—	345	15.1	343	15	1.0	132	112 100	—	132	112 100	90	132	—	—
	10	280	0.88		368	12.2	332	11	1.1									
	15	187	0.86		404	9.2	331	7.5	1.2									
	20	140	0.85		465	8.0	435	7.5	1.1									
	25	112	0.84		441	6.2	393	5.5	1.1									
	30	93	0.80		459	5.6	450	5.5	1.0									
	40	70	0.78		503	4.7	424	4	1.2	—	90	—	90	—	—	—	—	
	50	56	0.76		476	3.7	388	3	1.2									
	65	43	0.73		417	2.6	354	2.2	1.2									
	80	35	0.70		400	2.1	287	1.5	1.4									
	100	28	0.66		364	1.6	339	1.5	1.1									

110	<b>n<sub>1</sub> = 1400</b>				<b>XA</b>		<b>XC - XF</b>											
	i <sub>n</sub>	n <sub>2</sub> [rpm]	Rd	P <sub>to</sub>	T <sub>2M</sub> [Nm]	P [kW]	T <sub>2</sub> [Nm]	P <sub>1</sub> [kW]	FS'	Input - IEC								
										XC			XF					
	B5/B14			B5			B14											
44.0	7.5	187	0.88	4.3	480	10.6	415	9.2	1.2	132	112 100	—	132	112 100	90	132	—	—
	10	140	0.87	4.0	504	8.5	446	7.5	1.1									
	15	93	0.84	3.2	543	6.3	475	5.5	1.1									
	20	70	0.83	3.0	623	5.5	623	5.5	1.0									
	25	56	0.81	2.7	578	4.2	554	4	1.0									
	30	47	0.77	2.2	601	3.8	472	3	1.3									
	40	35	0.74	2.0	650	3.2	606	3	1.1	—	90	—	90	—	—	—		
	50	28	0.72	1.8	608	2.5	538	2.2	1.1									
	65	22	0.68	1.6	528	1.8	451	1.5	1.2									
	80	18	0.65	1.5	503	1.4	390	1.1	1.3									
	100	14	0.61	1.3	458	1.1	458	1.1	1.0									

110	<b>n<sub>1</sub> = 900</b>				<b>XA</b>		<b>XC - XF</b>											
	i <sub>n</sub>	n <sub>2</sub> [rpm]	Rd	P <sub>to</sub>	T <sub>2M</sub> [Nm]	P [kW]	T <sub>2</sub> [Nm]	P <sub>1</sub> [kW]	FS'	Input - IEC								
										XC			XF					
	B5/B14			B5			B14											
44.0	7.5	120	0.87	—	578	8.3	381	5.5	1.5	132	112 100	—	132	112 100	90	132	—	—
	10	90	0.86		600	6.6	500	5.5	1.2									
	15	60	0.83		641	4.9	526	4	1.2									
	20	45	0.81		720	4.2	685	4	1.1									
	25	36	0.79		672	3.2	628	3	1.1									
	30	30	0.74		697	2.9	520	2.2	1.3									
	40	23	0.71		749	2.5	664	2.2	1.1	—	90	—	90	—	—	—		
	50	18	0.68		697	1.9	653	1.8	1.1									
	65	14	0.64		603	1.4	487	1.1	1.2									
	80	11	0.61		571	1.1	570	1.1	1.0									
	100	9	0.57		513	0.85	450	0.75	1.1									

110	<b>n<sub>1</sub> = 500</b>				<b>XA</b>		<b>XC - XF</b>											
	i <sub>n</sub>	n <sub>2</sub> [rpm]	Rd	P <sub>to</sub>	T <sub>2M</sub> [Nm]	P [kW]	T <sub>2</sub> [Nm]	P <sub>1</sub> [kW]	FS'	Input - IEC								
										XC			XF					
	B5/B14			B5			B14											
44.0	7.5	67	0.85	—	718	5.9	183	1.5	3.9	132	112 100	—	132	112 100	90	132	—	—
	10	50	0.84		738	4.6	240	1.5	3.1									
	15	33	0.80		778	3.4	344	1.5	2.3									
	20	25	0.78		866	2.9	446	1.5	1.9									
	25	20	0.76		802	2.2	542	1.5	1.5									
	30	17	0.70		832	2.1	603	1.5	1.4									
	40	13	0.67		886	1.7	765	1.5	1.2	—	90	—	90	—	—	—		
	50	10	0.64		820	1.3	671	1.1	1.2									
	65	8	0.59		705	0.96	553	0.75	1.3									
	80	6	0.56		664	0.77	643	0.75	1.0									
	100	5	0.52		594	0.60	542	0.55	1.1									

\* **ATTENZIONE:** la coppia massima utilizzabile [T<sub>2M</sub>] deve essere calcolata utilizzando il fattore di servizio:  
T<sub>2M</sub> = T<sub>2</sub> x FS'

\* **WARNING:** Maximum allowable torque [T<sub>2M</sub>] must be calculated using the following service factor:  
T<sub>2M</sub> = T<sub>2</sub> x FS'

\* **ACHTUNG:** das max. anwendbare Drehmoment [T<sub>2M</sub>] muss mit folgendem Betriebsfaktor berechnet werden:  
T<sub>2M</sub> = T<sub>2</sub> x FS'

**Dati tecnici**
**Technical data**
**Technische Daten**

130	<b>n<sub>1</sub> = 2800</b>				<b>XA</b>		<b>XC - XF</b>									
	i <sub>n</sub>	n <sub>2</sub> [rpm]	Rd	P <sub>to</sub>	T <sub>2M</sub> [Nm]	P [kW]	T <sub>2</sub> [Nm]	P <sub>1</sub> [kW]	FS'	Input - IEC						
										XC			XF			
	B5/B14			B5		B14										
55.0	7.5	373	0.90	—	530	23	345	15	1.5	132	112 100	—	132	112 100	90	—
	10	280	0.89		549	18.1	455	15	1.2							
	15	187	0.87		636	14.3	490	11	1.3							
	20	140	0.86		733	12.5	645	11	1.1							
	25	112	0.85		710	9.8	667	9.2	1.1							
	30	93	0.81		729	8.8	622	7.5	1.2							
	40	70	0.80		819	7.5	819	7.5	1.0							
	50	56	0.78		758	5.7	732	5.5	1.0							
	65	43	0.75		648	3.9	499	3	1.3							
	80	35	0.73		637	3.2	598	3	1.1							
	100	28	0.70		597	2.5	525	2.2	1.1							

130	<b>n<sub>1</sub> = 1400</b>				<b>XA</b>		<b>XC - XF</b>									
	i <sub>n</sub>	n <sub>2</sub> [rpm]	Rd	P <sub>to</sub>	T <sub>2M</sub> [Nm]	P [kW]	T <sub>2</sub> [Nm]	P <sub>1</sub> [kW]	FS'	Input - IEC						
										XC			XF			
	B5/B14			B5		B14										
55.0	7.5	187	0.89	6.0	736	16.2	418	9.2	1.8	132	112 100	—	132	112 100	90	—
	10	140	0.88	5.5	756	12.6	552	9.2	1.4							
	15	93	0.85	4.4	855	9.8	803	9.2	1.1							
	20	70	0.84	4.1	974	8.5	860	7.5	1.1							
	25	56	0.83	3.9	920	6.5	778	5.5	1.2							
	30	47	0.79	3.2	947	5.9	883	5.5	1.1							
	40	35	0.76	2.8	1037	5.0	829	4	1.3							
	50	28	0.74	2.6	959	3.8	757	3	1.3							
	65	22	0.71	2.3	801	2.6	678	2.2	1.2							
	80	18	0.68	2.1	758	2.1	649	1.8	1.2							
	100	14	0.64	1.8	699	1.6	655	1.5	1.1							

130	<b>n<sub>1</sub> = 900</b>				<b>XA</b>		<b>XC - XF</b>									
	i <sub>n</sub>	n <sub>2</sub> [rpm]	Rd	P <sub>to</sub>	T <sub>2M</sub> [Nm]	P [kW]	T <sub>2</sub> [Nm]	P <sub>1</sub> [kW]	FS'	Input - IEC						
										XC			XF			
	B5/B14			B5		B14										
55.0	7.5	120	0.88	—	889	12.7	385	5.5	2.3	132	112 100	—	132	112 100	90	—
	10	90	0.87		905	9.8	508	5.5	1.8							
	15	60	0.84		1016	7.6	735	5.5	1.4							
	20	45	0.82		1149	6.6	957	5.5	1.2							
	25	36	0.81		1074	5.0	860	4	1.3							
	30	30	0.76		1113	4.6	968	4	1.2							
	40	23	0.73		1208	3.9	930	3	1.3							
	50	18	0.70		1077	2.9	817	2.2	1.3							
	65	14	0.67		924	2.0	832	1.8	1.1							
	80	11	0.64		869	1.6	815	1.5	1.1							
	100	9	0.60		828	1.3	700	1.1	1.2							



130	<b>n<sub>1</sub> = 500</b>				<b>XA</b>		<b>XC - XF</b>									
	i <sub>n</sub>	n <sub>2</sub> [rpm]	Rd	P <sub>to</sub>	T <sub>2M</sub> [Nm]	P [kW]	T <sub>2</sub> [Nm]	P <sub>1</sub> [kW]	FS'	Input - IEC						
										XC			XF			
	B5/B14			B5		B14										
55.0	7.5	67	0.86	—	1109	9.0	228	1.85	4.9	132	112 100	—	132	112 100	90	—
	10	50	0.84		1107	6.9	297	1.85	3.7							
	15	33	0.81		1230	5.3	429	1.85	2.9							
	20	25	0.79		1388	4.6	558	1.85	2.5							
	25	20	0.78		1266	3.4	689	1.85	1.8							
	30	17	0.72		1320	3.2	763	1.85	1.7							
	40	13	0.69		1423	2.7	975	1.85	1.5							
	50	10	0.66		1261	2.0	1166	1.85	1.1							
	65	8	0.63		1095	1.4	860	1.10	1.3							
	80	6	0.59		1082	1.2	992	1.10	1.1							
	100	5	0.55		945	0.9	788	0.75	1.2							



**\* ATTENZIONE:** la coppia massima utilizzabile [T<sub>2M</sub>] deve essere calcolata utilizzando il fattore di servizio:  
 $T_{2M} = T_2 \times FS'$



**\* WARNING:** Maximum allowable torque [T<sub>2M</sub>] must be calculated using the following service factor:  
 $T_{2M} = T_2 \times FS'$

**\* ACHTUNG:** das max. anwendbare Drehmoment [T<sub>2M</sub>] muss mit folgendem Betriebsfaktor berechnet werden:  
 $T_{2M} = T_2 \times FS'$

**Momenti d'inerzia**
**Moments of inertia**
**Trägheitsmoment**

X30	$i_n$	XA 	XC 		XF 	
			B5 - B14		B5 - B14	
			IEC 56	IEC 63	IEC 56	IEC 63
5	0.077	0.130	0.127	0.122	0.123	
7.5	0.058	0.112	0.109	0.102	0.103	
10	0.049	0.103	0.100	0.093	0.094	
15	0.042	0.097	0.094	0.087	0.087	
20	0.039	0.095	0.092	0.084	0.084	
25	0.038	0.094	0.091	0.083	0.083	
30	0.038	0.093	0.090	0.083	0.084	
40	0.037	0.093	0.090	0.082	0.082	
50	0.037	0.092	0.089	0.081	0.082	
65	0.024	0.079	-	0.069	0.069	
80	0.024	0.079	-	0.069	0.069	
100	0.024	0.078	-	0.069	0.069	

X40	$i_n$	XA 	XC 			XF 		
			B5 - B14			B5	B5 - B14	
			IEC 56	IEC 63	IEC 71	IEC 56	IEC 63	IEC 71
5	0.242	-	0.391	0.463	0.289	0.447	0.464	
7.5	0.170	-	0.321	0.356	0.217	0.375	0.391	
10	0.144	-	0.272	0.347	0.190	0.348	0.365	
15	0.125	-	0.266	0.340	0.171	0.329	0.346	
20	0.094	-	0.263	0.338	0.141	0.298	0.315	
25	0.091	-	0.262	0.337	0.137	0.295	0.312	
30	0.113	-	0.262	0.337	0.160	0.318	0.335	
40	0.087	-	0.261	-	0.134	0.292	0.309	
50	0.087	0.182	0.261	-	0.133	0.291	0.308	
65	0.069	0.182	0.261	-	0.116	0.274	0.290	
80	0.069	0.182	0.261	-	0.115	0.273	0.290	
100	0.068	0.182	0.261	-	0.115	0.273	0.290	



X50	$i_n$	XA 	XC 			XF 		
			B5 - B14			B5	B5 - B14	
			IEC 63	IEC 71	IEC 80	IEC 63	IEC 71	IEC 80
5	0.744	-	0.922	1.046	0.978	0.955	1.558	
7.5	0.499	-	0.684	0.935	0.733	0.750	1.313	
10	0.417	-	0.602	0.853	0.651	0.668	1.231	
15	0.358	-	0.543	0.794	0.593	0.609	1.173	
20	0.281	-	0.523	0.774	0.516	0.532	1.096	
25	0.272	-	0.513	0.764	0.506	0.523	1.086	
30	0.323	-	0.508	0.759	0.557	0.574	1.137	
40	0.262	0.315	0.503	-	0.496	0.513	1.076	
50	0.183	0.313	0.501	-	0.417	0.434	0.997	
65	0.136	0.311	0.499	-	0.370	0.387	0.950	
80	0.136	0.310	0.498	-	0.370	0.387	0.950	
100	0.135	0.309	0.498	-	0.370	0.386	0.950	



Momenti d'inerzia [kg·cm<sup>2</sup>]  
riferiti all'albero veloce in entrata

Moments of inertia [kg·cm<sup>2</sup>]  
referred to input shaft

Trägheitsmoment [kg·cm<sup>2</sup>]  
bez. Antriebswelle

**Momenti d'inerzia**
**Moments of inertia**
**Trägheitsmoment**

	$i_n$	XA 	XC 			XF 		
			B5 - B14			B5	B5 - B14	
			IEC 71	IEC 80	IEC 90	IEC 71	IEC 80	IEC 90
<b>X63</b>	5	1.853	-	2.431	2.671	2.632	2.766	3.844
	7.5	1.363	-	1.949	2.269	2.142	2.276	3.354
	10	1.158	-	1.744	2.063	1.936	2.070	3.148
	15	1.011	-	1.597	1.916	1.789	1.924	3.001
	20	0.710	-	1.545	1.864	1.489	1.623	2.701
	25	0.679	-	1.514	1.833	1.458	1.592	2.670
	30	0.922	-	1.508	1.828	1.701	1.835	2.913
	40	0.660	0.966	1.495	-	1.439	1.573	2.651
	50	0.653	0.959	1.488	-	1.431	1.565	2.643
	65	0.552	0.955	1.484	-	1.330	1.465	2.542
	80	0.550	0.953	1.482	-	1.329	1.463	2.541
100	0.549	0.952	1.481	-	1.327	1.462	2.539	

	$i_n$	XA 	XC 				XF 		
			B5 - B14				B5	B5 - B14	
			IEC 71	IEC 80	IEC 90	IEC 100-112	IEC 80	IEC 90	IEC 100-112
<b>X75</b>	7.5	2.970	-	-	3.712	4.462	5.138	5.066	6.837
	10	2.492	-	-	3.234	3.984	4.661	4.588	6.359
	15	2.151	-	-	2.893	3.643	4.320	4.247	6.018
	20	1.567	-	-	2.774	3.523	3.735	3.662	5.433
	25	1.501	-	-	2.709	3.458	3.670	3.597	5.368
	30	1.946	1.615	1.575	2.689	3.438	4.115	4.042	5.813
	40	1.451	-	1.573	2.659	-	3.620	3.547	5.318
	50	1.435	-	1.570	2.642	-	3.603	3.531	5.302
	65	1.158	1.609	1.569	2.633	-	3.326	3.253	5.024
	80	1.153	1.605	1.565	2.629	-	3.322	3.249	5.020
	100	1.150	1.602	1.562	2.626	-	3.318	3.246	5.017



	$i_n$		XC 		
			B5 - B14		
			IEC 80	IEC 90	IEC 100-112
<b>X89</b>	7.5			6.898	7.671
	10			5.875	6.648
	15			5.144	5.917
	20			3.398	5.661
	25			3.256	5.520
	30			3.215	5.479
	40			3.151	5.411
	50			3.115	-
	65		2.024	3.096	-
	80		2.014	3.087	-
	100		2.008	3.080	-



 Momenti d'inerzia [kg·cm<sup>2</sup>]  
 riferiti all'albero veloce in entrata



 Moments of inertia [kg·cm<sup>2</sup>]  
 referred to input shaft

 Trägheitsmoment [kg·cm<sup>2</sup>]  
 bez. Antriebswelle

**Momenti d'inerzia**
**Moments of inertia**
**Trägheitsmoment**

	$i_n$	XA 	XC 			XF 		
			B5 - B14			B5	B5 - B14	
			IEC 80	IEC 90	IEC 100-112	IEC 80	IEC 90	IEC 100-112
<b>X90</b>	7.5	6.167	-	6.898	7.671	8.335	8.263	10.033
	10	5.143	-	5.875	6.648	7.312	7.239	9.010
	15	4.413	-	5.144	5.917	6.581	6.508	8.279
	20	2.653	-	3.398	5.661	4.821	4.749	6.519
	25	2.511	-	3.256	5.520	4.680	4.607	6.378
	30	3.974	-	3.215	5.479	6.142	6.070	7.841
	40	2.406	-	3.151	5.411	4.574	4.502	6.273
	50	2.371	-	3.115	-	4.539	4.467	6.237
	65	1.672	2.024	3.096	-	3.841	3.768	5.539
	80	1.663	2.014	3.087	-	3.831	3.759	5.530
100	1.656	2.008	3.080	-	3.825	3.752	5.523	

	$i_n$	XA 	XC 			XF 			
			B5 - B14			B5			B5 - B14
			IEC 90	IEC 100-112	IEC 132	IEC 80	IEC 90	IEC 100-112	IEC 132
<b>X110</b>	7.5	16.247	-	17.980	20.038	20.584	20.535	20.711	22.704
	10	13.386	-	15.119	17.177	17.723	17.674	17.851	19.843
	15	11.343	-	13.076	15.134	15.679	15.631	15.807	17.799
	20	6.655	-	8.367	14.418	10.992	10.943	11.120	13.112
	25	6.257	-	7.969	14.020	10.594	10.545	10.722	12.714
	30	10.117	-	11.850	13.908	14.453	14.405	14.581	16.573
	40	5.965	-	7.677	-	10.302	10.254	10.430	12.422
	50	5.866	-	7.578	-	10.203	10.154	10.330	12.323
	65	3.792	5.592	7.510	-	8.128	8.080	8.256	10.248
	80	3.770	5.570	7.489	-	8.107	8.059	8.235	10.227
100	3.755	5.555	7.474	-	8.092	8.044	8.220	10.212	

	$i_n$	XA 	XC 			XF 		
			B5 - B14			B5		
			IEC 90	IEC 100-112	IEC 132	IEC 90	IEC 100-112	IEC 132
<b>X130</b>	7.5	42.80	-	40.70	42.78	48.92	49.22	50.01
	10	35.06	-	32.96	35.04	41.18	41.48	42.27
	15	29.53	-	27.43	29.51	35.66	35.96	36.74
	20	18.95	-	16.68	27.58	25.07	25.37	26.16
	25	17.80	-	15.52	26.42	23.92	24.22	25.00
	30	26.22	-	24.12	26.20	32.34	32.64	33.42
	40	17.09	-	14.81	25.71	23.21	23.51	24.29
	50	16.80	-	12.57	-	22.92	23.22	24.00
	65	12.53	10.46	14.35	-	18.66	18.96	19.74
	80	12.48	10.41	14.30	-	18.60	18.90	19.68
100	12.44	10.37	14.26	-	18.56	18.86	19.65	

Momenti d'inerzia [kg·cm<sup>2</sup>]  
riferiti all'albero veloce in entrata

Moments of inertia [kg·cm<sup>2</sup>]  
referred to input shaft

Trägheitsmoment [kg·cm<sup>2</sup>]  
bez. Antriebswelle

**Dimensioni**

**Dimensions**

**Abmessungen**

**XA**

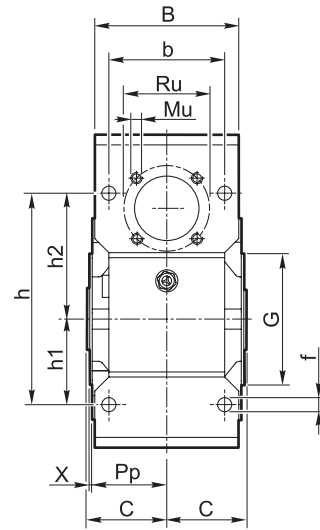
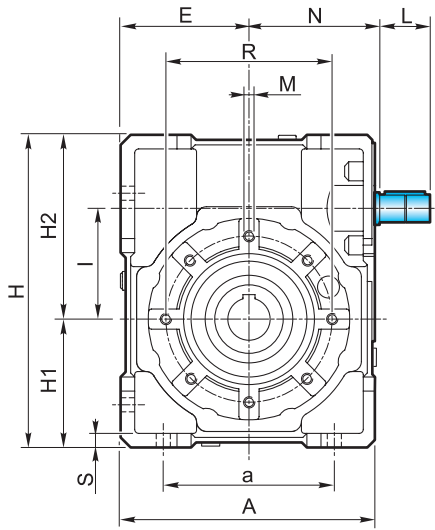

**XF**

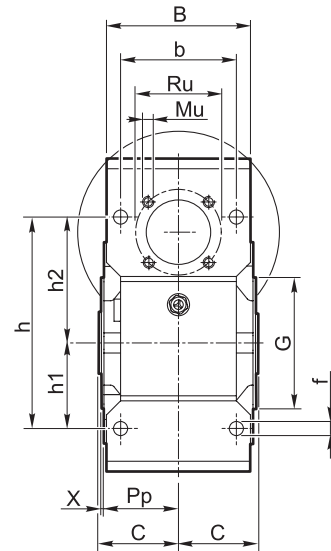
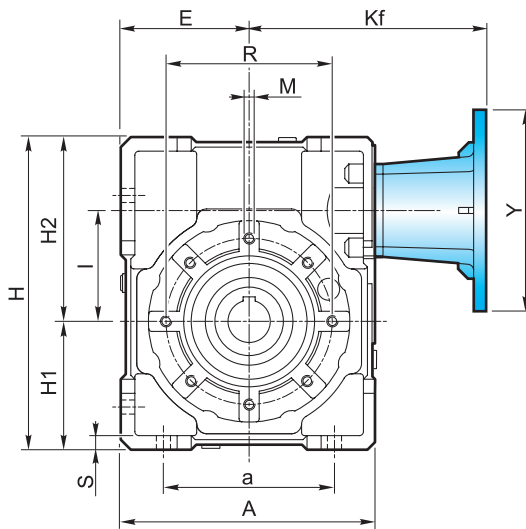

**XC**

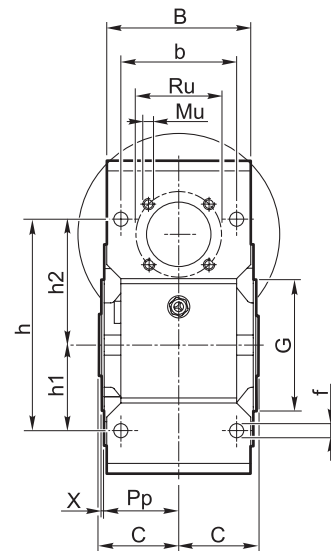
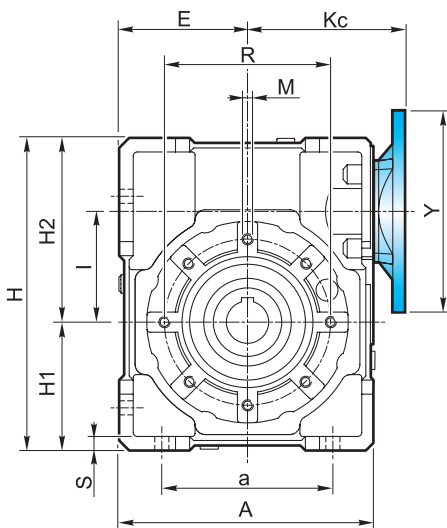

**Dimensioni**

**Dimensions**

**Abmessungen**

Flangia pendolare / Shaft-mounted flange / Aufsteckflansch

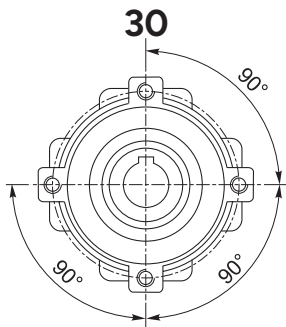

4 Fori / Holes / Bohrungen

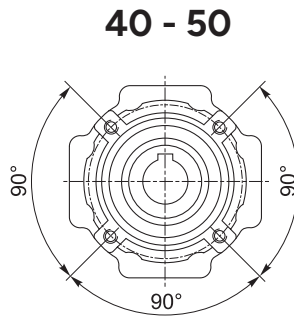

4 Fori / Holes / Bohrungen

63 - 75 - 89 - 90 - 110 - 130

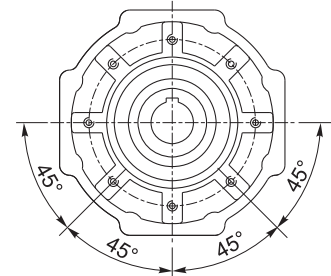

8 Fori / Holes / Bohrungen

Albero uscita cavo  
Output hollow shaft  
Abtriebshohlwelle

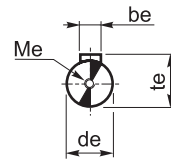
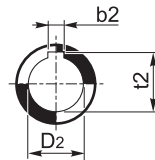

Albero entrata  
Input shaft  
Antriebswelle

X	A	a	B	b	b <sub>e</sub>	b <sub>2</sub>	C	d <sub>e</sub> j <sub>6</sub>	D <sub>2</sub> H <sub>8</sub>	E	f	G h <sub>8</sub>	H	H <sub>1</sub>	H <sub>2</sub>	h	h <sub>1</sub>	h <sub>2</sub>		
30	80	54	56	44	3	5	—	31.5	9	14	—	40	6.5	55	97	40	57	71	27	44
40	105	70	71	60	4	6	6	39	11	18	19	50	6.5	60	125	50	75	90	35	55
50	125	80	85	70	5	8	8	46	14	25	24	60	8.5	70	150	60	90	104	40	64
63	147	100	103	85	6	8	—	56	19	25	—	72	9	80	182	72	110	130	50	80
75	176	120	112	90	8	8	8	60	24	28	30	86	11	95	219.5	86	133.5	153	60	93
89*	203	140	130	100	—	10	10	70	—	35	32	103	13	110	248.5	103	145.5	172	70	102
90	203	140	130	100	8	10	10	70	24	35	32	103	13	110	248.5	103	145.5	172	70	102
110	252.5	170	143	115	8	12	—	77.5	28	42	—	127.5	14	130	310.5	127.5	183	210	85	125
130	292.5	200	155	120	10	14	14	85	38	45	48	147.5	15	180	355	147.5	207.5	240	100	140

X	I	K <sub>c</sub>	K <sub>f</sub>	L	M	M <sub>e</sub>	M <sub>u</sub>	N	P <sub>p</sub>	R	R <sub>u</sub>	S	t <sub>e</sub>	t <sub>2</sub>	X	
30	31.5	57	vedi pag. see page siehe S. B22	15	M6x8	M4x10	M5x7.5	44.5	29	65	35.4	5.5	10.2	16.3	—	1.5
40	40	75		20	M6x10	M4x12	M5x10	57.5	36.5	75	42.4	6	12.5	20.8	21.8	1.5
50	50	82		25	M8x10	M5x13	M6x10	67.5	43.5	85	53.7	7	16	28.3	27.3	1.5
63	63	95		30	M8x14	M8x20	M6x12	77.5	53	95	60.8	8	21.5	28.3	—	2
75	75	112 - 110 <sup>(1)</sup>		40	M8x14	M8x20	M8x12	95	57	115	70.7	10	27	31.3	33.3	2
89*	90	122		—	M10x18	—	M8x14	—	67	130	70.7	12	—	38.3	35.3	2
90	90	122		40	M10x18	M8x20	M8x14	105	67	130	70.7	12	27	38.3	35.3	2
110	110	153		50	M10x18	M8x20	M10x18	130	74	165	85.0	14	31	45.3	—	2.5
130	130	173		70	M12x20	M10x25	M10x16	152	81	215	104	15	41	48.8	51.8	3

\*: 89 solo con tipo di entrata C

\*: 89 only with input type C

\*: 89 nur mit Antriebsart C

(1): Solo per PAM 71B14 / Only for PAM 71B14 / Nur PAM 71B14

**Dimensioni**
**Dimensions**
**Abmessungen**

Flangia uscita / Output flange / Abtriebsflansch

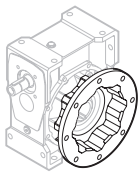
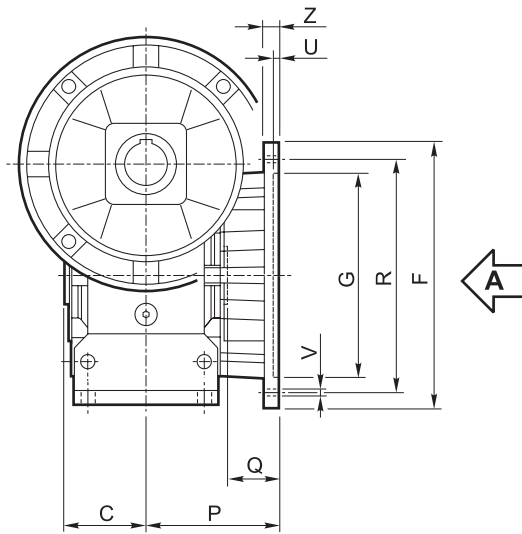
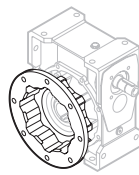
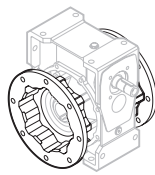
**F...D**  
 Standard

**F...S**

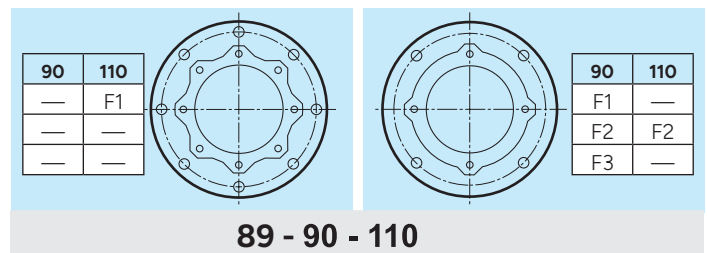
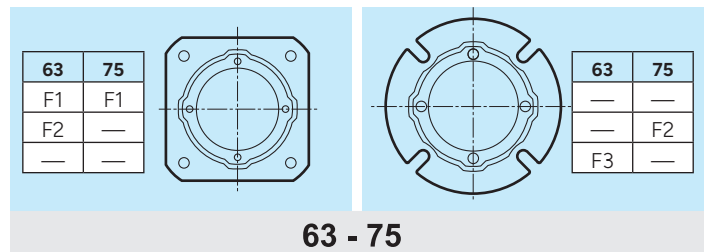
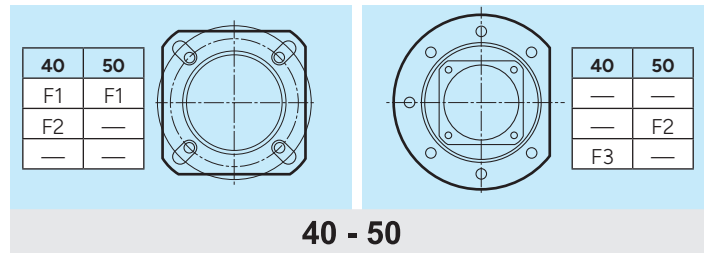
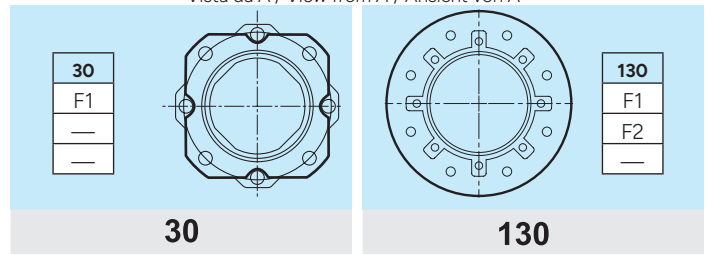
**F...2**

Vista da A / View from A / Ansicht von A



Tipo Type Typ	C	F		G H8	P	Q	R	U	V			Z	
											∅		
<b>30</b>	F1	31.5		66	50	54.5	23	68	4	n° 4	6.5	6	
	F2												
	F3												
<b>40</b>	F1	39		85	60	67	28	75-90	4	n° 4	9	8	
	F2			85	60	97	58	75-90	4	n° 4	9	8	
	F3			140	95	80	41	115	5		n° 7	9	10
<b>50</b>	F1	46		94	70	90	44	85-100	5	n° 4	11	10	
	F2			160	110	89	43	130	5		n° 7	11	11
	F3												
<b>63</b>	F1	56		142	115	82	26	150	5	n° 4	11	11	
	F2			142	115	112	56	150	5	n° 4	11	11	
	F3			160	110	80.5	24.5	130	5	n° 4	11	12	
<b>75</b>	F1	60		160	130	111	51	165	5	n° 4	13	12	
	F2			160	110	90	30	130	6	n° 4	11	13	
	F3												
<b>89 90</b>	F1	70		200	152	111	41	175	5	n° 4	13	12	
	F2			200	152	151	81	175	5	n° 4	13	13	
	F3			200	130	110	40	165	6	n° 4	11	11	
<b>110</b>	F1	77.5		260	170	131	53.5	230	6		n° 8	13	15
	F2			250	180	150	72.5	215	5	n° 4	15	16	
	F3												
<b>130</b>	F1	85		320	180	140	55	255	7		n° 8 *	16	16
	F2			300	230			265					
	F3												

\* Foratura ruotata di 22.5°

\* Drilling turned of 22.5°



\* Durchbohrung 22.5° versetzt

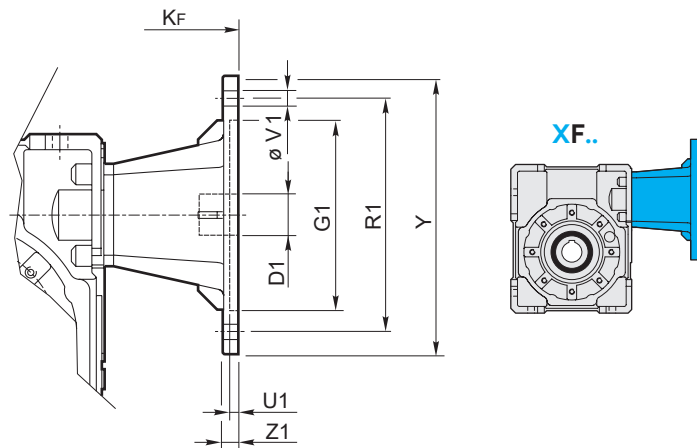
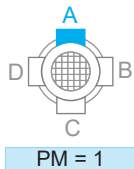

**Dimensioni**
**Dimensions**
**Abmessungen**

Flangia entrata / Input flange / Antriebsflansch



XF	IEC	PM		G <sub>1</sub>	K <sub>F</sub>	R <sub>1</sub>	U <sub>1</sub>	∅	V <sub>1</sub>			Y	Z <sub>1</sub>
		1	2										
30	56 B5	•	•	80	82.5	100	3.5	7		8		120	8
	56 B14		•	50	82.5	65	3.5	6			4	80	8
	63 B5	•	•	95	85.5	115	4	9		8		140	10
	63 B14	•	•	60	85.5	75	3.5	6		8		90	8
40	56 B5	•	•	80	101.5	100	3.5	7		8		120	8
	63 B5	•	•	95	104.5	115	4	9		8		140	10
	63 B14	•	•	60	104.5	75	3.5	6		8		90	8
	71 B5	•	•	110	111.5	130	4.5	9		8		160	10
	71 B14	•	•	70	111.5	85	4	7		8		105	10
50	63 B5	•	•	95	119.5	115	4	9		8		140	10
	71 B5	•	•	110	126.5	130	4.5	9		8		160	10
	71 B14		•	70	126.5	85	3.5	7			4	105	10
	80 B5	•	•	130	136.5	165	4.5	11		8		200	10
	80 B14	•	•	80	136.5	100	4	7		8		120	10
63	71 B5	•	•	110	141.5	130	4.5	9		8		160	10
	80/90 B5	•	•	130	161.5	165	4.5	11		8		200	10
	80 B14	•	•	80	151.5	100	4	7		8		120	10
	90 B14	•	•	95	161.5	115	4	9		8		140	10
75	80/90 B5	•	•	130	190	165	4.5	11		8		200	10
	90 B14		•	95	190	115	4	9			4	140	10
	100/112 B5	•	•	180	200	215	5	14		8		250	14
	100/112 B14	•	•	110	200	130	4.5	9		8		160	10
90	80/90 B5	•	•	130	200	165	4.5	11		8		200	10
	90 B14		•	95	200	115	4	9			4	140	10
	100/112 B5	•	•	180	210	215	5	14		8		250	14
	100/112 B14	•	•	110	210	130	4.5	9		8		160	10
110	80/90 B5	•		130	235	165	4.5	11	4			200	12
	100/112 B5	•		180	245	215	5	14	4			250	14
	132 B5	•		230	266	265	5	14	4			300	16
	132 B14	•		130	266	165	4.5	11	4			200	12
130	90 B5	•		130	281	165	4.5	M10	4			200	12
	100/112 B5	•		180	289	215	5	13	4			250	16
	132 B5	•		230	310	265	5	13	4			300	20

 N.B.: Il montaggio STD di P<sub>M</sub>=2 solo quando non è possibile il montaggio STD di P<sub>M</sub>=1.

 N.B.: STD mounting of P<sub>M</sub>=2 only if STD mounting of P<sub>M</sub>=1 is not possible.

 ANMERKUNG: STD Montage von P<sub>M</sub>=2 nur wenn STD Montage von P<sub>M</sub>=1 unmöglich ist.

## Entrata supplementare (Vite bisorgente)

## Additional input (double extended shaft)

## Zusatzantrieb (beidseitige Welle)

S.e.A.

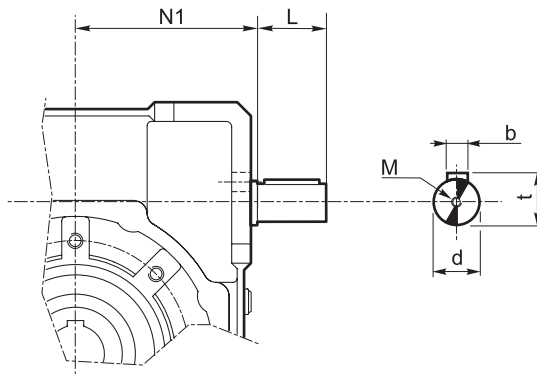

X	d j6	L	M	N1	b	t
30	9	15	M4x10	42.5	3	10.2
40	11	20	M4x12	52.5	4	12.5
50	14	25	M5x13	62.5	5	16
63	19	30	M8x20	74.5	6	21.5
75	24	40	M8x20	91	8	27
89 - 90	24	40	M8x20	108	8	27
110	28	50	M8x20	132.5	8	31
130	38	70	M10x25	152	10	41

## Limitatore di coppia cavo passante

## Torque limiter with through hollow shaft

## Drehmomentbegrenzer mit durchgehender Hohlwelle

Il limitatore di coppia viene consigliato in tutte quelle applicazioni che richiedono una limitazione sulla coppia trasmissibile per proteggere l'impianto e/o preservare il riduttore evitando sovraccarichi o urti indesiderati quanto inaspettati. È un dispositivo con albero dotato di cavo passante, con funzionamento a frizione, ed è integrato al riduttore, presentando un ingombro limitato. Concepito per lavorare a bagno d'olio, il dispositivo risulta affidabile nel tempo ed è esente da usura se non viene mantenuto in condizioni prolungate di slittamento (condizione che si verifica quando la coppia presenta valori superiori a quelli di taratura). La taratura è facilmente regolabile dall'esterno attraverso il serraggio di una ghiera autobloccante che porta a compressione le 4 molle a tazza disposte tra loro in serie.

Il dispositivo non consente:

- l'impiego di cuscinetti a rulli conici in uscita
- funzionamento prolungato in condizioni di slittamento.

Nella tabella seguente vengono riportati i valori delle coppie di slittamento  $M_{25}$  in funzione del n° di giri della ghiera. I valori di taratura presentano una tolleranza del  $\pm 10\%$  e si riferiscono ad una condizione statica. In condizioni dinamiche è da notare che la coppia di slittamento assume valori diversi a seconda del tipo e/o modalità in cui si verifica il sovraccarico: con valori maggiori in caso di carico uniformemente crescente rispetto a valori più contenuti in seguito al verificarsi di picchi improvvisi di carico.

**NOTA:** quando si supera il valore di taratura si ha slittamento.

Il coefficiente di attrito tra le superfici di contatto da statico diventa dinamico e la coppia trasmessa cala del 30% circa. E' quindi opportuno prevedere uno stop per poter ripartire al valore di taratura iniziale.

*The use of a torque limiter is advised when the application requires the limitation of the transmissible torque to safeguard the plant and/or to prevent from unexpected and undesired overloads or shocks which might damage the gearbox.*

*The torque limiter is a device equipped with through hollow shaft and a friction clutch. It is integrated with the gearbox, therefore the space requirement is limited.*

*Designed to work in oil bath, the device is reliable over time and is not subject to wear unless kept under conditions of prolonged slipping (it occurs when the torque values are higher than the calibration values).*

*Calibration can be easily adjusted from outside by tightening the self-locking ring nut which causes the compression of the 4 Belleville washers arranged in series.*

*The device does not go together with:*

- the use of tapered roller bearings at output
- Prolonged operation under slipping conditions.

*The following table shows the values of  $M_{25}$  slipping torques depending on the number of revolutions of the ring nut. Calibration values feature a  $\pm 10\%$  tolerance and refer to static conditions. Under dynamic conditions, the values of the slipping torque differ depending to the type of overload: the values are higher if the load increase is uniform, the values are lower if sudden load peaks occur.*

**NOTE:** Slipping occurs when the setting values are exceeded.

*The friction coefficient between the contact surfaces from static becomes dynamic and the transmitted torque is approx. 30% lower.*

*It is advisable to have a stop first in order to have a restart based on the initial setting value.*

Die Anwendung eines Drehmomentbegrenzers wird empfohlen, um die Anlage und/oder das Getriebe gegen ungewünschte und unerwartete Überbelastungen oder Stößen zu schützen.

Der Begrenzer verfügt über eine Welle mit durchgehender Hohlwelle und eine Kupplung. Er ist in dem Getriebe integriert, d.h. der Raumbedarf ist klein. Der Drehmomentbegrenzer wurde für Betrieb in einem Ölbad entworfen. Er ist zuverlässig über Zeit und verschleissfest (außer wenn Rutschen für lange Zeit besteht: das passiert, wenn das Drehmoment höher als der Eichwert ist). Die Einstellung darf mühelos von außen durch das Anziehen einer selbstsperrenden Mutter ausgeführt werden.

Das Anziehen verursacht die Zusammenrückung der 4 wechelsinniggeschichteten Tellerfeder. Der Begrenzer sieht das folgende nicht vor:

- die Verwendung von Kegelrollenlager am Abtrieb
- Längerer Rutschbetrieb.

Die nachstehende Tabelle zeigt die Werte der Rutschmomente  $M_{25}$  abhängig von der Zahl der Umdrehungen der Mutter. Die Eichwerte weisen  $\pm 10\%$  Toleranz auf und beziehen sich auf statische Bedingungen.

Unter dynamischen Bedingungen hat das Rutschmoment verschiedene Werte je nach Art der Überbelastung. Die Werte sind höher, wenn die Belastung gleichmäßig zunimmt; sie sind niedriger im Falle von plötzlichen Belastungsspitzen.

**BEMERKUNG:** Rutschen tritt auf, wenn die eingestellten Werte überschritten werden. Der Reibungskoeffizient zwischen den Berührungsflächen wird dynamisch anstatt statisch und das übertragene Drehmoment sinkt um ca. 30%. Es ist daher ratsam, vor dem erneuten Anfahren anzuhalten, um die ursprünglichen Drehmomentwerte zu erreichen.

**Limitatore di coppia  
cavo passante**
**Torque limiter with through  
hollow shaft**
**Drehmomentbegrenzer  
mit durchgehender Hohlwelle**

È importante notare che la coppia di slittamento non resta sempre la medesima durante tutta la vita del limitatore.

Tende infatti a diminuire in rapporto al numero e alla durata degli slittamenti che, rodando le superfici di contatto, ne aumentano il rendimento.

È quindi opportuno verificare periodicamente, soprattutto durante la fase di rodaggio, la taratura del dispositivo.

Là dove sia richiesto un errore più contenuto nella taratura, è necessario testare la coppia trasmissibile sull'impianto. Il dispositivo viene consegnato tarato alla coppia riportata a catalogo  $T_{2M}$  salvo diversa indicazione espressa in fase di ordinazione.

*It is important to note that the slipping torque is not the same for the entire life of the torque limiter. It usually decreases in connection with the number and the duration of slippings, this is due to the surface of the torque limiter becoming more engaged, therefore increasing the efficiency.*

*For this reason it is advisable to check the calibration of the device at regular intervals, specially during the running-in period. Should a smaller calibration error be required, it is necessary to test the transmissible torque on the plant. The torque limiter is supplied already calibrated at the torque value  $T_{2M}$ , unless otherwise specified in the order.*

Es ist wichtig zu beachten, dass das Rutschmoment der Rutschkupplung über die gesamte Lebensdauer nicht konstant bleibt, sondern üblicherweise in Verbindung mit längeren Rutschzyklen aufgrund der eingelaufenen Berührungsflächen abnimmt.

Deswegen ist es ratsam, die Einstellung der Vorrichtung besonders während der Einlaufzeit in regelmäßigen Zeitabständen zu prüfen.

Wenn der Drehmomentbegrenzer geliefert wird, ist dieser schon auf dem im Katalog unter  $T_{2M}$  angegebenen Wert eingestellt, außer wenn es in der Bestellung anders angegeben wird.

X	N°. giri della ghiera di regolazione / N°. revolutions of ring nut / Nr. Umdrehungen der Mutter															
	3/4	1	1 1/4	1 1/2	1 3/4	2	2 1/4	2 1/2	2 3/4	3	3 1/4	3 1/2	3 3/4	4	4 1/4	4 1/2
	$M_{2S}$ [Nm]															
30		15	18	22	27	32										
40	23	30	35	40	45	50	60									
50		45	60	70	80	90	100	110								
63			80	90	100	110	120	130	140	150	160	170	180	190	200	
75		140	160	180	200	220	240	260	280	300						
89 - 90						230	280	310	330	350	380	410	435	460	490	510
110		420	500	560	670	730	810	910								
130																

Disposizione delle molle  
Washers' arrangement  
Lage der Feder

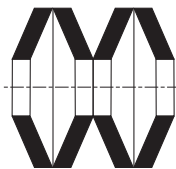

**IN SERIE** (min. coppia, max. sensibilità)  
**SERIES** (min. torque, max sensitivity)  
**SERIE** (min. Moment, max. Empfindlichkeit)

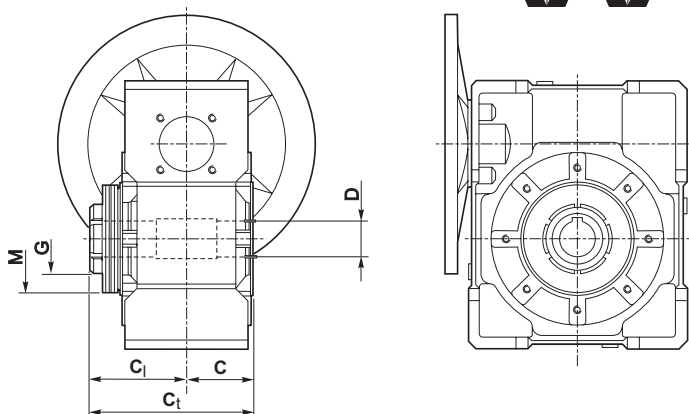

X	C	C <sub>1</sub>	C <sub>2</sub>	D <sub>H8</sub>	M	G
30	31.5	55.5	87	14	50x25.4x1.25	M25x1.5
40	39	65	104	18 (19)	56x30.5x1.5	M30x1.5
50	46	76	122	25 (24)	63x40.5x1.8	M40x1.5
63	56	91	147	25	71x40.5x2	M40x1.5
75	60	100	160	28 (30)	90x50.5x2.5	M50x1.5
89 - 90	70	109	179	35 (32)	100x51x2.7	M50x1.5
110	77.5	127.5	205	42	125x61x4	M60x2.0
130						

( ) A richiesta / On request / Auf Anfrage

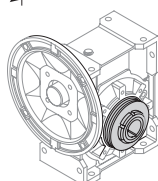

LD

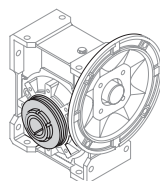

LS

Nella versione con limitatore non è prevista la fornitura degli alberi lenti.

*The version with torque limiter is supplied without output shafts.*

Die Version mit Drehmomentbegrenzer wird ohne Abtriebswellen geliefert.

### Accessori

### Accessories

### Zubehör

#### Albero lento

Albero lento semplice  
Single output shaft  
Standard Abtriebswelle

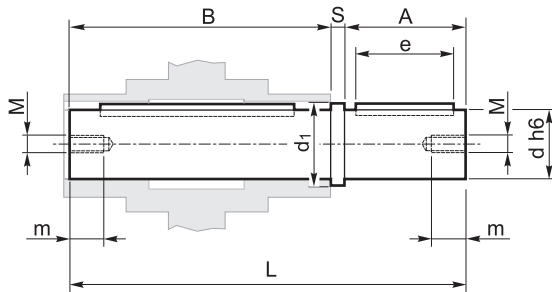

#### Output shaft

#### Abtriebswelle

Albero lento doppio  
Double output shaft  
Doppelte Abtriebswelle

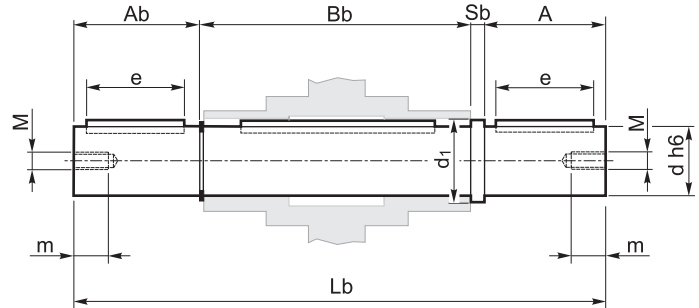

X	A	B	d <sub>h6</sub>	d <sub>1</sub>	e	L	M	m	S
30	30	62	14	18.5	20	94.5	M6	16	2.5
40	40	77	18	19	23.5	120	M6	16	3
50	50	90	25	24	31.5	143.5	M8	22	3.5
63	50	111	25	31.5	40	165	M8	22	4
75	60	119	28	30	34.5	183	M8	22	4
89 - 90	80	139	35	41.5	60	224	M10	28	5
110	80	154.5	42	49.5	60	242.5	M10	28	8
130	80	168	45	54.5	70	253	M16	36	5

A	A <sub>b</sub>	B <sub>b</sub>	d <sub>h6</sub>	d <sub>1</sub>	e	L <sub>b</sub>	S <sub>b</sub>
30	29	64	14	18.5	20	126	2.5
40	39	79	18	23.5	30	161	3
50	49	93	25	31.5	40	195.5	3.5
60	49	113	25	31.5	40	216	4
60	59	121	28	34.5	50	244	4
80	78.5	141.5	35	41.5	60	305	5
80	77.5	157	42	49.5	60	322.5	8
80	78	172	45	54.5	70	335	5

#### Braccio di reazione

#### Torque arm

#### Drehmomentstütze

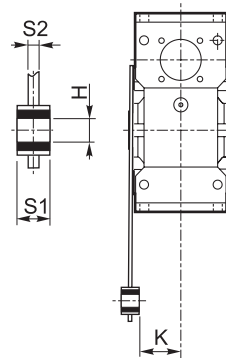
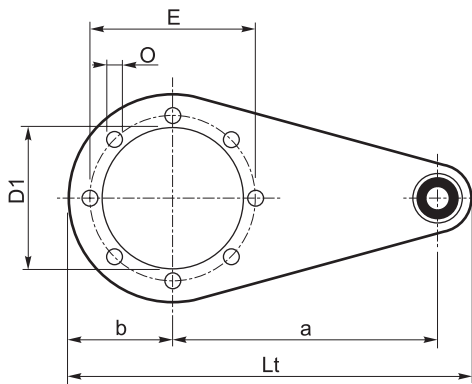

X	a	b	D <sub>1</sub>	E	H	K	L <sub>t</sub>	O	S1	S2
30	85	37.5	55	65	8	24	141.5	7	14	4
40	100	45	60	75	10	31.5	167	7	14	4
50	100	50	70	85	10	39	172	9	14	5
63	150	55	80	95	10	49	227	9	14	6
75	200	70	95	115	20	47.5	302	9	25	6
89 - 90	200	80	110	130	20	57.5	312	11	25	6
110	250	100	130	165	25	62	390	11	30	6
130	250	125	180	215	25	69	415	13	30	6

#### Kit di protezione

#### Protection Kit

#### Schutzvorrichtung

Albero cavo / Hollow shaft / Hohlwelle

Limitatore di coppia / Torque limiter / Drehmomentbegrenzer

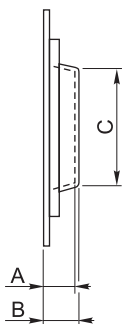

X	A	B	C
30	12	13	39
40	14	15.5	44.5
50	15	16.5	54
63	17	19	60
75	17.5	20	70
89 - 90	21.5	24	80
110	22	25	96
130	22	25	130

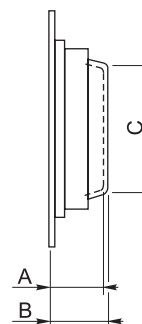

X	A	B	C
30	36	37	36
40	40	41.5	44
50	47	48.5	53
63	52	54	55
75	58	60	68
89 - 90	60.5	63	70
110	72	75	85
130			

#### Opzioni disponibili:

Cuscinetti a rulli conici corona

#### Available options:

Tapered roller bearing on wormgear

#### Auf Anfrage ist folgendes Zubehör erhältlich:

Kegelrollenlager auf Schneckenrad

**XA - XF**

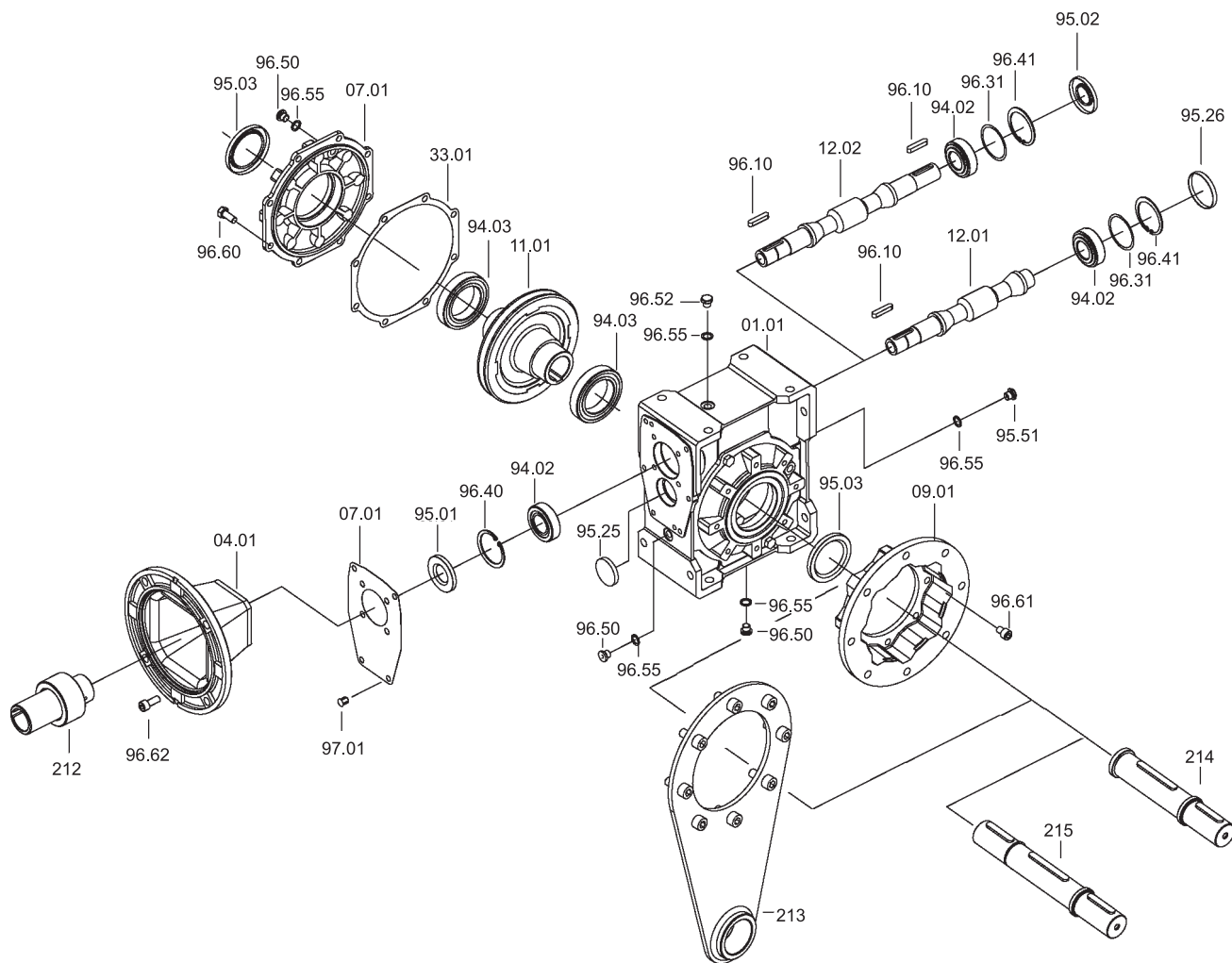

X	Cuscinetti / Bearings / Lager			Anelli di tenuta / Oilseals Öldichtungen			Cappello / Closed oil seal Geschlossene Öldichtung	
	94.02	94.03		95.01	95.02	95.03	95.25	95.26
<b>30</b>	<b>6000</b> 10x26x8	<b>6005</b> 25x47x12	<b>*32005</b> 25x47x15	10/26/5.5	10/26/7	25/40/7	—	ø 26x7
<b>40</b>	<b>6201</b> 12x32x10	<b>6006</b> 30x55x13	<b>*32006</b> 30x55x17	12/32/7	12/32/7	30/47/7	—	ø 32x7
<b>50</b>	<b>6203</b> 17x40x12	<b>6008</b> 40x68x15	<b>*32008</b> 40x68x19	17/40/7	17/40/7	40/62/8	—	ø 40x7
<b>63</b>	<b>30204</b> 20x47x15.25	<b>6008</b> 40x68x15	<b>*32008</b> 40x68x19	20/47/7	20/47/7	40/62/8	—	ø 47x7
<b>75</b>	<b>30205</b> 25x52x16.25	<b>6010</b> 50x80x16	<b>*32010</b> 50x80x20	25/52/7	25/52/7	50/72/8	—	ø 52x7
<b>90</b>	<b>32205</b> 25x52x19.25	<b>6010</b> 50x80x16	<b>*32010</b> 50x80x20	25/52/7	25/52/7	50/72/8	ø 35x5	ø 52x7
<b>110</b>	<b>32206B</b> 30x62x21.25	<b>6012</b> 60x95x18	<b>*32012</b> 60x95x23	30/62/7	30/62/7	60/85/8	ø 47x7	ø 62x7
<b>130</b>	<b>33208</b> 40x80x32	<b>6015</b> 75x115x20	<b>*32015</b> 75x115x25	40/80/10	40/80/10	75/100/10	ø 52x7	ø 80x10

\* Cuscinetti a rulli conici a richiesta - Tapered roller bearings on request - Auf Wunsch Kegelrollenlager

Lista parti di ricambio

Spare parts list

Ersatzteilliste

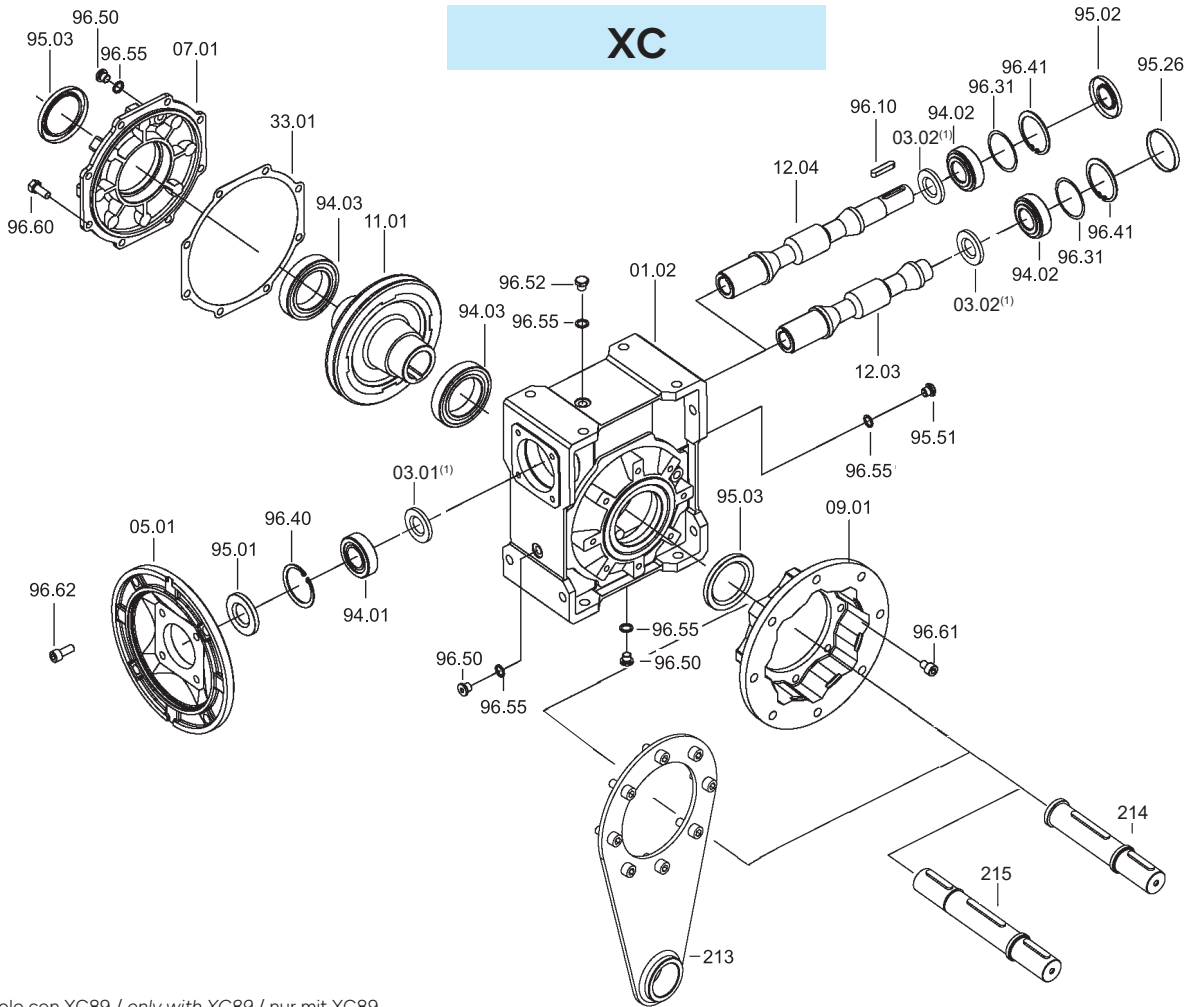

(1): solo con XC89 / only with XC89 / nur mit XC89

X	IEC	Cuscinetti / Bearings / Lager				Anelli di tenuta / Oilseals Öldichtungen			Cappellotto / Closed oil seal Geschlossene Öldichtung
		94.01	94.02	94.03	95.01	95.02	95.03	95.26	
30	56	61804 (20x32x7)	6000	6005	*32005	20/32/5	10/26/7	25/40/7	ø 26x7
	63	61804 (20x32x7)	10x26x8	25x47x12	25x47x15	20/32/5			
40	56	6303 (17x47x14)	6201	6006	*32006	17/47/7	12/32/7	30/47/7	ø 32x7
	63	6204 (20x47x14)				12x32x10			
	71	6005 (25x47x12)				25/47/7			
50	63	6204 (20x47x14)	6203	6008	*32008	20/47/7	17/40/7	40/62/8	ø 40x7
	71	6005 (25x47x12)				17x40x12			
	80	6006 (30x55x13)				30/55/7			
	71	30305 (25x62x18.25)				25/62/7			
63	80	30206 (30x62x17.25)	30204	6008	*32008	30/62/7	20/47/7	40/62/8	ø 47x7
	90	32007 (35x62x18)				20x47x15.25			
	71	30206 (30x62x17.25)				30/62/7			
75	80	30206 (30x62x17.25)	30205	6010	*32010	30/62/7	25/52/7	50/72/8	ø 52x7
	90	32007 (35x62x18)				25x52x16.25			
	100/112	32008 (40x68x19)				40/68/10			
	80	6206 (30x62x16)				30/62/7			
89	90	6007 (35x62x14)	6205 C3	6010	*32010	35/62/7	25/52/7	50/72/8	ø 52x7
	100/112	6008 (40x68x15)				25x52x15			
	80	30206 (30x62x17.25)				30/62/7			
90	90	32007 (35x62x18)	32205B	6010	*32010	35/62/7	25/52/7	50/72/8	ø 52x7
	100/112	32008 (40x68x19)				25x52x19.25			
	90	30208 (40x80x19.75)				40/80/10			
110	100/112	30208 (40x80x19.75)	32206B	6012	*32012	40/80/10	30/62/7	60/85/8	ø 62x7
	132	32010 (50x80x20)				30x62x21.25			
	90	30208 (40x80x19.75)				40/80/10			
130	100/112	30208 (40x80x19.75)	33208	6015	*32015	40/80/10	40/80/10	75/100/10	ø 80x10
	132	32010 (50x80x20)				40x80x32			

\* Cuscinetti a rulli conici a richiesta - Tapered roller bearings on request - Auf Wunsch Kegelrollenlager

## Targhetta

## Plate

## Schild

In fase di ordine delle parti di ricambio, specificare sempre n° particolare (vedi disegno esploso), data (1), n° codice (2) e n° variante (3). (Vedi targhetta).

When ordering please specify the spare part number (see exploded view) as well as the date (1), the article number (2) and the variant number (3). (see plate)

Bei der Bestellung von Ersatzteilen sind Ersatzteilnummer (s. Explosionszeichnung), Datum (1), Artikelnummer (2) und Variantennummer (3) anzugeben. (s. Schild)

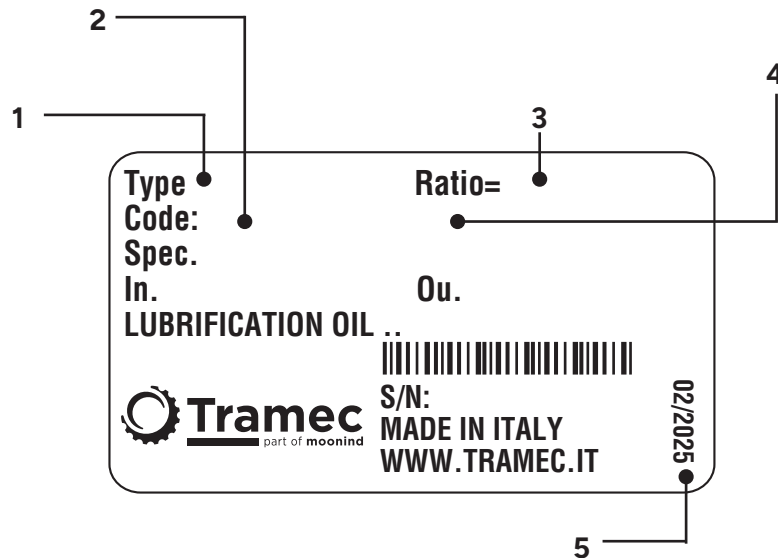

1	TIPO: descrizione	TYPE: description	TYP: Bezeichnung
2	CODICE: distinta base	CODE: base list	ART.-Nr.: Basisstückliste
3	RAP: rapporto di riduzione	RATIO: reduction ratio	ÜBERS: Untersetzungsverhältnis
4	VARIANTE: codice alfanumerico	MODEL: alphanumeric code	VARIANTE: alphanumerische Nummer
5	DATA: mese/anno	DATE: month/year	DATUM: Monat/Jahr

**RIDUTTORI A VITE  
SENZA FINE K**
**K WORM GEARBOXES**
**SCHNECKENGETRIEBE K**
**K**

Caratteristiche	<i>Characteristics</i>	Merkmale	<b>C2</b>
Designazione	<i>Designation</i>	Bezeichnung	<b>C3</b>
Posizioni di montaggio	<i>Mounting position</i>	Einbaulage	<b>C4</b>
Posizione morsettiera	<i>Terminal board position</i>	Lage des Klemmbrett	<b>C4</b>
Lubrificazione	<i>Lubrication</i>	Schmierung	<b>C5</b>
Dati tecnici	<i>Technical data</i>	Technische Daten	<b>C7</b>
Momenti d'inerzia	<i>Moment of inertia</i>	Trägheitsmoment	<b>C16</b>
Dimensioni	<i>Dimensions</i>	Abmessungen	<b>C18</b>
Entrata supplementare	<i>Additional input</i>	Zusatzantrieb	<b>C21</b>
Limitatore di coppia cavo passante	<i>Torque limiter with through hollow shaft</i>	Drehmomentbegrenzer mit durchgehender Hohlwelle	<b>C21</b>
Accessori	<i>Accessories</i>	Zubehör	<b>C23</b>
Lista parti di ricambio	<i>Spare parts list</i>	Ersatzteilliste	<b>C24</b>
Targhetta	<i>Plate</i>	Schild	<b>C25</b>



## Caratteristiche

- I riduttori della serie a vite senza fine KC si presentano estremamente leggeri grazie alla forma compatta della carcassa in ghisa nelle grandezze 90, 110 e 130, in alluminio pressofuso per le grandezze 30, 40, 50, 63, 75 e 89.
- La serie presenta una svariata possibilità di versioni, con e senza piedi, che la rendono più versatile nell'impiego in ogni tipologia di applicazione.
- La serie K è disponibile esclusivamente nella versione predisposta per attacco motore (PAM) e non con albero entrata maschio.
- La vite senza fine è in acciaio legato cementato-temprato ed è rettificata.
- La corona ha il mozzo in ghisa con riporto di fusione dell'anello in bronzo.
- Le carcasce in ghisa sono verniciate BLU RAL5010 mentre quelle in alluminio sono sabbiate.
- Viene fornito l'albero uscita cavo di serie ed esiste un'ampia disponibilità di accessori: seconda entrata, cuscinetti conici sulla corona, flangia uscita, albero lento con 1 o 2 sporgenze, limitatore di coppia con cavo passante, braccio di reazione, kit protezione albero cavo, kit protezione limitatore di coppia.





## Characteristics

- *The KC worm gearboxes are extremely light thanks to the compact shape of the housing, which is in cast iron for sizes 90, 110 and 130, in die-cast aluminium for sizes 30, 40, 50, 63, 75 and 89.*
- *This series features a wide range of versions, with and without feet, which makes it extremely versatile for utilization in various applications.*
- *The K series is available for motor mounting version (PAM) only and not with the male input shaft.*
- *The worm shaft is in case-and quenchhardened alloy steel and ground.*
- *The worm wheel has a cast-iron hub with inserted cast bronze ring.*
- *The cast-iron housings are painted BLUE RAL5010 whereas the aluminium housings are sandblasted.*
- *The hollow output shaft is supplied as standard. A broad range of accessories is available: second input, tapered roller bearings on the worm wheel, output flange, single or double-extended output shaft, torque limiter with through hollow shaft, torque limiter protection kit.*

## Merkmale

- Die Schneckengetriebe der Serie KC sind äußerst leicht dank der kompakten Form des Gehäuses. Das Gehäuse ist aus Gusseisen für Größen 90, 110 und 130, aus Druckgussaluminium für Größen 30, 40, 50, 63, 75 und 89.
- Diese Serie ist in vielen Ausführungen, mit und ohne Füße erhältlich, was eine vielseitige Anwendbarkeit in unterschiedlichsten Applikationen ermöglicht.
- Die Serie K ist nur mit Motoranbau Version (IEC) und nicht mit einer Antriebswelle verfügbar.
- Die Schneckenwelle ist aus einsatzgehärtetem / abgeschrecktem und daraufhin geschliffenem Legierungsstahl.
- Das Schneckenrad besteht aus einer Nabe aus Gusseisen und einem aufgeschleuderten Gussbronze-Ring.
- Gehäuse aus Gusseisen werden mit BLAU RAL5010 lackiert, die Gehäuse aus Aluminium werden sandgestrahlt.
- Die Hohlwelle gehört zur serienmäßigen Ausstattung. Eine breite Auswahl an Zubehör ist erhältlich: zweiter Antrieb, Kegellager auf das Schneckenrad, Abtriebsflansch, Standard oder doppelseitig herausragende Abtriebswelle, Drehmomentbegrenzer mit durchgehender Hohlwelle, Drehmomentstütze, Schutzvorrichtung für Hohlwelle, Schutzvorrichtung für Drehmomentbegrenzer.

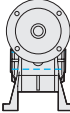
**Designazione**
**Designation**
**Bezeichnung**

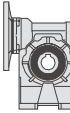
Riduttore Gearbox Getriebe	Tipo entrata Input type Antriebsart	Grandezza Size Größe	Versione Version Ausführung	Rapporto rid. Ratio Untersetzung	Predispos.att. mot. Motor coupling Motorschluss	Albero uscita cavo Hollow output shaft Abtriebshohlwelle	Limitatore di coppia. Torque limiter Drehmoment- begrenzer	Flangia uscita Output flange Abtriebsflansch	Seconda entrata Additional input Zusatzantrieb	Posizione di mont. Mounting position Einbaulage
<b>K</b>	<b>C</b>	<b>50</b>	<b>A1</b>	<b>10</b>	<b>P.A.M</b>	<b>H25</b>	<b>LD</b>	<b>F1S</b>	<b>SeA</b>	<b>B3</b>
Riduttore a vite senza fine Wormgearbox Schneckengetriebe		30 40 50 63 75 89   Alluminio Aluminium Aluminium  90 110 130   Ghisa Cast iron Gusseisen	A1-A2 B1-B2 V1-V2  P	5 7.5 10 15 20 25 30 40 50 65 80 100	56 63 71 80 90 100 112 132	vedi tabelle  see tables  siehe Tabellen  	 LS   LD	F1S-F2S F3S F1D-F2D F3D   SeA	B3 B6 B7 B8 V5 V6	

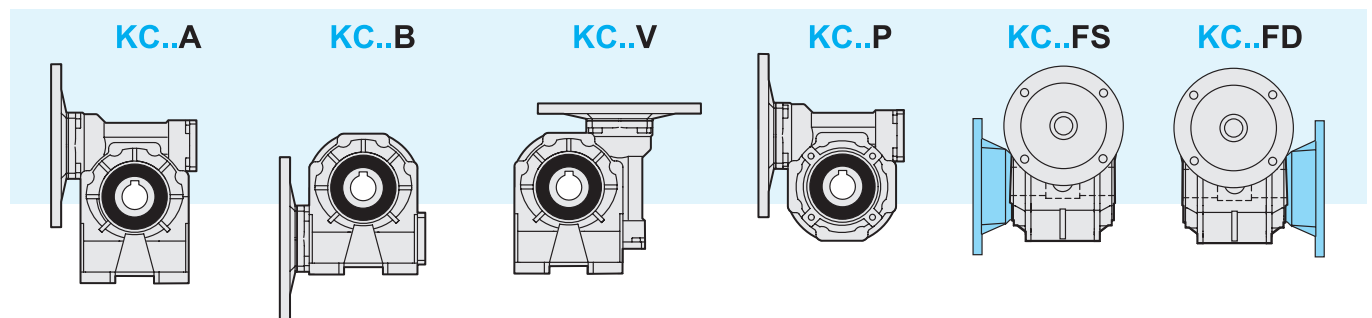
**Versioni**
**Versions**
**Ausführungen**

**Posizioni di montaggio**

**Mounting positions**

**Montageposition**

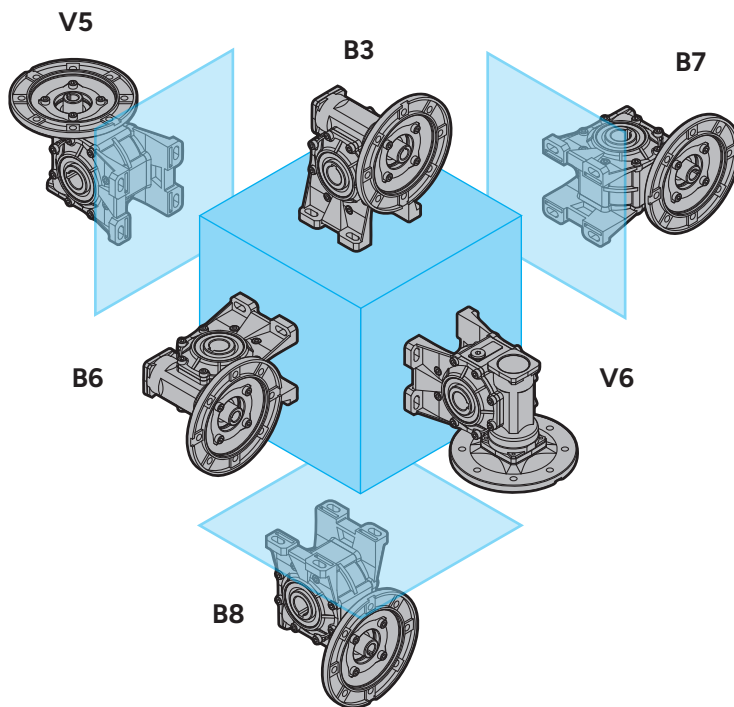

Lo schema rappresentato è da considerarsi valido anche per le altre versioni costruttive.

The diagram shown is also valid for other construction versions.

Das dargestellte Diagramm ist auch für andere Bauvarianten gültig.

**Posizione morsettiera**

**Terminal board position**

**Lage des Klemmenkastens**

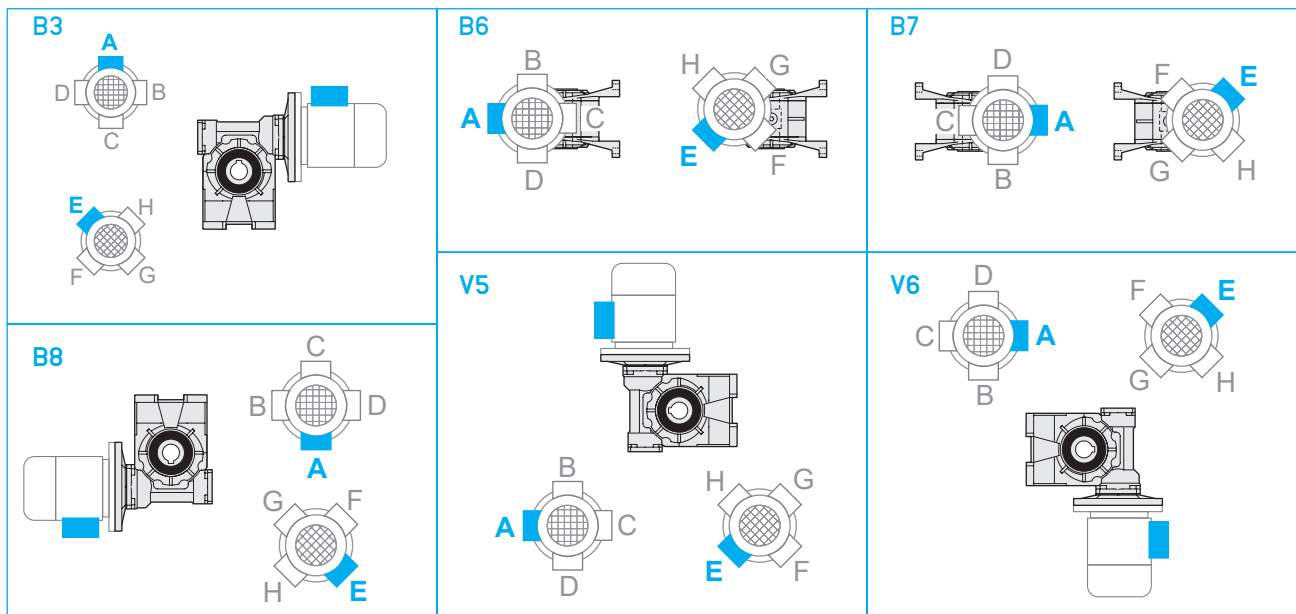

Specificare sempre in fase di ordinazione la posizione di montaggio e la forma costruttiva.  
Posizione morsettiera v. pag. C20 (PM=1; PM=2)

Mounting position always to be specified when ordering.  
Terminal board position see page C20 (PM=1; PM=2)

Bei der Bestellung immer die gewünschte Montageposition und Bauform angeben.  
Lage der Klemmenkaste Seite C20 (PM=1; PM=2)

## Lubrificazione

I riduttori a vite senza fine serie K, tranne la grandezza 130, sono forniti completi di lubrificante sintetico a base PAG con indice di viscosità ISO VG320.

Si raccomanda di precisare sempre, in fase di ordine, la posizione di montaggio desiderata.

Per ulteriori dettagli consultare pag. A19 paragrafo "Lubrificazione".

## Lubrication

KC worm gearboxes, except for the size 130, are supplied with PAG synthetic lubricant featuring an ISO VG320 viscosity class.

Mounting position always to be specified when ordering.

For more details, see page A19, paragraph "Lubrication".

## Schmierung

Schneckengetriebe der Serie KC, außer Größe 130, werden mit synthetischem Schmiermittel auf PAG Basis und Viskosität Index ISO VG320 geliefert. Im Auftrag bitte immer die gewünschte Einbaulage angeben.

Weitere Einzelheiten finden Sie auf Seite A19, Absatz Schmierung.

## Posizione dei tappi e quantità di lubrificante (litri)

F,P

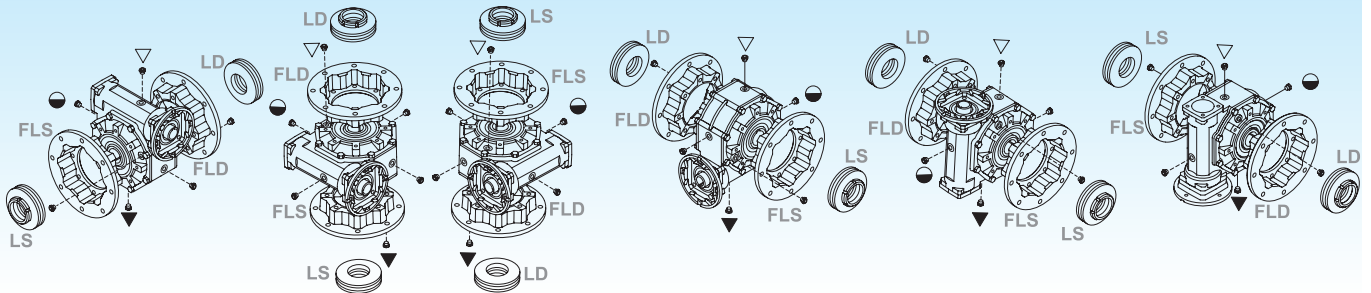

A

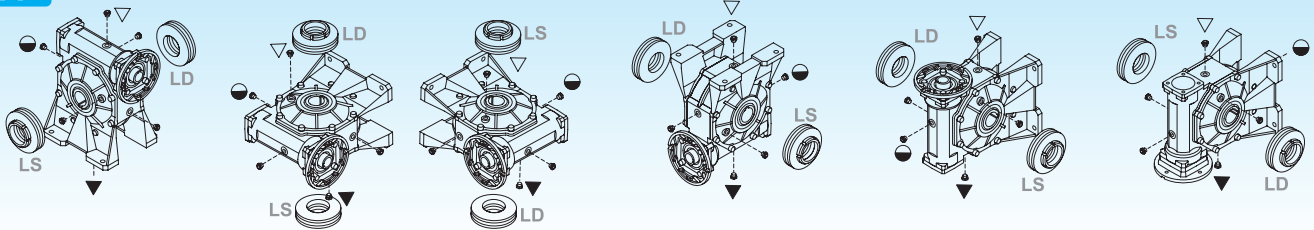

V

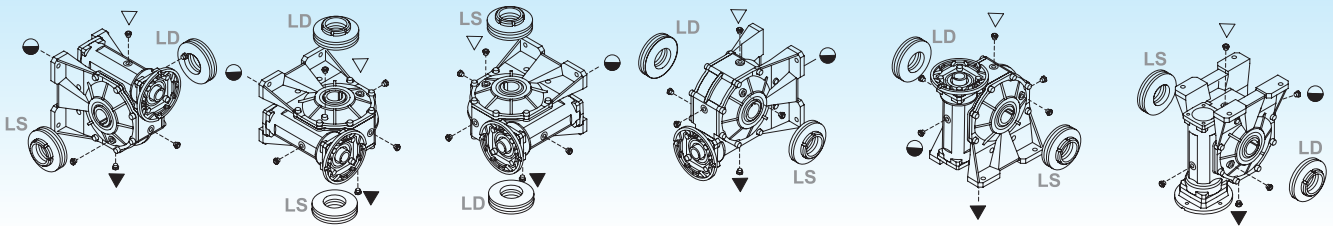

B

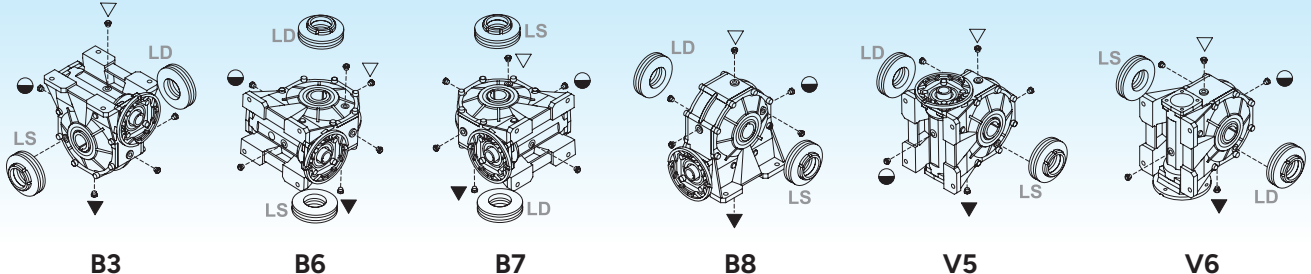

B3

B6

B7

B8

V5

V6

- ▽ Carico e sfiato / Filling and breather  
Einfüll und Entlüftung
- Livello / Level / Ölstand
- ▼ Scarico / Drain / Ablass

Nei corpi in alluminio 30, 40, 50, 63, 75 e 89 è presente un solo tappo di riempimento olio.

Aluminium housings size 30, 40, 50, 63,75 and 89 have one filling plug only.

Gehäuse aus Aluminium Größe 30, 40, 50, 63, 75 und 89 verfügen über nur eine Einfüllschraube.

		<b>Q.tà olio / Oil quantity / Schmiermittelmenge [lt]</b>			
		Posizione di montaggio / <i>Mounting position</i> / Einbaulage			
		<b>B3</b>	<b>B6 - B7</b>	<b>B8</b>	<b>V5 - V6</b>
<b>KC</b>	<b>30</b>	0.015	0.030	0.015	
	<b>40</b>	0.040	0.060	0.040	
	<b>50</b>	0.080	0.120	0.080	
	<b>63</b>	0.160	0.220	0.160	
	<b>75</b>	0.260	0.340	0.260	
	<b>89</b>	0.600	0.700	0.600	
	<b>90</b>	1	0.8	0.8	1.3
	<b>110</b>	2	1.5	2	2
	<b>130</b>	3	2.6	2.1	2.8

**Dati tecnici**
**Technical data**
**Technische Daten**

30	$n_1 = 2800$				KC				Input - IEC B5/B14	
	$i_n$	$n_2$ [rpm]	Rd	$P_{to}$	$T_2$ [Nm]	$P_1$ [kW]	FS'			
	 1.2	5	560	0.89	—	5.6	<b>0.37</b>	2.5	63	56
7.5		373	0.86	8		<b>0.37</b>	2.0			
10		280	0.84	11		<b>0.37</b>	1.5			
15		187	0.81	15		<b>0.37</b>	1.1			
20		140	0.76	13		<b>0.25</b>	1.2			
25		112	0.74	16		<b>0.25</b>	1.0			
30		93	0.71	13		<b>0.18</b>	1.0			
40		70	0.65	16		<b>0.18</b>	1.0			
50		56	0.62	14		<b>0.13</b>	1.1			
65		43	0.57	17		<b>0.13</b>	1.0			
80		35	0.54	13		<b>0.09</b>	1.0			
100		28	0.52	16		<b>0.09</b>	0.8			
								—		

30	$n_1 = 1400$				KC				Input - IEC B5/B14	
	$i_n$	$n_2$ [rpm]	Rd	$P_{to}$	$T_2$ [Nm]	$P_1$ [kW]	FS'			
	 1.2	5	280	0.87	0.40	6.5	<b>0.22</b>	2.9	63	56
7.5		187	0.84	0.40	9	<b>0.22</b>	2.2			
10		140	0.82	0.40	12	<b>0.22</b>	1.8			
15		93	0.77	0.30	17	<b>0.22</b>	1.3			
20		70	0.72	0.20	18	<b>0.18</b>	1.1			
25		56	0.69	0.20	21	<b>0.18</b>	1.0			
30		47	0.66	0.20	18	<b>0.13</b>	1.1			
40		35	0.59	0.20	21	<b>0.13</b>	1.0			
50		28	0.55	0.20	17	<b>0.09</b>	1.1			
65		22	0.51	0.10	20	<b>0.09</b>	1.0			
80		18	0.48	0.10	16	<b>0.06</b>	1.0			
100		14	0.45	0.10	18	<b>0.06</b>	0.8			
								—		

30	$n_1 = 900$				KC				Input - IEC B5/B14	
	$i_n$	$n_2$ [rpm]	Rd	$P_{to}$	$T_2$ [Nm]	$P_1$ [kW]	FS'			
	 1.2	5	180	0.85	—	5.9	<b>0.13</b>	3.9	63	56
7.5		120	0.82	9		<b>0.13</b>	2.9			
10		90	0.80	11		<b>0.13</b>	2.3			
15		60	0.75	15		<b>0.13</b>	1.6			
20		45	0.69	19		<b>0.13</b>	1.2			
25		36	0.66	23		<b>0.13</b>	1.1			
30		30	0.63	18		<b>0.09</b>	1.2			
40		23	0.55	21		<b>0.09</b>	1.1			
50		18	0.52	16		<b>0.06</b>	1.3			
65		14	0.48	20		<b>0.06</b>	1.1			
80		11	0.44	11		<b>0.03</b>	1.7			
100		9	0.42	13		<b>0.03</b>	1.1			
								—		

30	$n_1 = 500$				KC				Input - IEC B5/B14	
	$i_n$	$n_2$ [rpm]	Rd	$P_{to}$	$T_2$ [Nm]	$P_1$ [kW]	FS'			
	 1.2	5	100	0.83	—	—	—	—	63	56
7.5		67	0.80	—		—	—			
10		50	0.77	—		—	—			
15		33	0.72	—		—	—			
20		25	0.66	—		—	—			
25		20	0.62	—		—	—			
30		17	0.59	—		—	—			
40		13	0.51	—		—	—			
50		10	0.48	—		—	—			
65		8	0.43	—		—	—			
80		6	0.40	—		—	—			
100		5	0.38	—		—	—			
								—		

**\* ATTENZIONE:** la coppia massima utilizzabile  $[T_{2M}]$  deve essere calcolata utilizzando il fattore di servizio:  
 $T_{2M} = T_2 \times FS'$

**\* WARNING:** Maximum allowable torque  $[T_{2M}]$  must be calculated using the following service factor:  
 $T_{2M} = T_2 \times FS'$

**\* ACHTUNG:** das max. anwendbare Drehmoment  $[T_{2M}]$  muss mit folgendem Betriebsfaktor berechnet werden:  
 $T_{2M} = T_2 \times FS'$

**Dati tecnici**
**Technical data**
**Technische Daten**

40	$n_1 = 2800$				KC					
	$i_n$	$n_2$ [rpm]	Rd	$P_{t0}$	$T_2$ [Nm]	$P_1$ [kW]	FS'	Input - IEC B5/B14		
	5	560	0.88	—	11.3	<b>0.75</b>	2.2	71	63	—
7.5	373	0.87	17		<b>0.75</b>	1.8				
10	280	0.86	22		<b>0.75</b>	1.4				
15	187	0.82	32		<b>0.75</b>	1.0				
20	140	0.80	30		<b>0.55</b>	1.0				
25	112	0.76	24		<b>0.37</b>	1.1				
30	93	0.73	28		<b>0.37</b>	1.3				
40	70	0.70	24		<b>0.25</b>	1.4				
50	56	0.65	28		<b>0.25</b>	1.1				
65	43	0.61	24		<b>0.18</b>	1.2				
80	35	0.58	21		<b>0.13</b>	1.3				
100	28	0.55	24		<b>0.13</b>	1.0				
 2.0										56

40	$n_1 = 1400$				KC					
	$i_n$	$n_2$ [rpm]	Rd	$P_{t0}$	$T_2$ [Nm]	$P_1$ [kW]	FS'	Input - IEC B5/B14		
	5	280	0.87	0.80	16.3	<b>0.55</b>	2.1	71	63	—
7.5	187	0.85	0.80	24	<b>0.55</b>	1.7				
10	140	0.83	0.70	31	<b>0.55</b>	1.3				
15	93	0.79	0.50	30	<b>0.37</b>	1.4				
20	70	0.76	0.50	38	<b>0.37</b>	1.0				
25	56	0.72	0.40	31	<b>0.25</b>	1.1				
30	47	0.68	0.40	35	<b>0.25</b>	1.2				
40	35	0.64	0.30	38	<b>0.22</b>	1.0				
50	28	0.59	0.30	36	<b>0.18</b>	1.1				
65	22	0.54	0.20	31	<b>0.13</b>	1.1				
80	18	0.52	0.20	31	<b>0.11</b>	1.1				
100	14	0.49	0.20	30	<b>0.09</b>	0.9				
 2.0										56

40	$n_1 = 900$				KC					
	$i_n$	$n_2$ [rpm]	Rd	$P_{t0}$	$T_2$ [Nm]	$P_1$ [kW]	FS'	Input - IEC B5/B14		
	5	180	0.85	—	16.7	<b>0.37</b>	2.5	71	63	—
7.5	120	0.83	25		<b>0.37</b>	2.0				
10	90	0.81	32		<b>0.37</b>	1.5				
15	60	0.76	45		<b>0.37</b>	1.1				
20	45	0.74	39		<b>0.25</b>	1.2				
25	36	0.69	33		<b>0.18</b>	1.3				
30	30	0.65	37		<b>0.18</b>	1.3				
40	23	0.61	33		<b>0.13</b>	1.3				
50	18	0.55	38		<b>0.13</b>	1.1				
65	14	0.51	32		<b>0.09</b>	1.2				
80	11	0.48	37		<b>0.09</b>	1.0				
100	9	0.45	29		<b>0.06</b>	1.0				
 2.0										56

40	$n_1 = 500$				KC					
	$i_n$	$n_2$ [rpm]	Rd	$P_{t0}$	$T_2$ [Nm]	$P_1$ [kW]	FS'	Input - IEC B5/B14		
	5	100	0.83	—	7.1	<b>0.09</b>	7.1	71	63	—
7.5	67	0.81	10		<b>0.09</b>	5.5				
10	50	0.79	14		<b>0.09</b>	4.4				
15	33	0.73	19		<b>0.09</b>	3.1				
20	25	0.70	24		<b>0.09</b>	2.3				
25	20	0.65	28		<b>0.09</b>	1.7				
30	17	0.61	31		<b>0.09</b>	1.8				
40	13	0.57	39		<b>0.09</b>	1.3				
50	10	0.51	44		<b>0.09</b>	1.2				
65	8	0.46	52		<b>0.09</b>	0.9				
80	6	0.44	61*		<b>0.09</b>	0.7*				
100	5	0.41	71*		<b>0.09</b>	0.4*				
 2.0										56

**\* ATTENZIONE:** la coppia massima utilizzabile [ $T_{2M}$ ] deve essere calcolata utilizzando il fattore di servizio:  
 $T_{2M} = T_2 \times FS'$

**\* WARNING:** Maximum allowable torque [ $T_{2M}$ ] must be calculated using the following service factor:  
 $T_{2M} = T_2 \times FS'$

**\* ACHTUNG:** das max. anwendbare Drehmoment [ $T_{2M}$ ] muss mit folgendem Betriebsfaktor berechnet werden:  
 $T_{2M} = T_2 \times FS'$

**Dati tecnici**
**Technical data**
**Technische Daten**

50	$n_1 = 2800$				KC					
	$i_n$	$n_2$ [rpm]	Rd	$P_{t0}$	$T_2$ [Nm]	$P_1$ [kW]	FS'	Input - IEC B5/B14		
	5	560	0.89	—	22.8	1.5	1.9	80	71	—
7.5	373	0.88	34		1.5	1.5				
10	280	0.86	44		1.5	1.2				
15	187	0.84	47		1.1	1.2				
20	140	0.81	42		0.75	1.4				
25	112	0.78	50		0.75	1.0				
30	93	0.75	42		0.55	1.3				
40	70	0.72	54		0.55	1.0				
50	56	0.68	43		0.37	1.3				
65	43	0.64	53		0.37	1.0				
80	35	0.61	41		0.25	1.2				
100	28	0.58	35		0.18	1.3	—	63		

 3.4

50	$n_1 = 1400$				KC					
	$i_n$	$n_2$ [rpm]	Rd	$P_{t0}$	$T_2$ [Nm]	$P_1$ [kW]	FS'	Input - IEC B5/B14		
	5	280	0.87	1.2	26.7	0.9	2.3	80	71	—
7.5	187	0.86	1.2	40	0.9	1.8				
10	140	0.84	1.0	52	0.9	1.4				
15	93	0.80	0.80	74	0.9	1.0				
20	70	0.78	0.70	58	0.55	1.3				
25	56	0.74	0.60	47	0.37	1.4				
30	47	0.71	0.60	53	0.37	1.2				
40	35	0.67	0.50	68	0.37	1.0				
50	28	0.62	0.40	53	0.25	1.3	—	63		
65	22	0.58	0.40	64	0.25	1.0				
80	18	0.54	0.40	53	0.18	1.1				
100	14	0.51	0.30	45	0.13	1.2				

 3.4

50	$n_1 = 900$				KC					
	$i_n$	$n_2$ [rpm]	Rd	$P_{t0}$	$T_2$ [Nm]	$P_1$ [kW]	FS'	Input - IEC B5/B14		
	5	180	0.85	—	33.8	0.75	2.2	80	71	—
7.5	120	0.84	50		0.75	1.6				
10	90	0.82	66		0.75	1.3				
15	60	0.78	68		0.55	1.3				
20	45	0.75	59		0.37	1.5				
25	36	0.71	70		0.37	1.1				
30	30	0.67	79		0.37	1.0				
40	23	0.63	67		0.25	1.1				
50	18	0.59	78		0.25	1.0				
65	14	0.54	67		0.18	1.1				
80	11	0.51	56		0.13	1.2				
100	9	0.47	45		0.09	1.3	—	63		

 3.4

50	$n_1 = 500$				KC					
	$i_n$	$n_2$ [rpm]	Rd	$P_{t0}$	$T_2$ [Nm]	$P_1$ [kW]	FS'	Input - IEC B5/B14		
	5	100	0.84	—	14.3	0.18	6.4	80	71	—
7.5	67	0.82	21		0.18	4.7				
10	50	0.80	28		0.18	3.8				
15	33	0.75	39		0.18	2.7				
20	25	0.72	50		0.18	2.1				
25	20	0.68	58		0.18	1.5				
30	17	0.63	65		0.18	1.5				
40	13	0.59	81		0.18	1.2				
50	10	0.54	93		0.18	1.0				
65	8	0.50	56		0.09	1.5				
80	6	0.46	63		0.09	1.2				
100	5	0.43	74		0.09	0.8	—	63		

 3.4

**\* ATTENZIONE:** la coppia massima utilizzabile  $[T_{2M}]$  deve essere calcolata utilizzando il fattore di servizio:  
 $T_{2M} = T_2 \times FS'$

**\* WARNING:** Maximum allowable torque  $[T_{2M}]$  must be calculated using the following service factor:  
 $T_{2M} = T_2 \times FS'$

**\* ACHTUNG:** das max. anwendbare Drehmoment  $[T_{2M}]$  muss mit folgendem Betriebsfaktor berechnet werden:  
 $T_{2M} = T_2 \times FS'$

**Dati tecnici**
**Technical data**
**Technische Daten**

63	$n_1 = 2800$				KC					
	$i_n$	$n_2$ [rpm]	Rd	$P_{t0}$	$T_2$ [Nm]	$P_1$ [kW]	FS'	Input - IEC B5/B14		
	5	560	0.89	—	45.5	3	1.7	90	80	—
7.5	373	0.88	68		3	1.3				
10	280	0.87	89		3	1.1				
15	187	0.84	95		2.2	1.0				
20	140	0.83	85		1.5	1.3				
25	112	0.81	76		1.1	1.2				
30	93	0.77	87		1.1	1.3				
40	70	0.74	111		1.1	1.1				
50	56	0.70	90		0.75	1.1	—	71		
65	43	0.67	81		0.55	1.2				
80	35	0.64	65		0.37	1.4				
100	28	0.60	75		0.37	1.1				

63	$n_1 = 1400$				KC					
	$i_n$	$n_2$ [rpm]	Rd	$P_{t0}$	$T_2$ [Nm]	$P_1$ [kW]	FS'	Input - IEC B5/B14		
	5	280	0.88	1.8	54	1.8	2.0	90	80	—
7.5	187	0.87	1.8	80	1.8	1.5				
10	140	0.85	1.6	105	1.8	1.2				
15	93	0.81	1.2	125	1.5	1.1				
20	70	0.80	1.2	120	1.1	1.2				
25	56	0.77	1.0	118	0.9	1.0				
30	47	0.73	0.90	134	0.9	1.1				
40	35	0.69	0.80	142	0.75	1.1	—	71		
50	28	0.65	0.70	122	0.55	1.0				
65	22	0.61	0.60	100	0.37	1.2				
80	18	0.58	0.60	79	0.25	1.4				
100	14	0.53	0.50	91	0.25	1.1				

63	$n_1 = 900$				KC					
	$i_n$	$n_2$ [rpm]	Rd	$P_{t0}$	$T_2$ [Nm]	$P_1$ [kW]	FS'	Input - IEC B5/B14		
	5	180	0.87	—	69	1.5	1.9	90	80	—
7.5	120	0.85	102		1.5	1.4				
10	90	0.83	133		1.5	1.1				
15	60	0.79	139		1.1	1.1				
20	45	0.77	123		0.75	1.4				
25	36	0.74	109		0.55	1.3				
30	30	0.70	122		0.55	1.3				
40	23	0.66	154		0.55	1.1	—	71		
50	18	0.61	120		0.37	1.2				
65	14	0.57	98		0.25	1.4				
80	11	0.54	115		0.25	1.1				
100	9	0.50	95		0.18	1.2				

63	$n_1 = 500$				KC					
	$i_n$	$n_2$ [rpm]	Rd	$P_{t0}$	$T_2$ [Nm]	$P_1$ [kW]	FS'	Input - IEC B5/B14		
	5	100	0.85	—	20	0.25	8.3	90	80	—
7.5	67	0.83	30		0.25	5.9				
10	50	0.81	39		0.25	4.7				
15	33	0.76	55		0.25	3.4				
20	25	0.74	71		0.25	2.8				
25	20	0.71	85		0.25	1.9				
30	17	0.65	94		0.25	2.1				
40	13	0.62	118		0.25	1.7	—	71		
50	10	0.56	135		0.25	1.2				
65	8	0.52	163		0.25	1.0				
80	6	0.50	137		0.18	1.1				
100	5	0.45	77		0.09	1.6				

**\* ATTENZIONE:** la coppia massima utilizzabile [ $T_{2M}$ ] deve essere calcolata utilizzando il fattore di servizio:  
 $T_{2M} = T_2 \times FS'$

**\* WARNING:** Maximum allowable torque [ $T_{2M}$ ] must be calculated using the following service factor:  
 $T_{2M} = T_2 \times FS'$

**\* ACHTUNG:** das max. anwendbare Drehmoment [ $T_{2M}$ ] muss mit folgendem Betriebsfaktor berechnet werden:  
 $T_{2M} = T_2 \times FS'$

**Dati tecnici**
**Technical data**
**Technische Daten**

75	$n_1 = 2800$				KC						
	$i_n$	$n_2$ [rpm]	Rd	$P_{t0}$	$T_2$ [Nm]	$P_1$ [kW]	FS'	Input - IEC B5/B14			
	 8.0	7.5	373	0.89	—	125	<b>5.5</b>	1.0	112 100	90	—
10		280	0.88	120		<b>4</b>	1.2				
15		187	0.85	131		<b>3</b>	1.2				
20		140	0.84	171		<b>3</b>	1.0				
25		112	0.82	154		<b>2.2</b>	1.0				
30		93	0.78	120		<b>1.5</b>	1.4				
40		70	0.75	154		<b>1.5</b>	1.2				
50		56	0.73	136		<b>1.1</b>	1.2				
65		43	0.69	114		<b>0.75</b>	1.4				
80		35	0.66	135		<b>0.75</b>	1.1				
100	28	0.62	159	<b>0.75</b>	0.8						
										80	71

75	$n_1 = 1400$				KC						
	$i_n$	$n_2$ [rpm]	Rd	$P_{t0}$	$T_2$ [Nm]	$P_1$ [kW]	FS'	Input - IEC B5/B14			
	 8.0	7.5	187	0.87	2.5	178	<b>4</b>	1.0	112 100	90	—
10		140	0.86	2.3	176	<b>3</b>	1.1				
15		93	0.83	1.9	187	<b>2.2</b>	1.1				
20		70	0.81	1.7	199	<b>1.8</b>	1.1				
25		56	0.78	1.5	200	<b>1.5</b>	1.0				
30		47	0.74	1.2	167	<b>1.1</b>	1.3				
40		35	0.71	1.1	213	<b>1.1</b>	1.1				
50		28	0.67	1.0	206	<b>0.9</b>	1.0				
65		22	0.63	0.90	154	<b>0.55</b>	1.3				
80		18	0.60	0.80	180	<b>0.55</b>	1.0				
100	14	0.56	0.70	210	<b>0.55</b>	0.8					
										80	71

75	$n_1 = 900$				KC						
	$i_n$	$n_2$ [rpm]	Rd	$P_{t0}$	$T_2$ [Nm]	$P_1$ [kW]	FS'	Input - IEC B5/B14			
	 8.0	7.5	120	0.86	—	205	<b>3</b>	1.0	112 100	90	—
10		90	0.84	197		<b>2.2</b>	1.2				
15		60	0.81	231		<b>1.8</b>	1.0				
20		45	0.78	250		<b>1.5</b>	1.1				
25		36	0.76	221		<b>1.1</b>	1.1				
30		30	0.71	249		<b>1.1</b>	1.0				
40		23	0.67	214		<b>0.75</b>	1.3				
50		18	0.64	186		<b>0.55</b>	1.3				
65		14	0.59	151		<b>0.37</b>	1.5				
80		11	0.56	177		<b>0.37</b>	1.2				
100	9	0.52	203	<b>0.37</b>	0.9						
										80	71

75	$n_1 = 500$				KC						
	$i_n$	$n_2$ [rpm]	Rd	$P_{t0}$	$T_2$ [Nm]	$P_1$ [kW]	FS'	Input - IEC B5/B14			
	 8.0	7.5	67	0.84	—	90	<b>0.75</b>	2.9	112 100	90	—
10		50	0.82	118		<b>0.75</b>	2.4				
15		33	0.78	167		<b>0.75</b>	1.7				
20		25	0.75	216		<b>0.75</b>	1.5				
25		20	0.72	260		<b>0.75</b>	1.1				
30		17	0.67	288		<b>0.75</b>	1.1				
40		13	0.63	265		<b>0.55</b>	1.2				
50		10	0.59	210		<b>0.37</b>	1.3				
65		8	0.55	251		<b>0.37</b>	1.0				
80		6	0.52	197		<b>0.25</b>	1.2				
100	5	0.47	161	<b>0.18</b>	1.3						
										80	71

**\* ATTENZIONE:** la coppia massima utilizzabile  $[T_{2M}]$  deve essere calcolata utilizzando il fattore di servizio:  
 $T_{2M} = T_2 \times FS'$

**\* WARNING:** Maximum allowable torque  $[T_{2M}]$  must be calculated using the following service factor:  
 $T_{2M} = T_2 \times FS'$

**\* ACHTUNG:** das max. anwendbare Drehmoment  $[T_{2M}]$  muss mit folgendem Betriebsfaktor berechnet werden:  
 $T_{2M} = T_2 \times FS'$

**Dati tecnici**
**Technical data**
**Technische Daten**

89	$n_1 = 2800$				KC					
	$i_n$	$n_2$ [rpm]	Rd	$P_{t0}$	$T_2$ [Nm]	$P_1$ [kW]	FS'	Input - IEC B5/B14		
	7.5	373	0.89	—	171	7.5	1.2	112 100	90	—
10	280	0.88	165		5.5	1.3				
15	187	0.86	241		5.5	1.0				
20	140	0.84	230		4	1.2				
25	112	0.83	212		3	1.2				
30	93	0.79	243		3	1.1				
40	70	0.77	230		2.2	1.3				
50	56	0.74	278		2.2	1.0				
65	43	0.71	235		1.5	1.1				
80	35	0.68	205		1.1	1.2				
100	28	0.64	163		0.75	1.3				
	11.5						—		80	

89	$n_1 = 1400$				KC					
	$i_n$	$n_2$ [rpm]	Rd	$P_{t0}$	$T_2$ [Nm]	$P_1$ [kW]	FS'	Input - IEC B5/B14		
	7.5	187	0.88	3.0	247	5.5	1.2	112 100	90	—
10	140	0.86	2.5	236	4	1.3				
15	93	0.84	2.2	256	3	1.2				
20	70	0.82	2.0	334	3	1.1				
25	56	0.80	1.8	299	2.2	1.1				
30	47	0.76	1.5	340	2.2	1.0				
40	35	0.72	1.3	355	1.8	1.1				
50	28	0.69	1.1	353	1.5	1.0				
65	22	0.65	1.0	317	1.1	1.0				
80	18	0.63	1.0	309	0.9	1.0				
100	14	0.58	0.80	217	0.55	1.2				
	11.5						—		80	

89	$n_1 = 900$				KC					
	$i_n$	$n_2$ [rpm]	Rd	$P_{t0}$	$T_2$ [Nm]	$P_1$ [kW]	FS'	Input - IEC B5/B14		
	7.5	120	0.86	—	206	3	1.7	112 100	90	—
10	90	0.85	270		3	1.3				
15	60	0.82	286		2.2	1.3				
20	45	0.79	371		2.2	1.1				
25	36	0.77	369		1.8	1.0				
30	30	0.73	416		1.8	1.0				
40	23	0.69	440		1.5	1.0				
50	18	0.66	384		1.1	1.0				
65	14	0.62	319		0.75	1.1				
80	11	0.59	274		0.55	1.2				
100	9	0.54	313		0.55	1.0				
	11.5						—		80	

89	$n_1 = 500$				KC					
	$i_n$	$n_2$ [rpm]	Rd	$P_{t0}$	$T_2$ [Nm]	$P_1$ [kW]	FS'	Input - IEC B5/B14		
	7.5	67	0.84	—	91	0.75	4.7	112 100	90	—
10	50	0.83	118		0.75	3.7				
15	33	0.79	169		0.75	2.7				
20	25	0.76	219		0.75	2.3				
25	20	0.74	265		0.75	1.7				
30	17	0.68	294		0.75	1.6				
40	13	0.65	371		0.75	1.4				
50	10	0.61	439		0.75	1.1				
65	8	0.57	388		0.55	1.1				
80	6	0.54	305		0.37	1.3				
100	5	0.49	344		0.37	1.0				
	11.5						—		80	

**\* ATTENZIONE:** la coppia massima utilizzabile  $[T_{2M}]$  deve essere calcolata utilizzando il fattore di servizio:  
 $T_{2M} = T_2 \times FS'$

**\* WARNING:** Maximum allowable torque  $[T_{2M}]$  must be calculated using the following service factor:  
 $T_{2M} = T_2 \times FS'$

**\* ACHTUNG:** das max. anwendbare Drehmoment  $[T_{2M}]$  muss mit folgendem Betriebsfaktor berechnet werden:  
 $T_{2M} = T_2 \times FS'$

**Dati tecnici**
**Technical data**
**Technische Daten**

90	$n_1 = 2800$				KC					
	$i_n$	$n_2$ [rpm]	Rd	$P_{t0}$	$T_2$ [Nm]	$P_1$ [kW]	FS'	Input - IEC B5/B14		
	 16.4	7.5	373	0.89	—	171	7.5	1.2	112 100	90
10		280	0.88	165		5.5	1.3			
15		187	0.86	241		5.5	1.0			
20		140	0.84	230		4	1.2			
25		112	0.83	212		3	1.2			
30		93	0.79	243		3	1.1			
40		70	0.77	230		2.2	1.3			
50		56	0.74	278		2.2	1.0			
65		43	0.71	235		1.5	1.1			
80		35	0.68	205		1.1	1.2			
100	28	0.64	163	0.75	1.3					

90	$n_1 = 1400$				KC					
	$i_n$	$n_2$ [rpm]	Rd	$P_{t0}$	$T_2$ [Nm]	$P_1$ [kW]	FS'	Input - IEC B5/B14		
	 16.4	7.5	187	0.88	3.0	247	5.5	1.2	112 100	90
10		140	0.86	2.5	236	4	1.3			
15		93	0.84	2.2	256	3	1.2			
20		70	0.82	2.0	334	3	1.1			
25		56	0.80	1.8	299	2.2	1.1			
30		47	0.76	1.5	340	2.2	1.0			
40		35	0.72	1.3	355	1.8	1.1			
50		28	0.69	1.1	353	1.5	1.0			
65		22	0.65	1.0	317	1.1	1.0			
80		18	0.63	1.0	309	0.9	1.0			
100	14	0.58	0.80	217	0.55	1.2				

90	$n_1 = 900$				KC					
	$i_n$	$n_2$ [rpm]	Rd	$P_{t0}$	$T_2$ [Nm]	$P_1$ [kW]	FS'	Input - IEC B5/B14		
	 16.4	7.5	120	0.86	—	206	3	1.7	112 100	90
10		90	0.85	270		3	1.3			
15		60	0.82	286		2.2	1.3			
20		45	0.79	371		2.2	1.1			
25		36	0.77	369		1.8	1.0			
30		30	0.73	416		1.8	1.0			
40		23	0.69	440		1.5	1.0			
50		18	0.66	384		1.1	1.0			
65		14	0.62	319		0.75	1.1			
80		11	0.59	274		0.55	1.2			
100	9	0.54	313	0.55	1.0					

90	$n_1 = 500$				KC					
	$i_n$	$n_2$ [rpm]	Rd	$P_{t0}$	$T_2$ [Nm]	$P_1$ [kW]	FS'	Input - IEC B5/B14		
	 16.4	7.5	67	0.84	—	91	0.75	4.7	112 100	90
10		50	0.83	118		0.75	3.7			
15		33	0.79	169		0.75	2.7			
20		25	0.76	219		0.75	2.3			
25		20	0.74	265		0.75	1.7			
30		17	0.68	294		0.75	1.6			
40		13	0.65	371		0.75	1.4			
50		10	0.61	439		0.75	1.1			
65		8	0.57	388		0.55	1.1			
80		6	0.54	305		0.37	1.3			
100	5	0.49	344	0.37	1.0					

**\* ATTENZIONE:** la coppia massima utilizzabile  $[T_{2M}]$  deve essere calcolata utilizzando il fattore di servizio:  
 $T_{2M} = T_2 \times FS'$

**\* WARNING:** Maximum allowable torque  $[T_{2M}]$  must be calculated using the following service factor:  
 $T_{2M} = T_2 \times FS'$

**\* ACHTUNG:** das max. anwendbare Drehmoment  $[T_{2M}]$  muss mit folgendem Betriebsfaktor berechnet werden:  
 $T_{2M} = T_2 \times FS'$

**Dati tecnici**
**Technical data**
**Technische Daten**

110	$n_1 = 2800$				KC					
	$i_n$	$n_2$ [rpm]	Rd	$P_{t0}$	$T_2$ [Nm]	$P_1$ [kW]	FS'	Input - IEC B5/B14		
	7.5	373	0.89	—	343	15	1.0	132	112 100	—
10	280	0.88	332		11	1.1				
15	187	0.86	331		7.5	1.2				
20	140	0.85	435		7.5	1.1				
25	112	0.84	393		5.5	1.1				
30	93	0.80	450		5.5	1.0				
40	70	0.78	424		4	1.2	—	90		
50	56	0.76	388		3	1.2		—		
65	43	0.73	354		2.2	1.2		—		
80	35	0.70	287		1.5	1.4		—		
100	28	0.66	339		1.5	1.1		—		90

110	$n_1 = 1400$				KC					
	$i_n$	$n_2$ [rpm]	Rd	$P_{t0}$	$T_2$ [Nm]	$P_1$ [kW]	FS'	Input - IEC B5/B14		
	7.5	187	0.88	4.3	415	9.2	1.2	132	112 100	—
10	140	0.87	4.0	446	7.5	1.1				
15	93	0.84	3.2	475	5.5	1.1				
20	70	0.83	3.0	623	5.5	1.0				
25	56	0.81	2.7	554	4	1.0				
30	47	0.77	2.2	472	3	1.3	—	90		
40	35	0.74	2.0	606	3	1.1		—		
50	28	0.72	1.8	538	2.2	1.1		—		
65	22	0.68	1.6	451	1.5	1.2		—		
80	18	0.65	1.5	390	1.1	1.3		—		90
100	14	0.61	1.3	458	1.1	1.0	—	90		

110	$n_1 = 900$				KC					
	$i_n$	$n_2$ [rpm]	Rd	$P_{t0}$	$T_2$ [Nm]	$P_1$ [kW]	FS'	Input - IEC B5/B14		
	7.5	120	0.87	—	381	5.5	1.5	132	112 100	—
10	90	0.86	500		5.5	1.2				
15	60	0.83	526		4	1.2				
20	45	0.81	685		4	1.1				
25	36	0.79	628		3	1.1				
30	30	0.74	520		2.2	1.3	—	90		
40	23	0.71	664		2.2	1.1		—		
50	18	0.68	653		1.8	1.1		—		
65	14	0.64	487		1.1	1.2		—		
80	11	0.61	570		1.1	1.0		—		90
100	9	0.57	450		0.75	1.1	—	90		

110	$n_1 = 500$				KC					
	$i_n$	$n_2$ [rpm]	Rd	$P_{t0}$	$T_2$ [Nm]	$P_1$ [kW]	FS'	Input - IEC B5/B14		
	7.5	67	0.85	—	183	1.5	3.9	132	112 100	—
10	50	0.84	240		1.5	3.1				
15	33	0.80	344		1.5	2.3				
20	25	0.78	446		1.5	1.9				
25	20	0.76	542		1.5	1.5				
30	17	0.70	603		1.5	1.4	—	90		
40	13	0.67	765		1.5	1.2		—		
50	10	0.64	671		1.1	1.2		—		
65	8	0.59	553		0.75	1.3		—		
80	6	0.56	643		0.75	1.0		—		90
100	5	0.52	542		0.55	1.1	—	90		

**\* ATTENZIONE:** la coppia massima utilizzabile  $[T_{2M}]$  deve essere calcolata utilizzando il fattore di servizio:  
 $T_{2M} = T_2 \times FS'$

**\* WARNING:** Maximum allowable torque  $[T_{2M}]$  must be calculated using the following service factor:  
 $T_{2M} = T_2 \times FS'$

**\* ACHTUNG:** das max. anwendbare Drehmoment  $[T_{2M}]$  muss mit folgendem Betriebsfaktor berechnet werden:  
 $T_{2M} = T_2 \times FS'$

**Dati tecnici**
**Technical data**
**Technische Daten**

130	$n_1 = 2800$				KC					
	$i_n$	$n_2$ [rpm]	Rd	$P_{t0}$	$T_2$ [Nm]	$P_1$ [kW]	FS'	Input - IEC B5/B14		
	45	7.5	373	0.90	—	345	15	1.5	132	112 100
	10	280	0.89	455		15	1.2			
	15	187	0.87	490		11	1.3			
	20	140	0.86	645		11	1.1			
	25	112	0.85	667		9.2	1.1			
	30	93	0.81	622		7.5	1.2			
	40	70	0.80	819		7.5	1.0	—	90	
	50	56	0.78	732		5.5	1.0			
	65	43	0.75	499		3	1.3			
	80	35	0.73	598		3	1.1			
	100	28	0.70	525		2.2	1.1			

130	$n_1 = 1400$				KC					
	$i_n$	$n_2$ [rpm]	Rd	$P_{t0}$	$T_2$ [Nm]	$P_1$ [kW]	FS'	Input - IEC B5/B14		
	45	7.5	187	0.89	6.0	418	9.2	1.8	132	112 100
	10	140	0.88	5.5	552	9.2	1.4			
	15	93	0.85	4.4	803	9.2	1.1			
	20	70	0.84	4.1	860	7.5	1.1			
	25	56	0.83	3.9	778	5.5	1.2			
	30	47	0.79	3.2	883	5.5	1.1			
	40	35	0.76	2.8	829	4	1.3	—	90	
	50	28	0.74	2.6	757	3	1.3			
	65	22	0.71	2.3	678	2.2	1.2			
	80	18	0.68	2.1	649	1.8	1.2			
	100	14	0.64	1.8	655	1.5	1.1			

130	$n_1 = 900$				KC					
	$i_n$	$n_2$ [rpm]	Rd	$P_{t0}$	$T_2$ [Nm]	$P_1$ [kW]	FS'	Input - IEC B5/B14		
	45	7.5	120	0.88	—	385	5.5	2.3	132	112 100
	10	90	0.87	508		5.5	1.8			
	15	60	0.84	735		5.5	1.4			
	20	45	0.82	957		5.5	1.2			
	25	36	0.81	860		4	1.3			
	30	30	0.76	968		4	1.2			
	40	23	0.73	930		3	1.3	—	90	
	50	18	0.70	817		2.2	1.3			
	65	14	0.67	832		1.8	1.1			
	80	11	0.64	815		1.5	1.1			
	100	9	0.60	700		1.10	1.2			

130	$n_1 = 500$				KC					
	$i_n$	$n_2$ [rpm]	Rd	$P_{t0}$	$T_2$ [Nm]	$P_1$ [kW]	FS'	Input - IEC B5/B14		
	45	7.5	67	0.86	—	228	1.85	4.9	132	112 100
	10	50	0.84	297		1.85	3.7			
	15	33	0.81	429		1.85	2.9			
	20	25	0.79	558		1.85	2.5			
	25	20	0.78	689		1.85	1.8			
	30	17	0.72	763		1.85	1.7			
	40	13	0.69	975		1.85	1.5	—	90	
	50	10	0.66	1166		1.85	1.1			
	65	8	0.63	860		1.10	1.3			
	80	6	0.59	992		1.10	1.1			
	100	5	0.55	788		0.75	1.2			

**\* ATTENZIONE:** la coppia massima utilizzabile  $[T_{2M}]$  deve essere calcolata utilizzando il fattore di servizio:  
 $T_{2M} = T_2 \times FS'$

**\* WARNING:** Maximum allowable torque  $[T_{2M}]$  must be calculated using the following service factor:  
 $T_{2M} = T_2 \times FS'$

**\* ACHTUNG:** das max. anwendbare Drehmoment  $[T_{2M}]$  muss mit folgendem Betriebsfaktor berechnet werden:  
 $T_{2M} = T_2 \times FS'$

**Momenti d'inerzia**
**Moments of inertia**
**Trägheitsmoment**

	$i_n$	KC 	
		B5 - B14	
		IEC 56	IEC 63
<b>K30</b>	5	0.130	0.127
	7.5	0.112	0.109
	10	0.103	0.100
	15	0.097	0.094
	20	0.095	0.092
	25	0.094	0.091
	30	0.093	0.090
	40	0.093	0.090
	50	0.092	0.089
	65	0.079	-
	80	0.079	-
	100	0.078	-

	$i_n$	KC 		
		B5 - B14		
		IEC 56	IEC 63	IEC 71
<b>K40</b>	5	-	0.391	0.463
	7.5	-	0.321	0.356
	10	-	0.272	0.347
	15	-	0.266	0.340
	20	-	0.263	0.338
	25	-	0.262	0.337
	30	-	0.262	0.337
	40	-	0.261	0.336
	50	0.182	0.261	-
	65	0.182	0.261	-
	80	0.182	0.261	-
	100	0.182	0.261	-

	$i_n$	KC 		
		B5 - B14		
		IEC 63	IEC 71	IEC 80
<b>K50</b>	5	-	0.922	1.046
	7.5	-	0.684	0.935
	10	-	0.602	0.853
	15	-	0.543	0.794
	20	-	0.523	0.774
	25	-	0.513	0.764
	30	-	0.508	0.759
	40	0.315	0.503	-
	50	0.313	0.501	-
	65	0.311	0.499	-
	80	0.310	0.498	-
	100	0.309	0.498	-

	$i_n$	KC 		
		B5 - B14		
		IEC 71	IEC 80	IEC 63
<b>K63</b>	5	-	2.431	2.671
	7.5	-	1.949	2.269
	10	-	1.744	2.063
	15	-	1.597	1.916
	20	-	1.545	1.864
	25	-	1.514	1.833
	30	-	1.508	1.828
	40	0.966	1.495	-
	50	0.959	1.488	-
	65	0.955	1.484	-
	80	0.953	1.482	-
	100	0.952	1.481	-

 Momenti d'inerzia [kg·cm<sup>2</sup>]  
 riferiti all'albero veloce in entrata

 Moments of inertia [kg·cm<sup>2</sup>]  
 referred to input shaft

 Trägheitsmoment [kg·cm<sup>2</sup>]  
 bez. Antriebswelle

**Momenti d'inerzia**
**Moments of inertia**
**Trägheitsmoment**

	$i_n$	KC 			
		B5 - B14			
		IEC 71	IEC 80	IEC 90	IEC 100-112
<b>K75</b>	7.5	-	-	3.712	4.462
	10	-	-	3.234	3.984
	15	-	-	2.893	3.643
	20	-	-	2.774	3.523
	25	-	-	2.709	3.458
	30	1.615	1.575	2.689	3.438
	40	-	1.573	2.659	-
	50	-	1.570	2.642	-
	65	1.609	1.569	2.633	-
	80	1.605	1.565	2.629	-
	100	1.602	1.562	2.626	-

	$i_n$	KC 		
		B5 - B14		
		IEC 80	IEC 90	IEC 100-112
<b>K89</b>	7.5	-	6.898	7.671
	10	-	5.875	6.648
	15	-	5.144	5.917
	20	-	3.398	5.661
	25	-	3.256	5.520
	30	-	3.215	5.479
	40	-	3.151	5.411
	50	-	3.115	-
	65	2.024	3.096	-
	80	2.014	3.087	-
	100	2.008	3.080	-

	$i_n$	KC 		
		B5 - B14		
		IEC 80	IEC 90	IEC 100-112
<b>K90</b>	7.5	-	6.898	7.671
	10	-	5.875	6.648
	15	-	5.144	5.917
	20	-	3.398	5.661
	25	-	3.256	5.520
	30	-	3.215	5.479
	40	-	3.151	5.411
	50	-	3.115	-
	65	2.024	3.096	-
	80	2.014	3.087	-
	100	2.008	3.080	-

	$i_n$	KC 		
		B5 - B14		
		IEC 90	IEC 100-112	IEC 132
<b>K110</b>	7.5	-	17.980	20.038
	10	-	15.119	17.177
	15	-	13.076	15.134
	20	-	8.367	14.418
	25	-	7.969	14.020
	30	-	11.850	13.908
	40	-	7.677	-
	50	-	7.578	-
	65	5.592	7.510	-
	80	5.570	7.489	-
	100	5.555	7.474	-

	$i_n$	KC 		
		B5 - B14		
		IEC 90	IEC 100-112	IEC 132
<b>K130</b>	7.5	-	40.70	42.78
	10	-	32.96	35.04
	15	-	27.43	29.51
	20	-	16.68	27.58
	25	-	15.52	26.42
	30	-	24.12	26.20
	40	-	14.81	25.71
	50	-	12.57	-
	65	10.46	14.35	-
	80	10.41	14.30	-
	100	10.37	14.26	-

Momenti d'inerzia [kg·cm<sup>2</sup>]  
 riferiti all'albero veloce in entrata

Moments of inertia [kg·cm<sup>2</sup>]  
 referred to input shaft

Trägheitsmoment [kg·cm<sup>2</sup>]  
 bez. Antriebswelle

**Dimensioni**

**Dimensions**

**Abmessungen**

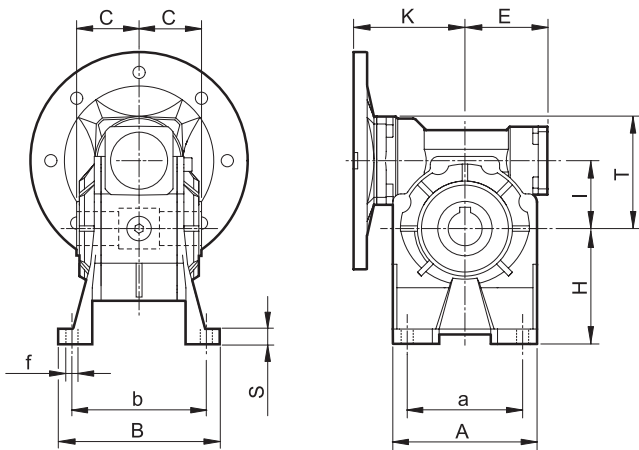

**KC..A**

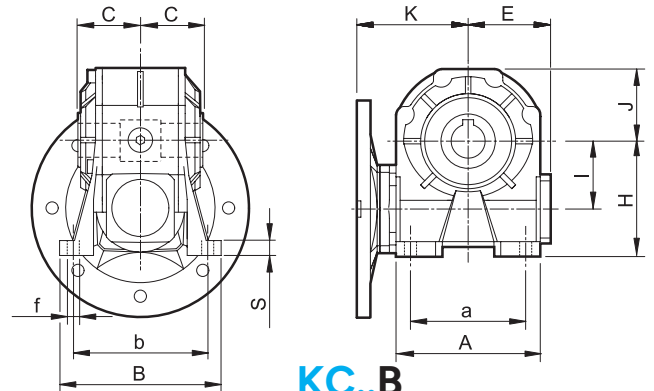

**KC..B**

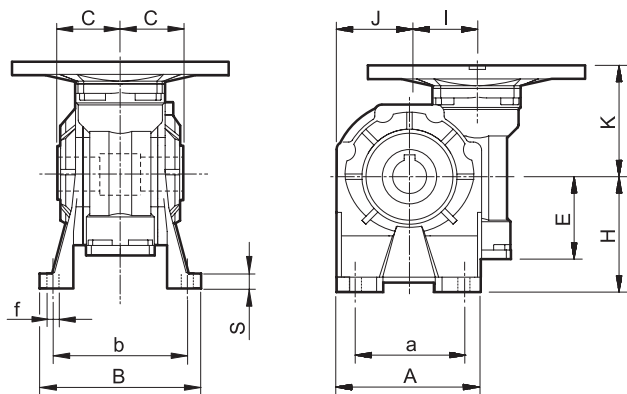

**KC..V**

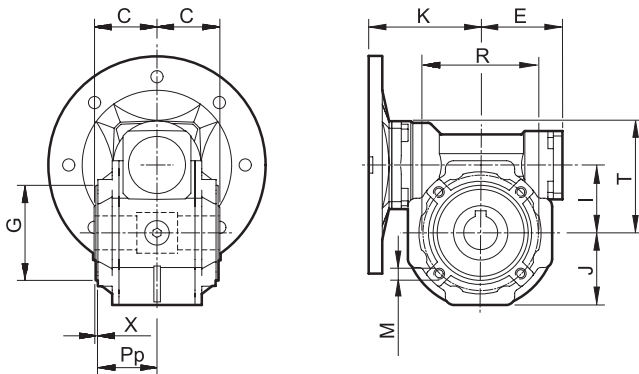

Flangia pendolare / Side cover for shaft mounting / Aufsteckflansch

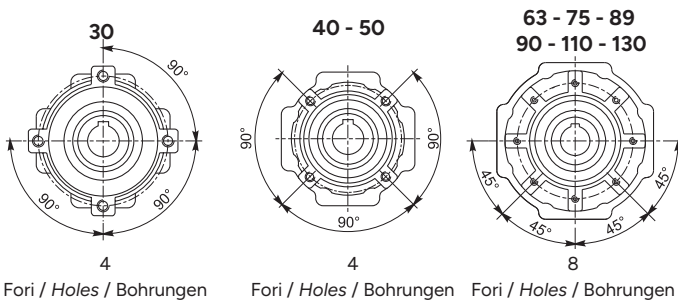

Fori / Holes / Bohrungen

Fori / Holes / Bohrungen

Fori / Holes / Bohrungen

**KC..P**

	30	40	50	63	75	89 - 90	110	130
<b>b2</b>	5	6 (6)	8 (8)	8	8 (8)	10 (10)	12	14
<b>C</b>	31.5	39	46	56	60	70	77.5	85
<b>D2 H8</b>	14	18 (19)	25 (24)	25	28 (30)	35 (32)	42	45 (48)
<b>E</b>	41	51	60	71	85	103	127.5	147.5
<b>G h8</b>	55	60	70	80	95	110	130	180
<b>I</b>	31.5	40	50	63	75	90	110	130
<b>J</b>	37.5	43.5	53.5	64	78	100	122	131
<b>K</b>	57	75	82	97	114 112 <sup>(1)</sup>	122	153	173
<b>M</b>	M6x8	M6x10	M8x10	M8x14	M8x14	M10x18	M10x18	M12x20
<b>Pp</b>	29	36.5	43.5	53	57	67	74	81
<b>R</b>	65	75	85	95	115	130	165	215
<b>T</b>	52.5	68.5	82.5	100.5	116.5	131.5	161.5	181
<b>t2</b>	16.3	20.8 (21.8)	28.3 (27.3)	28.3	31.3 (33.3)	38.3 (35.3)	45.3	48.8 (51.8)
<b>X</b>	1.5	1.5	1.5	2	2	2	2.5	3

(1): Solo per PAM 71B14 / Only for PAM 71B14 / Nur PAM 71B14

	Piedi Feet Füß	30	40	50	63	75	89 - 90	110	130
<b>A</b>	1	67	86.5	106	127.5	155.5	190	250	295
	2	67	86.5	106			190	250	
<b>a</b>	1	40-52	70	63-85	95	120	140	200	235
	2	40-52	52	63-85			140	200	220
<b>B</b>	1	78	98	119	136	140	168	210	229
	2	78	98	119			168	210	
<b>b</b>	1	66	84	99	111	115	140	162	190
	2	66	81	99			146	181	191
<b>f</b>	1	6.5	7	9	11	11	13	13	15
	2	6.5	8.5	9			11	13	
<b>H</b>	1	52	71	85	100	115	135	172	200
	2	55	72	82			142	170	195
<b>S</b>	1	5	9	11	12	12	14	17	20
	2	8	10	8			14	15	15

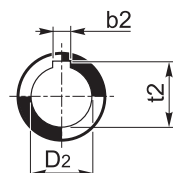

Albero uscita cavo  
Hollow output shaft  
Abtriebshohlwelle

**Dimensioni**

**Dimensions**

**Abmessungen**

Flangia uscita / Output flange / Abtriebsflansch

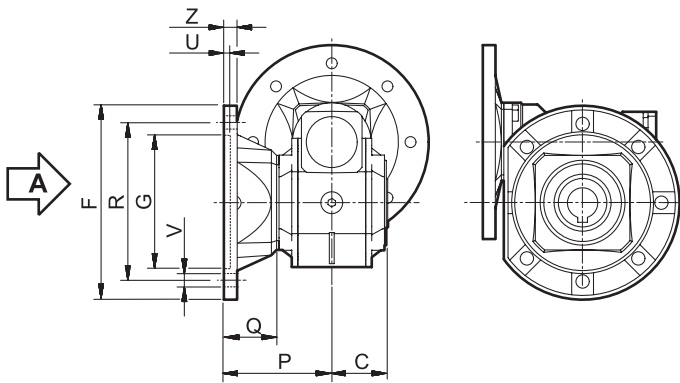

**KC..F**

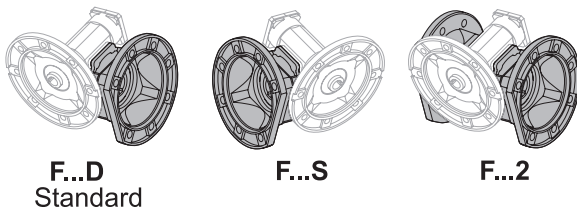

Vista da A / View from A / Ansicht von A

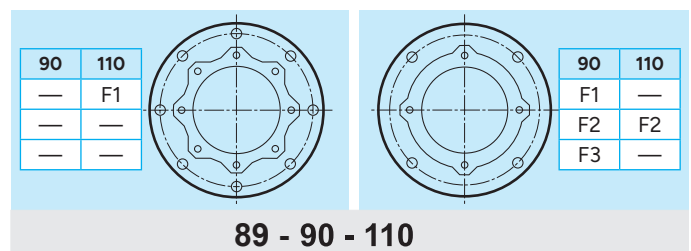
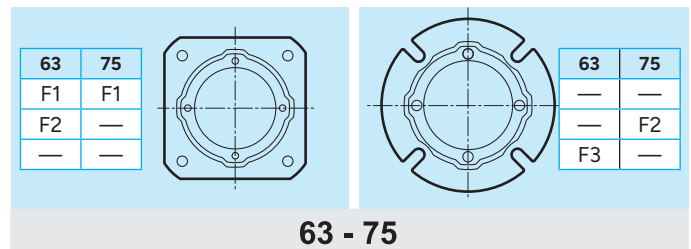
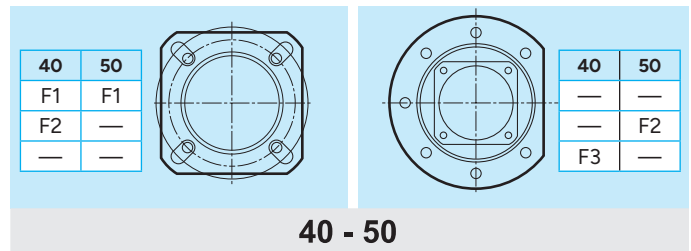
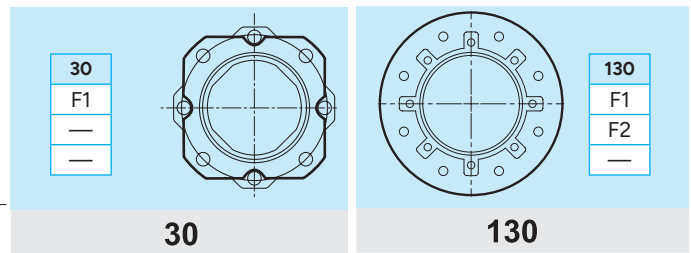

KC		C	F		G H8	P	Q	R	U	V		Z	
30	F1	31.5		66	50	54.5	23	68	4	n° 4	6.5	6	
	F2												
	F3												
40	F1	39		85	60	67	28	75-90	4	n° 4	9	8	
	F2			85	60	97	58	75-90	4	n° 4	9	8	
	F3		140		95	80	41	115	5		n° 7	9	10
50	F1	46		94	70	90	44	85-100	5	n° 4	11	10	
	F2			160	110	89	43	130	5		n° 7	11	11
	F3												
63	F1	56		142	115	82	26	150	5	n° 4	11	11	
	F2			142	115	112	56	150	5	n° 4	11	11	
	F3		160		110	80.5	24.5	130	5	n° 4	11	12	
75	F1	60		160	130	111	51	165	5	n° 4	13	12	
	F2			160	110	90	30	130	6	n° 4	11	13	
	F3												
89 90	F1	70	200		152	111	41	175	5	n° 4	13	12	
	F2		200		152	151	81	175	5	n° 4	13	13	
	F3		200		130	110	40	165	6	n° 4	11	11	
110	F1	77.5	260		170	131	53.5	230	6		n° 8	13	15
	F2		250		180	150	72.5	215	5	n° 4	15	16	
	F3												
130	F1	85	320		180			255	7		n° 8 *	16	16
	F2		300		230	140	55	265					
	F3												

\* Foratura ruotata di 22.5°

\* Drilling turned of 22.5°

\* Durchbohrung 22.5° versetzt



## Entrata supplementare (Vite bisporgente)

## Additional input (double extended shaft)

## Zusatzantrieb (beidseitige Welle)

S.e.A.

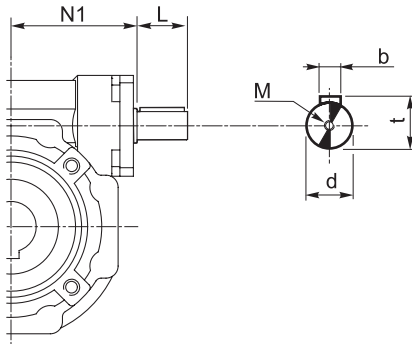

KC	d j6	L	M	N1	b	t
30	9	15	M4x10	42.5	3	10.2
40	11	20	M4x12	52.5	4	12.5
50	14	25	M5x13	62.5	5	16
63	19	30	M8x20	72.5	6	21.5
75	24	40	M8x20	89	8	27
89 - 90	24	40	M8x20	108	8	27
110	28	50	M8x20	132.5	8	31
130	38	70	M10x25	152	10	41

## Limitatore di coppia cavo passante

## Torque limiter with through hollow shaft

## Drehmomentbegrenzer mit durchgehender Hohlwelle

Il limitatore di coppia viene consigliato in tutte quelle applicazioni che richiedono una limitazione sulla coppia trasmissibile per proteggere l'impianto e/o preservare il riduttore evitando sovraccarichi o urti indesiderati quanto inaspettati.

È un dispositivo con albero dotato di cavo passante, con funzionamento a frizione, ed è integrato al riduttore, presentando un ingombro limitato. Concepito per lavorare a bagno d'olio, il dispositivo risulta affidabile nel tempo ed è esente da usura se non viene mantenuto in condizioni prolungate di slittamento (condizione che si verifica quando la coppia presenta valori superiori a quelli di taratura). La taratura è facilmente regolabile dall'esterno attraverso il serraggio di una ghiera autobloccante che porta a compressione le 4 molle a tazza disposte tra loro in serie.

Il dispositivo non consente:

- l'impiego di cuscinetti a rulli conici in uscita
- funzionamento prolungato in condizioni di slittamento.

Nella tabella seguente vengono riportati i valori delle coppie di slittamento  $M_{2S}$  in funzione del n° di giri della ghiera. I valori di taratura presentano una tolleranza del  $\pm 10\%$  e si riferiscono ad una condizione statica.

In condizioni dinamiche è da notare che la coppia di slittamento assume valori diversi a seconda del tipo e/o modalità in cui si verifica il sovraccarico: con valori maggiori in caso di carico uniformemente crescente rispetto a valori più contenuti in seguito al verificarsi di picchi improvvisi di carico.

**NOTA:** quando si supera il valore di taratura si ha slittamento. Il coefficiente di attrito tra le superfici di contatto da statico diventa dinamico e la coppia trasmessa cala del 30% circa. E' quindi opportuno prevedere uno stop per poter ripartire al valore di taratura iniziale.

*The use of a torque limiter is advisable when the application requires the limitation of the transmissible torque to safeguard the plant and/or the gearbox from unexpected or undesired overloads.*

*The torque limiter is equipped with a through hollow shaft and a friction clutch. It is integrated in the gearbox, therefore space requirement is limited. Designed to be working in oil bath, the device is reliable over time and is not subject to wear unless in case of operation with prolonged slipping (it occurs when the torque values are higher than the calibration values). Calibration can be easily adjusted from outside by tightening the self-locking ring nut, which causes the compression of the 4 Belleville washers arranged in series.*

*The device does not go together with:*

- the use of tapered roller bearings at output
- prolonged operation under slipping conditions

*The following table shows the values of  $M_{2S}$  slipping torques depending on the number of revolutions of the ring nut. Calibration values feature a  $\pm 10\%$  tolerance and refer to static conditions. Under dynamic conditions the values of the slipping torque will change according to the type of overload: the values are higher if the load increase is uniform; the values are lower if sudden load peaks occur.*

**NOTE:** Slipping occurs when the setting values are exceeded.

*The friction coefficient between the contact surfaces from static becomes dynamic and the transmitted torque is approx. 30% lower.*

*It is advisable to have a stop first in order to have a restart based on the initial setting value.*

Die Anwendung eines Drehmomentbegrenzers wird empfohlen, um die Anlage und/oder das Getriebe gegen ungewünschte und unerwartete Überbelastungen zu schützen.

Es handelt sich um eine Vorrichtung mit einer durchgehender Hohlwelle. Er ist in dem Getriebe integriert, d.h. der Raumbedarf ist klein. Der Begrenzer wurde für Betrieb in einem Ölbad entworfen.

Er ist zuverlässig über Zeit und verschleißfest (ausser wenn Rutschen für lange Zeit besteht: das passiert, wenn das Drehmoment höher als der Eichwert ist).

Die Einstellung darf mühelos von aussen durch das Anziehen einer selbstsperrenden Mutter ausgeführt werden. Das Anziehen verursacht die Zusammendrückung der 4 wechselsinniggeschichteten Tellerfeder.

Die Vorrichtung sieht das folgende nicht vor:

- die Verwendung von Kegelrollenlager am Abtrieb
- Längerer Rutschbetrieb

Die nachstehende Tabelle zeigt die Werte der Rutschmomente  $M_{2S}$  abhängig von der Zahl der Umdrehungen der Mutter.

Die Eichwerte weisen  $\pm 10\%$  Toleranz auf und beziehen sich auf statische Bedingungen.

Unter dynamischen Bedingungen hat das Rutschmoment verschiedene Werte je nach Art der Überbelastung. Die Werte sind höher, wenn die Belastung gleichmäßig zunimmt; sie sind niedriger im Falle von plötzlichen Belastungsspitzen.

**BEMERKUNG:** Rutschen tritt auf, wenn die eingestellten Werte überschritten werden. Der Reibungskoeffizient zwischen den Berührungsflächen wird dynamisch anstatt statisch und das übertragene Drehmoment sinkt um ca. 30%.

Es ist daher ratsam, vor dem erneuten Anfahren anzuhalten, um die ursprünglichen Drehmomentwerte zu erreichen.

## Limitatore di coppia cavo passante

È importante notare che la coppia di slittamento non resta sempre la medesima durante tutta la vita del limitatore.

Tende infatti a diminuire in rapporto al numero e alla durata degli slittamenti che, rodando le superfici di contatto, ne aumentano il rendimento.

È quindi opportuno verificare periodicamente, soprattutto durante la fase di rodaggio, la taratura del dispositivo.

Là dove sia richiesto un errore più contenuto nella taratura, è necessario testare la coppia trasmissibile sull'impianto.

Il dispositivo viene consegnato tarato alla coppia riportata a catalogo  $T_{2M}$  salvo diversa indicazione espressa in fase di ordinazione.

## Torque limiter with through hollow shaft

*It is important to note that the slipping torque is not the same for the entire life of the torque limiter.*

*It usually decreases in connection with the number and the duration of slippings, this is due to the surfaces of the torque limiter becoming more engaged, therefore increasing the efficiency.*

*For this reason it is advisable to check the calibration of the device at regular intervals, specially during the running-in period.*

*Should a smaller calibration error be required, it is necessary to test the transmissible torque on the plant.*

*The torque limiter is supplied already calibrated at the torque value reported in the catalogue  $T_{2M}$ , unless otherwise specified in the order.*

## Drehmomentbegrenzer mit durchgehender Hohlwelle

Es ist wichtig zu beachten, dass das Rutschmoment der Rutschkupplung über die gesamte Lebensdauer nicht konstant bleibt, sondern üblicherweise in Verbindung mit längeren Rutschzyklen aufgrund der eingelaufenen Berührungsflächen abnimmt.

Deswegen ist es ratsam, die Einstellung der Vorrichtung besonders während der Einlaufzeit in regelmäßigen Zeitabständen zu prüfen.

Falls ein niedriger Eichfehler verlangt wird, ist das übersetzbare Drehmoment auf der Anlage zu testen.

Wenn die Vorrichtung geliefert wird, ist sie schon auf dem im Katalog  $T_{2M}$  angegebenen Drehmoment geeicht, ausser wenn es in der Bestellung anders angegeben wird.

K	N°. giri della ghiera di regolazione / N°. revolutions of ring nut / Nr. Umdrehungen der Mutter															
	3/4	1	1 1/4	1 1/2	1 3/4	2	2 1/4	2 1/2	2 3/4	3	3 1/4	3 1/2	3 3/4	4	4 1/4	4 1/2
	$M_{2S}$ [Nm]															
30		15	18	22	27	32										
40	23	30	35	40	45	50	60									
50		45	60	70	80	90	100	110								
63			80	90	100	110	120	130	140	150	160	170	180	190	200	
75		140	160	180	200	220	240	260	280	300						
89 - 90						230	280	310	330	350	380	410	435	460	490	510
110		420	500	560	670	730	810	910								
130																

Disposizione delle molle  
 Washers' arrangement  
 Lage der Feder

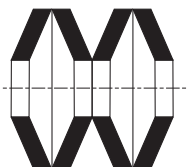

**IN SERIE** (min. coppia, max. sensibilità)  
**SERIES** (min. torque, max. sensitivity)  
**SERIE** (min. Moment, max. Empfindlichkeit)

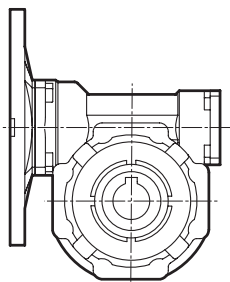
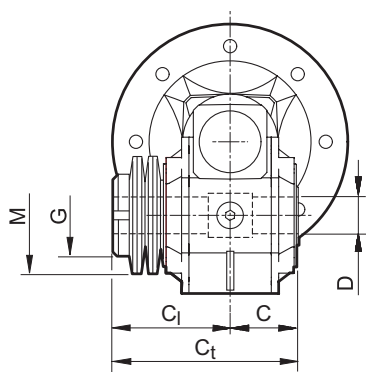

KC	C	C <sub>1</sub>	C <sub>t</sub>	D <sub>H8</sub>	M	G
30	31.5	55.5	87	14	50x25.4x1.25	M25x1.5
40	39	65	104	18 (19)	56x30.5x1.5	M30x1.5
50	46	76	122	25 (24)	63x40.5x1.8	M40x1.5
63	56	91	147	25	71x40.5x2	M40x1.5
75	60	100	160	28 (30)	90x50.5x2.5	M50x1.5
89 - 90	70	109	179	35 (32)	100x51x2.7	M50x1.5
110	77.5	127.5	205	42	125x61x4	M60x2.0
130						

( ) A richiesta / On request / Auf Anfrage

Nella versione con limitatore non è prevista la fornitura degli alberi lenti.

*The version with torque limiter is supplied without output shafts.*

Die Version mit Drehmomentbegrenzer wird ohne Abtriebswellen geliefert.

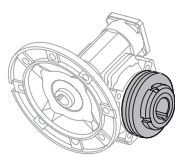

LD

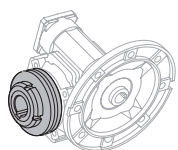

LS

### Accessori

### Accessories

### Zubehör

#### Albero lento

Albero lento semplice  
Single output shaft  
Standard Abtriebswelle

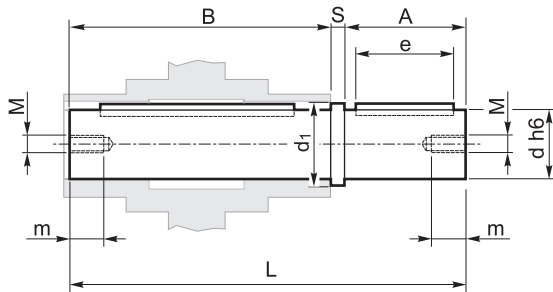

KC	A	B	d <sub>h6</sub>	d <sub>1</sub>	e	L	M	m	S
30	30	62	14	18.5	20	94.5	M6	16	2.5
40	40	77	18	19	23.5	120	M6	16	3
50	50	90	25	24	31.5	143.5	M8	22	3.5
63	50	111	25	31.5	40	165	M8	22	4
75	60	119	28	30	34.5	183	M8	22	4
89 - 90	80	139	35	41.5	60	224	M10	28	5
110	80	154.5	42	49.5	60	242.5	M10	28	8
130	80	168	45	54.5	70	253	M16	36	5

#### Output shaft

#### Abtriebswelle

Albero lento doppio  
Double output shaft  
Doppelte Abtriebswelle

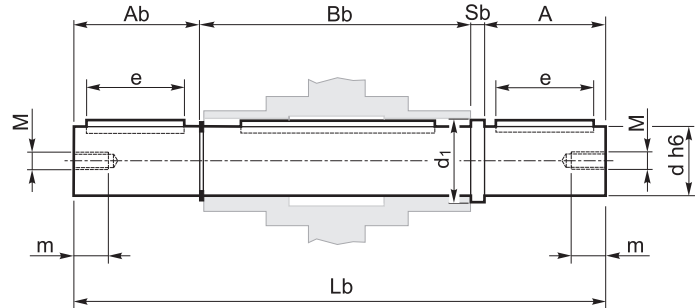

A	A <sub>b</sub>	B <sub>b</sub>	d <sub>h6</sub>	d <sub>1</sub>	e	L <sub>b</sub>	S <sub>b</sub>
30	29	64	14	18.5	20	126	2.5
40	39	79	18	23.5	30	161	3
50	49	93	25	31.5	40	195.5	3.5
50	49	113	25	31.5	40	216	4
60	59	121	28	34.5	50	244	4
80	78.5	141.5	35	41.5	60	305	5
80	77.5	157	42	49.5	60	322.5	8
80	78	172	45	54.5	70	335	5

#### Braccio di reazione

#### Torque arm

#### Drehmomentstütze

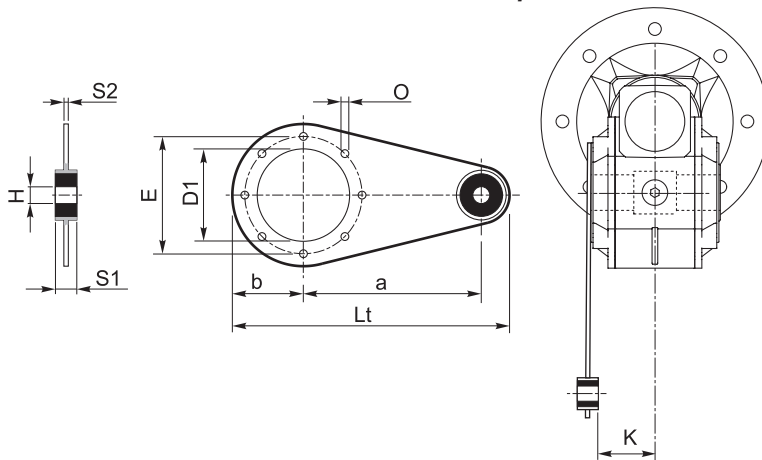

KC	a	b	D <sub>1</sub>	E	H	K	L <sub>t</sub>	O	S <sub>1</sub>	S <sub>2</sub>
30	85	37.5	55	65	8	24	141.5	7	14	4
40	100	45	60	75	10	31.5	167	7	14	4
50	100	50	70	85	10	39	172	9	14	5
63	150	55	80	95	10	49	227	9	14	6
75	200	70	95	115	20	47.5	302	9	25	6
89 - 90	200	80	110	130	20	57.5	312	11	25	6
110	250	100	130	165	25	62	390	11	30	6
130	250	125	180	215	25	69	415	13	30	6

#### Kit di protezione solo su versione P

#### Protection Kit only for P Version

#### Schutzvorrichtung nur für Version P

Albero cavo / Hollow shaft / Hohlwelle

Limitatore di coppia / Torque limiter / Drehmomentbegrenzer

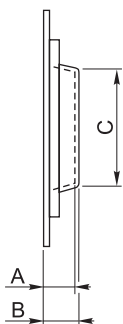

KC	A	B	C
30	12	13	39
40	14	15.5	44
50	15	16.5	54
63	17	19	60
75	18	20	70
89 - 90	21.5	24	80
110	22	25	96
130	22	25	130

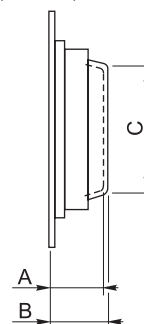

KC	A	B	C
30	36	37	36
40	40	41.5	44
50	47	48.5	53
63	52	54	55
75	58	60	68
89 - 90	60.5	63	70
110	72	75	85
130			

#### Opzioni disponibili:

Cuscinetti a rulli conici corona

#### Available options:

Tapered roller bearing on wormgear

#### Auf Anfrage ist folgendes Zubehör erhältlich:

Kegelrollenlager auf Schneckenrad

**KC**

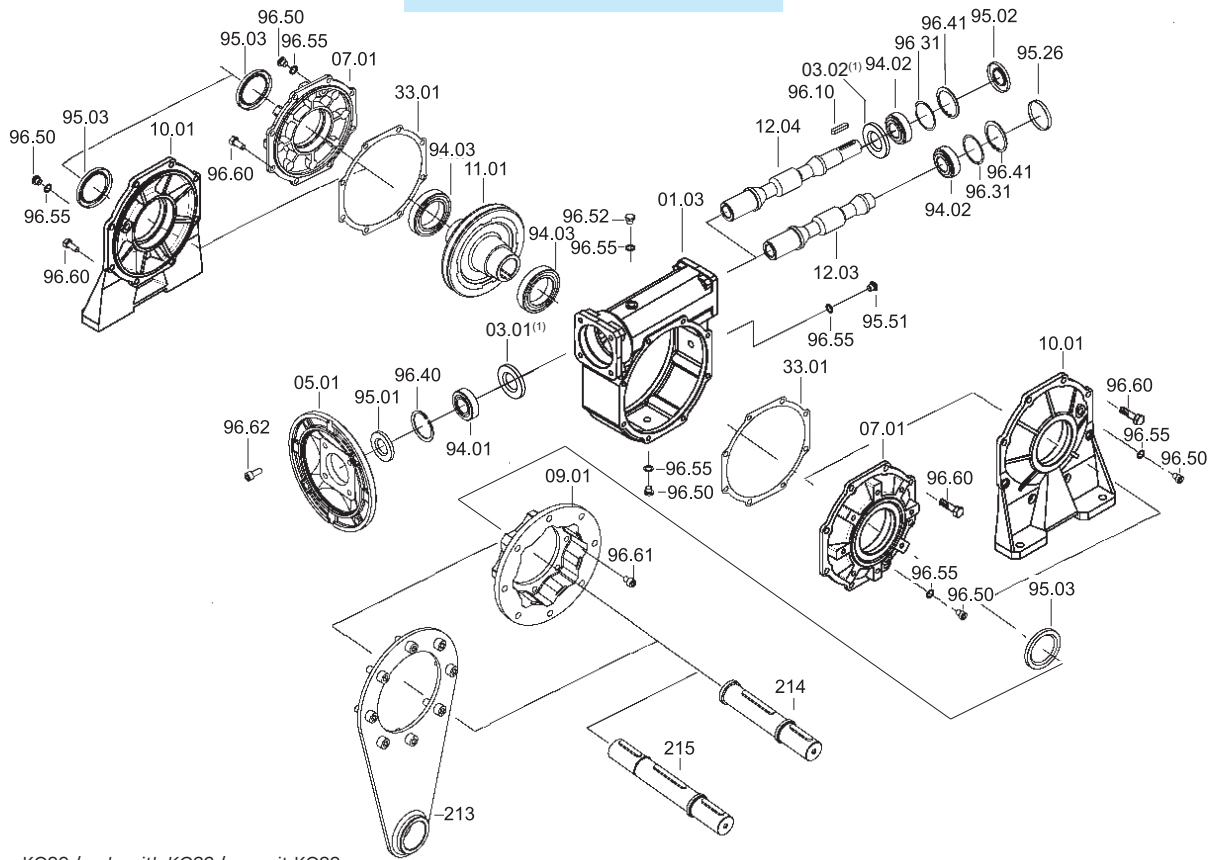

(1): solo con KC89 / only with KC89 / nur mit KC89

KC	IEC	Cuscinetti / Bearings / Lager				Anelli di tenuta / Oilseals Öldichtungen			Cappello / Closed oil seal Geschlossene Öldichtung			
		94.01	94.02	94.03		95.01	95.02	95.03	95.26			
30	56	61804 (20x32x7)	6000	6005	*32005	20/32/7	10/26/7	25/40/7	ø 26x7			
	63	61804 (20x32x7)	10x26x8	25x47x12	25x47x15	20/32/7						
40	56	6303 (17x47x14)	6201	6006	*32006	17/47/7	12/32/7	30/47/7	ø 32x7			
	63	6204 (20x47x14)				12x32x10				30x55x13	30x55x17	20x47x7
	71	6005 (25x47x12)				25/47/7						
50	63	6204 (20x47x14)	6203	6008	*32008	20/47/7	17/40/7	40/62/8	ø 40x7			
	71	6005 (25x47x12)				17x40x12				40x68x15	40x68x19	25/47/7
	80	6006 (30x55x13)										30/55/7
63	71	30305 (25x62x18.25)	30204	6008	*32008	25/62/7	20/47/7	40/62/8	ø 47x7			
	80	30206 (30x62x17.25)				20x47x15.25				40x68x15	40x68x19	30/62/7
	90	32007 (35x62x18)										35/62/7
	71	30206 (30x62x17.25)										30/62/7
75	80	30206 (30x62x17.25)	30205	6010	*32010	30/62/7	25/52/7	50/72/8	ø 52x7			
	90	32007 (35x62x18)				25x52x16.25				50x80x16	50x80x20	35/62/7
	100/112	32008 (40x68x19)										40/68/10
	80	6206 (30x62x16)				6205 C3				6010	*32010	30/62/7
90	6007 (35x62x14)	25x52x15	50x80x16	50x80x20	35/62/7							
100/112	6008 (40x68x15)				40/68/10							
90	80	30206 (30x62x17.25)	32205B	6010	*32010	30/62/7	25/52/7	50/72/8	ø 52x7			
	90	32007 (35x62x18)				25x52x19.25				50x80x16	50x80x20	35/62/7
	100/112	32008 (40x68x19)										40/68/10
110	90	30208 (40x80x19.75)	32206B	6012	*32012	40/80/10	30/62/7	60/85/8	ø 62x7			
	100/112	30208 (40x80x19.75)				30x62x21.25				60x95x18	60x95x23	40/80/10
	132	32010 (50x80x20)										50/80/10
130	90	30208 (40x80x19.75)	33208	6015	*32015	40/80/10	40/80/10	75/100/10	ø 80x10			
	100/112	30208 (40x80x19.75)				40x80x32				75x115x20	75x115x25	40/80/10
	132	32010 (50x80x20)										50/80/10

\* Cuscinetti a rulli conici a richiesta - Tapered roller bearings on request - Auf Wunsch Kegelrollenlager

## Targhetta

## Plate

## Schild

In fase di ordine delle parti di ricambio, specificare sempre n° particolare (vedi disegno esploso), data (1), n° codice (2) e n° variante (3). (Vedi targhetta).

When ordering please specify the spare part number (see exploded view) as well as the date (1), the article number (2) and the variant number (3). (see plate)

Bei der Bestellung von Ersatzteilen sind Ersatzteilnummer (s. Explosionszeichnung), Datum (1), Artikelnummer (2) und Variantenummer (3) anzugeben. (s. Schild)

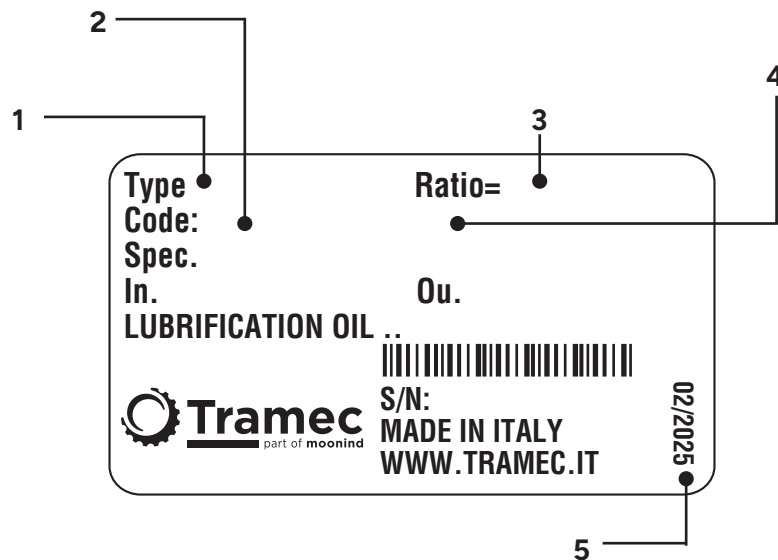

1	TIPO: descrizione	TYPE: description	TYP: Bezeichnung
2	CODICE: distinta base	CODE: base list	ART.-Nr.: Basisstückliste
3	RAP: rapporto di riduzione	RATIO: reduction ratio	ÜBERS: Untersetzungsverhältnis
4	VARIANTE: codice alfanumerico	MODEL: alphanumeric code	VARIANTE: alphanumerische Nummer
5	DATA: mese/anno	DATE: month/year	DATUM: Monat/Jahr



**RIDUTTORI A VITE  
 SENZA FINE CON  
 PRECOPPIA H**
**H HELICAL WORM  
 GEARBOXES**
**STIRNRAD-  
 SCHNECKENGETRIEBE H**
**H**

Caratteristiche	<i>Characteristics</i>	Merkmale	<b>D2</b>
Designazione	<i>Designation</i>	Bezeichnung	<b>D3</b>
Posizioni di montaggio	<i>Mounting position</i>	Einbaulage	<b>D4</b>
Posizione morsettiera	<i>Terminal board position</i>	Lage des Klemmbrett	<b>D4</b>
Lubrificazione	<i>Lubrication</i>	Schmierung	<b>D5</b>
Dati tecnici	<i>Technical data</i>	Technische Daten	<b>D7</b>
Momenti d'inerzia	<i>Moment of inertia</i>	Trägheitsmoment	<b>D14</b>
Dimensioni	<i>Dimensions</i>	Abmessungen	<b>D16</b>
Entrata supplementare	<i>Additional input</i>	Zusatzantrieb	<b>D20</b>
Limitatore di coppia cavo passante	<i>Torque limiter with through hollow shaft</i>	Drehmomentbegrenzer mit durchgehender Hohlwelle	<b>D21</b>
Accessori	<i>Accessories</i>	Zubehör	<b>D22</b>
Lista parti di ricambio	<i>Spare parts list</i>	Ersatzteilliste	<b>D23</b>
Targhetta	<i>Plate</i>	Schild	<b>D24</b>

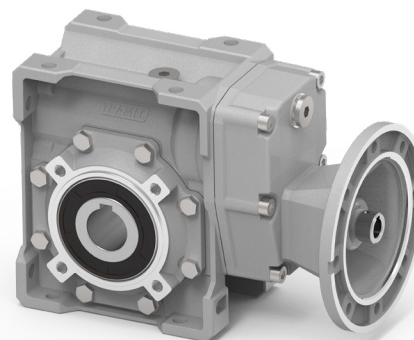
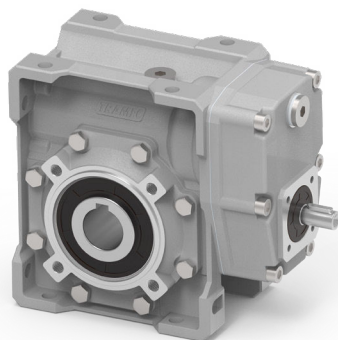
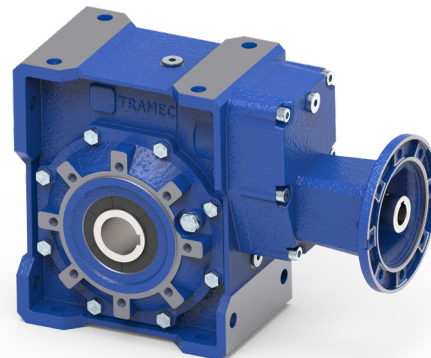
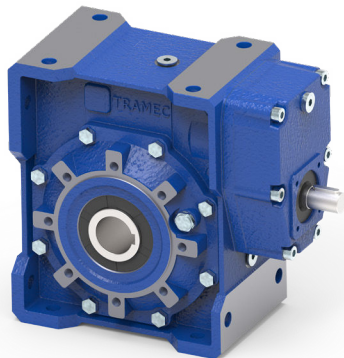

## Caratteristiche

- La serie H presenta le stesse caratteristiche della serie X, ma la presenza della precoppia cilindrica in entrata consente la realizzazione di rapporti più elevati o, a parità di rapporto, rendimenti migliori.
- La struttura è composta dalla carcassa monoblocco del riduttore a vite serie XA sull'entrata del quale è fissato il corpo contenente il primo stadio di riduzione.
- La vite senza fine è in acciaio legato cementato-temprato ed è rettificata.
- Gli ingranaggi della prima riduzione hanno dentatura elicoidale con profilo rettificato.
- La corona ha il mozzo in ghisa con riporto di fusione dell'anello in bronzo.
- Viene fornito l'albero uscita cavo di serie ed esiste un'ampia disponibilità di accessori: seconda entrata, cuscinetti conici sulla corona, flangia uscita, albero lento con 1 o 2 sporgenze, limitatore di coppia con cavo passante, braccio di reazione.
- Le carcasse in ghisa sono verniciate BLU RAL5010 mentre quelle in alluminio sono sabbiato.









## Characteristics

- *The H series has the same characteristics as the X series with the addition of a spur gear pre-stage at input which provides higher ratios or better efficiency under the same ratios.*
- *The structure is composed of a single piece housing for the XA gearbox, at the input side of this gearbox is fitted the housing containing the first stage reduction.*
- *The worm shaft is in case and quench-hardened alloy steel and ground.*
- *The gears of the first reduction have a helical toothing with ground profile.*
- *The worm wheel has a cast-iron hub provided with inserted cast-bronze ring.*
- *Hollow output shaft is supplied as standard. A broad range of accessories is available: second input, tapered roller bearings on the worm wheel, output flange, single or double extended output shaft, torque limiter with through hollow shaft.*
- *Housings in cast-iron are painted BLUE RAL5010, whereas those in aluminium are sandblasted.*

## Merkmale

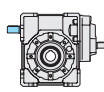
- Die Serie H bietet die gleichen Eigenschaften wie die Serie X. Aufgrund der Stirnrad-Vorstufe bei der Serie H sind jedoch höhere Untersetzungen möglich oder man erhält bei gleichen Untersetzungen einen besseren Wirkungsgrad.
- Diese Ausführung besteht aus dem Blockgehäuse des Schneckengetriebes der Serie XA und einem an den antriebsseitig angebauten Gehäuse, welches die Stirnradvorstufe enthält.
- Die Schnecke ist aus einsatzgehärtetem/abgeschrecktem und daraufhin geschliffenen Legierungsstahl.
- Die Zahnräder der Vorstufe besitzen ein schrägverzahntes Stirnradprofil.
- Das Schneckenrad besteht aus einer Nabe aus Gusseisen und einem aufgeschleuderten Gussbronze-Ring.
- Zahlreiches Zubehör ist lieferbar: zweite Antrieb, Kegelrollenlager auf Schneckenrad, Abtriebsflansch, Standard oder doppelseitig herausragende Abtriebswelle, Drehmomentbegrenzer mit durchgehender Welle, Drehmomentstütze.
- Gehäuse aus Gusseisen werden mit BLAU RAL5010 lackiert, Gehäuse aus Aluminium werden sandgestrahlt.

**Designazione**
**Designation**
**Bezeichnung**

Riduttore Gearbox Getriebe	Tipo entrata Input type Antriebsart	Grandezza Size Größe	Rapporto rid. Ratio Untersetzung	Predispos.att. mot. Motor coupling Motorschluss	Albero uscita cavo Hollow output shaft Abtriebshohlwelle	Limitatore di coppia. Torque limiter Drehmoment- begrenzer	Flangia in uscita. Output flange Abtriebsflansch	Seconda entrata Additional input Zusatzantrieb	Posizione di mont. Mounting position Einbaulage
<b>H</b>	<b>A</b>	<b>50</b>	<b>30/1</b>	<b>P.A.M</b>	<b>H25</b>	<b>LD</b>	<b>F1S</b>	<b>SeA</b>	<b>B3</b>
Riduttore a vite senza fine Wormgearbox Schneckengetriebe	 <b>A</b>	40 50 63 75 90 110 130	30 40 60 80 100 120 160 200 260 320 400	56 63 71 80 90 100 112	vedi tabelle  see tables  siehe Tabellen	 <b>LD</b>	 <b>F1D-F2D-F3D</b>  <b>F1S-F2S-F3S</b>		<b>B3, B6</b> <b>B7, B8</b> <b>V5, V6</b>
	 <b>F</b>					 <b>LS</b>	 <b>F12-F22-F32</b>		

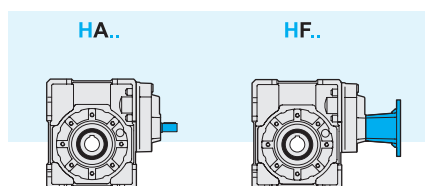
**Tipo entrata**
**Input type**
**Antriebstyp**

**Posizioni di montaggio**

**Mounting positions**

**Montageposition**

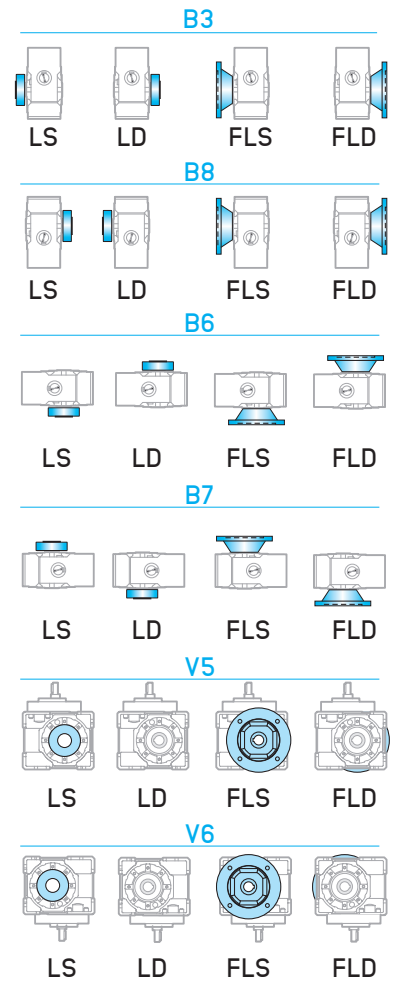
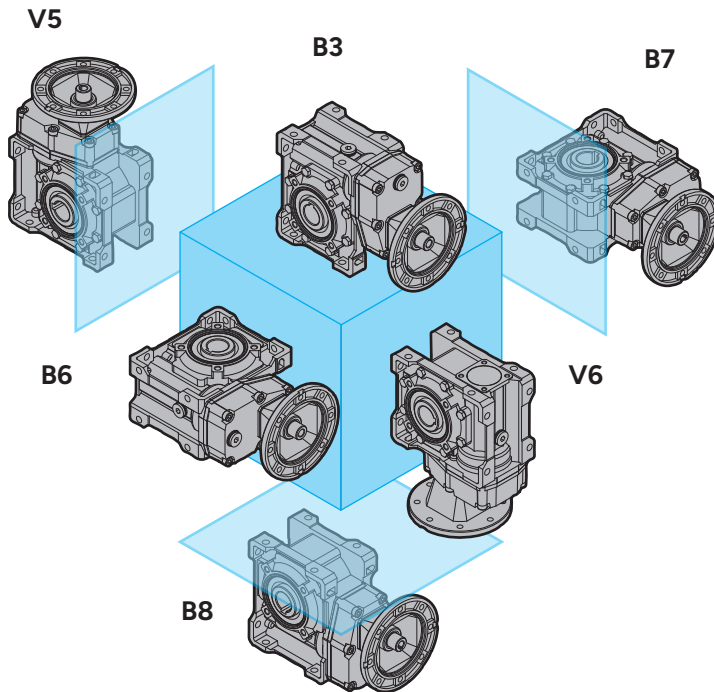

**Posizione morsetteria**

**Terminal board position**

**Lage des Klemmenkastens**

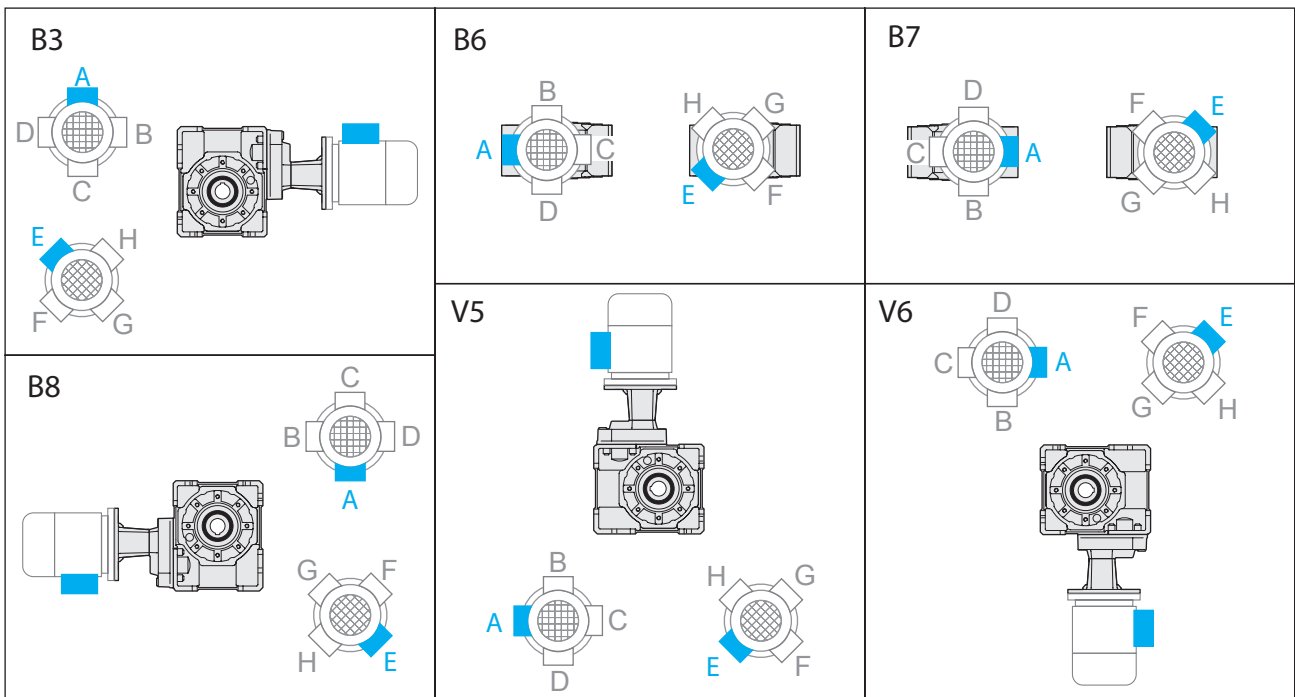

Specificare sempre in fase di ordinazione la posizione di montaggio e la forma costruttiva.  
Posizione morsetteria v. pag. D19 (PM=1; PM=2)

Mounting position always to be specified when ordering.  
Terminal board position see page D19 (PM=1; PM=2)

Bei der Bestellung immer die gewünschte Montageposition und Bauform angeben.  
Lage der Klemmenkaste Seite D19 (PM=1; PM=2)

## Lubrificazione

I riduttori a vite senza fine H sono forniti completi di lubrificante sintetico a base PAG con indice di viscosità ISO VG320. Si raccomanda di precisare sempre in fase di ordine, la posizione di lavoro desiderata.

Per ulteriori dettagli consultare pag. A19 paragrafo "Lubrificazione".

## Lubrication

H worm gearboxes are supplied with PAG synthetic lubricant featuring an ISO VG320 viscosity class. Always specify the required mounting position when ordering.

For more details, see page A19, paragraph "Lubrication".

## Schmierung

Schneckengetriebe der Serie H werden mit synthetischem Schmiermittel auf PAG Basis und Viskosität Index ISO VG320 geliefert. Im Auftrag bitte immer die gewünschte Einbaulage angeben.

Weitere Einzelheiten finden Sie auf Seite A19, Absatz Schmierung.

## Posizione dei tappi e quantità di lubrificante (litri)

## Positions of the plugs and lubricant quantity (liters)

## Position der Kappen und Ölmenge (liter)

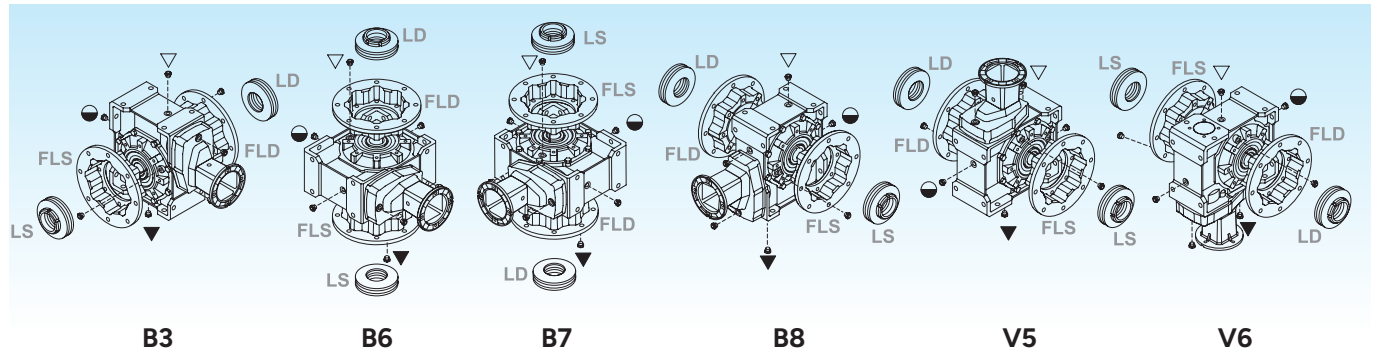

- ▽ Carico e sfiato / Filling and breather  
Einfüll und Entlüftung
- Livello / Level / Ölstand
- ▼ Scarico / Drain / Ablass

Nei corpi in alluminio 40, 50, 63,75 è presente un solo tappo di riempimento olio.

Aluminium housings size 40, 50, 63 and 75 have one filling plug only.

Aluminiumgehäuse in den Größen 40, 50, 63 und 75 verfügen über Einfüllungs-schraube.

**Attenzione!** Nelle versioni HA e HF è indispensabile conoscere la posizione di lavoro in quanto nella configurazione V5 occorre posizionare in modo corretto il paraolio della vite per preservare la corretta lubrificazione della coppia d'ingranaggi cilindrici del primo stadio di riduzione.



**Warning!** It is fundamental to specify the mounting position specially when ordering HA and HF versions. This is because in the V5 configuration the oil seal on the worm shaft must be positioned properly to ensure the lubrication of the spur gearset of the first reduction stage.

**Achtung!** Bei den HA und HF Versionen ist die Information bez. die Einbaulage unbedingt erforderlich: in der V5 Bauform muss der Ölabdichtung auf der Schnecke korrekt eingebaut werden, um die Schmierung des Stirnradsatz der ersten Stufe aufrechtzuhalten.

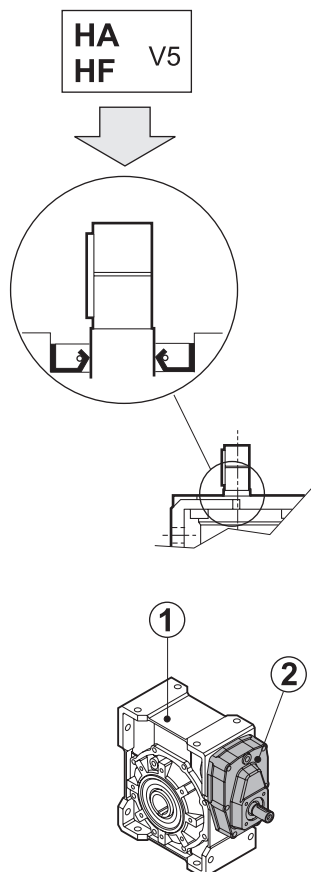



		Q.tà olio / Oil quantity / Schmiermittelmenge [lt]			
		Posizione di montaggio / Mounting position / Einbaulage			
		B3	B6 - B7	B8	V5 - V6
1	40	0.040	0.060	0.040	
	50	0.080	0.120	0.080	
	63	0.160	0.220	0.160	
	75	0.260	0.340	0.260	
	90	1.1	0.9	1	1.5
	110	2.2	1.8	1.6	2.6
130	3.6	3	2.5	3.8	
		B3	B6	B8	V5
2	40	0.040			
	50	0.052			
	63	0.095			
	75	0.180			
	90	0.180			
	110	0.250			
130	0.350				

**Dati tecnici**
**Technical data**
**Technische Daten**

40	$n_1 = 2800$				HA		HF								
	$i_n$	$n_2$ [rpm]	Rd	$P_{t0}$	$T_{2M}$ [Nm]	P [kW]	$T_2$ [Nm]	$P_1$ [kW]	FS'	Input - IEC					
							B5			B14					
 2.9	30	93	0.80	—	52	0.64	30	0.37	1.7	—	63	56	—	63	56
	40	70	0.77		53	0.50	39	0.37	1.4						
	60	47	0.72		53	0.36	37	0.25	1.4						
	80	35	0.70		50	0.26	47	0.25	1.1						
	100	28	0.65		44	0.20	40	0.18	1.1						
	120	23	0.61		55	0.22	45	0.18	1.2						
	160	18	0.57		52	0.17	40	0.13	1.3						
	200	14	0.51		47	0.13	47	0.13	1.0						
	260	11	0.47		42	0.10	38	0.09	1.1						
	320	9	0.45		39	0.08	44	0.09	0.9						
	400	7	0.42		31	0.05	52*	0.09	0.6*						

40	$n_1 = 1400$				HA		HF								
	$i_n$	$n_2$ [rpm]	Rd	$P_{t0}$	$T_{2M}$ [Nm]	P [kW]	$T_2$ [Nm]	$P_1$ [kW]	FS'	Input - IEC					
							B5			B14					
 2.9	30	47	0.77	—	65	0.41	35	0.22	1.9	—	63	56	—	63	56
	40	35	0.75		65	0.32	45	0.22	1.5						
	60	23	0.69		62	0.23	62	0.22	1.0						
	80	18	0.66		60	0.17	47	0.13	1.3						
	100	14	0.61		52	0.12	46	0.11	1.1						
	120	12	0.57		66	0.14	60	0.13	1.1						
	160	9	0.52		62	0.11	62	0.11	1.0						
	200	7	0.47		58	0.09	58	0.09	1.0						
	260	5	0.43		46	0.06	46	0.06	1.1						
	320	4	0.41		44	0.05	53	0.06	0.8						
	400	3	0.38		33	0.03	64*	0.06	0.5*						

40	$n_1 = 900$				HA		HF								
	$i_n$	$n_2$ [rpm]	Rd	$P_{t0}$	$T_{2M}$ [Nm]	P [kW]	$T_2$ [Nm]	$P_1$ [kW]	FS'	Input - IEC					
							B5			B14					
 2.9	30	30	0.76	—	66	0.27	31	0.13	2.1	—	63	56	—	63	56
	40	23	0.73		66	0.21	40	0.13	1.6						
	60	15	0.67		66	0.15	56	0.13	1.2						
	80	11	0.64		66	0.12	49	0.09	1.3						
	100	9	0.59		58	0.09	58	0.09	1.0						
	120	8	0.54		66	0.10	62	0.09	1.1						
	160	6	0.50		66	0.08	51	0.06	1.3						
	200	5	0.44		61	0.06	57	0.06	1.1						
	260	4	0.40		54	0.05	33	0.03	1.6						
	320	3	0.39		46	0.03	39	0.03	1.2						
	400	2	0.36		34	0.02	46*	0.03	0.7*						

40	$n_1 = 500$				HA		HF								
	$i_n$	$n_2$ [rpm]	Rd	$P_{t0}$	$T_{2M}$ [Nm]	P [kW]	$T_2$ [Nm]	$P_1$ [kW]	FS'	Input - IEC					
							B5			B14					
 2.9	30	17	0.74	—	66	0.15	—	—	—	—	63	56	—	63	56
	40	13	0.71		66	0.12	—	—	—						
	60	8	0.66		66	0.09	—	—	—						
	80	6	0.62		66	0.07	—	—	—						
	100	5	0.57		66	0.06	—	—	—						
	120	4	0.52		66	0.06	—	—	—						
	160	3	0.48		66	0.04	—	—	—						
	200	2.5	0.42		66	0.04	—	—	—						
	260	2	0.38		60	0.03	—	—	—						
	320	1.5	0.36		48	0.02	—	—	—						
	400	1	0.34		35	0.01	—	—	—						

\* **ATTENZIONE:** la coppia massima utilizzabile  $[T_{2M}]$  deve essere calcolata utilizzando il fattore di servizio:  
 $T_{2M} = T_2 \times FS'$

\* **WARNING:** Maximum allowable torque  $[T_{2M}]$  must be calculated using the following service factor:  
 $T_{2M} = T_2 \times FS'$

\* **ACHTUNG:** das max. anwendbare Drehmoment  $[T_{2M}]$  muss mit folgendem Betriebsfaktor berechnet werden:  
 $T_{2M} = T_2 \times FS'$

**Dati tecnici**
**Technical data**
**Technische Daten**

50	$n_1 = 2800$				HA		HF								
	$i_n$	$n_2$ [rpm]	Rd	$P_{to}$	$T_{2M}$ [Nm]	P [kW]	$T_2$ [Nm]	$P_1$ [kW]	FS'	Input - IEC					
										B5	B14				
 4.7	30	93	0.81	—	91	1.10	62	0.75	1.5	71	63	56	71	63	—
	40	70	0.79		94	0.87	81	0.75	1.2						
	60	47	0.74		96	0.63	84	0.55	1.1						
	80	35	0.72		94	0.48	72	0.37	1.3						
	100	28	0.68		81	0.35	58	0.25	1.4						
	120	23	0.64		96	0.37	96	0.37	1.0						
	160	18	0.60		97	0.30	81	0.25	1.2						
	200	14	0.55		86	0.23	67	0.18	1.3						
	260	11	0.51		81	0.18	81	0.18	1.0						
	320	9	0.47		72	0.14	67	0.13	1.1						
	400	7	0.44		59	0.10	54	0.09	1.1						

50	$n_1 = 1400$				HA		HF								
	$i_n$	$n_2$ [rpm]	Rd	$P_{to}$	$T_{2M}$ [Nm]	P [kW]	$T_2$ [Nm]	$P_1$ [kW]	FS'	Input - IEC					
										B5	B14				
 4.7	30	47	0.79	0.90	113	0.70	88	0.55	1.3	71	63	56	71	63	—
	40	35	0.76	0.80	116	0.56	116	0.55	1.0						
	60	23	0.71	0.70	116	0.40	108	0.37	1.1						
	80	18	0.68	0.60	114	0.31	93	0.25	1.2						
	100	14	0.63	0.50	97	0.22	97	0.22	1.0						
	120	12	0.59	0.50	107	0.22	107	0.22	1.0						
	160	9	0.55	0.40	115	0.19	108	0.18	1.1						
	200	7	0.50	0.40	102	0.15	89	0.13	1.1						
	260	5	0.46	0.40	90	0.11	90	0.11	1.0						
	320	4	0.42	0.30	83	0.09	83	0.09	1.0						
	400	3	0.40	0.30	65	0.06	65	0.06	0.9						

50	$n_1 = 900$				HA		HF								
	$i_n$	$n_2$ [rpm]	Rd	$P_{to}$	$T_{2M}$ [Nm]	P [kW]	$T_2$ [Nm]	$P_1$ [kW]	FS'	Input - IEC					
										B5	B14				
 4.7	30	30	0.77	—	116	0.47	91	0.37	1.3	71	63	56	71	63	—
	40	23	0.75		116	0.37	116	0.37	1.0						
	60	15	0.69		116	0.26	110	0.25	1.1						
	80	11	0.66		116	0.21	101	0.18	1.2						
	100	9	0.61		108	0.17	85	0.13	1.3						
	120	8	0.57		116	0.16	94	0.13	1.3						
	160	6	0.53		116	0.13	116	0.13	1.0						
	200	5	0.48		112	0.11	91	0.09	1.2						
	260	4	0.44		107	0.09	107	0.09	1.0						
	320	3	0.40		90	0.07	82	0.06	1.1						
	400	2	0.38		65	0.04	48	0.03	1.4						

50	$n_1 = 500$				HA		HF								
	$i_n$	$n_2$ [rpm]	Rd	$P_{to}$	$T_{2M}$ [Nm]	P [kW]	$T_2$ [Nm]	$P_1$ [kW]	FS'	Input - IEC					
										B5	B14				
 4.7	30	17	0.76	—	116	0.27	39	0.09	3.0	71	63	56	71	63	—
	40	13	0.73		116	0.21	50	0.09	2.3						
	60	8	0.67		116	0.15	69	0.09	1.7						
	80	6	0.64		116	0.12	88	0.09	1.3						
	100	5	0.59		116	0.10	101	0.09	1.1						
	120	4	0.54		116	0.09	112	0.09	1.0						
	160	3	0.50		116	0.08	138*	0.09	0.8						
	200	2.5	0.45		116	0.07	156*	0.09	0.7						
	260	2	0.41		114	0.06	184*	0.09	0.6*						
	320	1.5	0.38		95	0.04	208*	0.09	0.5*						
	400	1	0.35		69	0.03	244*	0.09	0.3*						

\* **ATTENZIONE:** la coppia massima utilizzabile [ $T_{2M}$ ] deve essere calcolata utilizzando il fattore di servizio:  
 $T_{2M} = T_2 \times FS'$

\* **WARNING:** Maximum allowable torque [ $T_{2M}$ ] must be calculated using the following service factor:  
 $T_{2M} = T_2 \times FS'$

\* **ACHTUNG:** das max. anwendbare Drehmoment [ $T_{2M}$ ] muss mit folgendem Betriebsfaktor berechnet werden:  
 $T_{2M} = T_2 \times FS'$

**Dati tecnici**
**Technical data**
**Technische Daten**

63	$n_1 = 2800$				HA		HF								
	$i_n$	$n_2$ [rpm]	Rd	$P_{t0}$	$T_{2M}$ [Nm]	P [kW]	$T_2$ [Nm]	$P_1$ [kW]	FS'	Input - IEC					
										B5	B14				
 7.9	30	93	0.82	—	158	1.89	126	1.5	1.3	80	71	63	80	71	—
	40	70	0.80		164	1.50	164	1.5	1.0						
	60	47	0.76		170	1.10	170	1.1	1.0						
	80	35	0.74		181	0.90	151	0.75	1.2						
	100	28	0.71		150	0.62	133	0.55	1.1						
	120	23	0.66		177	0.66	148	0.55	1.2						
	160	18	0.62		186	0.55	186	0.55	1.0						
	200	14	0.57		147	0.37	147	0.37	1.0						
	260	11	0.53		142	0.30	118	0.25	1.2						
	320	9	0.51		138	0.25	138	0.25	1.0						
	400	7	0.46		115	0.18	115	0.18	1.0						

63	$n_1 = 1400$				HA		HF								
	$i_n$	$n_2$ [rpm]	Rd	$P_{t0}$	$T_{2M}$ [Nm]	P [kW]	$T_2$ [Nm]	$P_1$ [kW]	FS'	Input - IEC					
										B5	B14				
 7.9	30	47	0.79	—	198	1.22	146	0.9	1.4	80	71	63	80	71	—
	40	35	0.77		203	0.96	190	0.9	1.1						
	60	23	0.72		203	0.69	163	0.55	1.2						
	80	18	0.70		211	0.55	211	0.55	1.0						
	100	14	0.67		181	0.40	169	0.37	1.1						
	120	12	0.61		213	0.43	185	0.37	1.1						
	160	9	0.57		220	0.35	156	0.25	1.4						
	200	7	0.52		177	0.25	177	0.25	1.0						
	260	5	0.48		175	0.20	154	0.18	1.1						
	320	4	0.46		160	0.16	130	0.13	1.2						
	400	3	0.41		126	0.11	150	0.13	0.8						

63	$n_1 = 900$				HA		HF								
	$i_n$	$n_2$ [rpm]	Rd	$P_{t0}$	$T_{2M}$ [Nm]	P [kW]	$T_2$ [Nm]	$P_1$ [kW]	FS'	Input - IEC					
										B5	B14				
 7.9	30	30	0.78	—	220	0.89	186	0.75	1.2	80	71	63	80	71	—
	40	23	0.76		220	0.69	177	0.55	1.2						
	60	15	0.70		220	0.49	166	0.37	1.3						
	80	11	0.68		220	0.37	220	0.37	1.0						
	100	9	0.65		201	0.29	172	0.25	1.2						
	120	8	0.59		220	0.29	187	0.25	1.2						
	160	6	0.55		220	0.24	168	0.18	1.3						
	200	5	0.50		196	0.18	196	0.18	1.0						
	260	4	0.46		192	0.15	162	0.13	1.2						
	320	3	0.43		175	0.12	133	0.09	1.3						
	400	2	0.39		131	0.08	148	0.09	0.9						

63	$n_1 = 500$				HA		HF								
	$i_n$	$n_2$ [rpm]	Rd	$P_{t0}$	$T_{2M}$ [Nm]	P [kW]	$T_2$ [Nm]	$P_1$ [kW]	FS'	Input - IEC					
										B5	B14				
 7.9	30	17	0.76	—	220	0.50	79	0.18	2.8	80	71	63	80	71	—
	40	13	0.74		220	0.39	101	0.18	2.2						
	60	8	0.68		220	0.28	140	0.18	1.6						
	80	6	0.66		220	0.22	182	0.18	1.2						
	100	5	0.62		220	0.18	220	0.18	1.0						
	120	4	0.56		220	0.17	115	0.09	1.9						
	160	3	0.52		220	0.14	143	0.09	1.5						
	200	2.5	0.47		220	0.12	161	0.09	1.4						
	260	2	0.43		215	0.10	193	0.09	1.1						
	320	1.5	0.41		188	0.08	225	0.09	0.8						
	400	1	0.36		138	0.05	250*	0.09	0.6*						

\* **ATTENZIONE:** la coppia massima utilizzabile  $[T_{2M}]$  deve essere calcolata utilizzando il fattore di servizio:  
 $T_{2M} = T_2 \times FS'$

\* **WARNING:** Maximum allowable torque  $[T_{2M}]$  must be calculated using the following service factor:  
 $T_{2M} = T_2 \times FS'$

\* **ACHTUNG:** das max. anwendbare Drehmoment  $[T_{2M}]$  muss mit folgendem Betriebsfaktor berechnet werden:  
 $T_{2M} = T_2 \times FS'$

**Dati tecnici**
**Technical data**
**Technische Daten**

75	$n_1 = 2800$				HA		HF								
	$i_n$	$n_2$ [rpm]	Rd	$P_{t0}$	$T_{2M}$ [Nm]	P [kW]	$T_2$ [Nm]	$P_1$ [kW]	FS'	Input - IEC					
										B5	B14				
 13.3	30	93	0.82	—	236	2.81	185	2.2	1.3	90	80	71	90	80	—
	40	70	0.80		242	2.20	242	2.2	1.0						
	60	47	0.77		258	1.65	235	1.5	1.1						
	80	35	0.74		285	1.40	223	1.1	1.3						
	100	28	0.72		252	1.03	184	0.75	1.4						
	120	23	0.67		275	1.01	205	0.75	1.3						
	160	18	0.63		290	0.84	259	0.75	1.1						
	200	14	0.60		258	0.63	224	0.55	1.2						
	260	11	0.55		236	0.48	181	0.37	1.3						
	320	9	0.52		214	0.37	214	0.37	1.0						
	400	7	0.48		195	0.30	241	0.37	0.8						

75	$n_1 = 1400$				HA		HF								
	$i_n$	$n_2$ [rpm]	Rd	$P_{t0}$	$T_{2M}$ [Nm]	P [kW]	$T_2$ [Nm]	$P_1$ [kW]	FS'	Input - IEC					
										B5	B14				
 13.3	30	47	0.80	1.9	295	1.80	295	1.8	1.0	90	80	71	90	80	—
	40	35	0.78	1.7	319	1.50	319	1.5	1.0						
	60	23	0.73	1.4	329	1.10	329	1.1	1.0						
	80	18	0.71	1.3	350	0.90	350	0.9	1.0						
	100	14	0.68	1.2	305	0.66	255	0.55	1.2						
	120	12	0.62	1.0	331	0.65	280	0.55	1.2						
	160	9	0.58	0.90	348	0.55	348	0.55	1.0						
	200	7	0.55	0.80	307	0.41	277	0.37	1.1						
	260	5	0.50	0.80	279	0.31	223	0.25	1.3						
	320	4	0.47	0.70	256	0.25	256	0.25	1.0						
	400	3	0.43	0.70	213	0.18	300*	0.25	0.7*						

75	$n_1 = 900$				HA		HF								
	$i_n$	$n_2$ [rpm]	Rd	$P_{t0}$	$T_{2M}$ [Nm]	P [kW]	$T_2$ [Nm]	$P_1$ [kW]	FS'	Input - IEC					
										B5	B14				
 13.3	30	30	0.78	—	338	1.35	275	1.1	1.2	90	80	71	90	80	—
	40	23	0.76		350	1.10	350	1.1	1.0						
	60	15	0.71		343	0.75	343	0.75	1.0						
	80	11	0.69		350	0.60	321	0.55	1.1						
	100	9	0.66		339	0.49	258	0.37	1.3						
	120	8	0.60		350	0.46	281	0.37	1.2						
	160	6	0.56		350	0.37	350	0.37	1.0						
	200	5	0.52		339	0.31	277	0.25	1.2						
	260	4	0.48		307	0.24	233	0.18	1.3						
	320	3	0.45		282	0.18	282	0.18	1.0						
	400	2	0.40		221	0.13	307*	0.18	0.7*						

75	$n_1 = 500$				HA		HF								
	$i_n$	$n_2$ [rpm]	Rd	$P_{t0}$	$T_{2M}$ [Nm]	P [kW]	$T_2$ [Nm]	$P_1$ [kW]	FS'	Input - IEC					
										B5	B14				
 13.3	30	17	0.77	—	350	0.80	110	0.25	3.2	90	80	71	90	80	—
	40	13	0.74		350	0.62	142	0.25	2.5						
	60	8	0.69		350	0.44	198	0.25	1.8						
	80	6	0.67		350	0.34	254	0.25	1.4						
	100	5	0.63		350	0.29	303	0.25	1.2						
	120	4	0.57		350	0.27	325	0.25	1.1						
	160	3	0.53		350	0.22	291	0.18	1.2						
	200	2.5	0.49		350	0.19	348	0.18	1.0						
	260	2	0.45		345	0.16	200	0.09	1.7						
	320	1.5	0.42		303	0.12	231	0.09	1.3						
	400	1	0.38		232	0.08	258	0.09	0.9						

\* **ATTENZIONE:** la coppia massima utilizzabile  $[T_{2M}]$  deve essere calcolata utilizzando il fattore di servizio:  
 $T_{2M} = T_2 \times FS'$

\* **WARNING:** Maximum allowable torque  $[T_{2M}]$  must be calculated using the following service factor:  
 $T_{2M} = T_2 \times FS'$

\* **ACHTUNG:** das max. anwendbare Drehmoment  $[T_{2M}]$  muss mit folgendem Betriebsfaktor berechnet werden:  
 $T_{2M} = T_2 \times FS'$

**Dati tecnici**
**Technical data**
**Technische Daten**

90	$n_1 = 2800$				HA		HF								
	$i_n$	$n_2$ [rpm]	Rd	$P_{t0}$	$T_{2M}$ [Nm]	P [kW]	$T_2$ [Nm]	$P_1$ [kW]	FS'	Input - IEC					
										B5		B14			
 27.2	30	93	0.83	—	381	4.48	255	3	1.5	90	80	71	90	80	—
	40	70	0.82		396	3.56	334	3	1.2						
	60	47	0.78		410	2.57	352	2.2	1.2						
	80	35	0.76		456	2.20	456	2.2	1.0						
	100	28	0.74		416	1.66	377	1.5	1.1						
	120	23	0.69		439	1.54	439	1.5	1.0						
	160	18	0.65		467	1.31	392	1.1	1.2						
	200	14	0.62		427	1.01	317	0.75	1.3						
	260	11	0.58		384	0.75	384	0.75	1.0						
	320	9	0.55		360	0.60	329	0.55	1.1						
400	7	0.50	318	0.47	252	0.37	1.3								

90	$n_1 = 1400$				HA		HF								
	$i_n$	$n_2$ [rpm]	Rd	$P_{t0}$	$T_{2M}$ [Nm]	P [kW]	$T_2$ [Nm]	$P_1$ [kW]	FS'	Input - IEC					
										B5		B14			
 27.2	30	47	0.81	—	482	2.92	297	1.8	1.6	90	80	71	90	80	—
	40	35	0.79		495	2.30	388	1.8	1.3						
	60	23	0.75		506	1.65	460	1.5	1.1						
	80	18	0.72		554	1.40	434	1.1	1.3						
	100	14	0.70		505	1.06	429	0.9	1.2						
	120	12	0.64		531	1.01	473	0.9	1.1						
	160	9	0.60		560	0.85	494	0.75	1.1						
	200	7	0.57		510	0.66	428	0.55	1.2						
	260	5	0.53		454	0.49	345	0.37	1.3						
	320	4	0.50		424	0.39	402	0.37	1.1						
400	3	0.45	367	0.29	314	0.25	1.2								

90	$n_1 = 900$				HA		HF								
	$i_n$	$n_2$ [rpm]	Rd	$P_{t0}$	$T_{2M}$ [Nm]	P [kW]	$T_2$ [Nm]	$P_1$ [kW]	FS'	Input - IEC					
										B5		B14			
 27.2	30	30	0.79	—	550	2.18	379	1.5	1.5	90	80	71	90	80	—
	40	23	0.77		560	1.71	492	1.5	1.1						
	60	15	0.73		560	1.21	510	1.1	1.1						
	80	11	0.70		560	0.94	447	0.75	1.3						
	100	9	0.68		560	0.78	534	0.75	1.1						
	120	8	0.61		560	0.72	430	0.55	1.3						
	160	6	0.58		560	0.57	533	0.55	1.1						
	200	5	0.54		560	0.49	426	0.37	1.3						
	260	4	0.50		501	0.37	501	0.37	1.0						
	320	3	0.47		466	0.29	399	0.25	1.2						
400	2	0.42	381	0.21	320	0.18	1.2								

90	$n_1 = 500$				HA		HF								
	$i_n$	$n_2$ [rpm]	Rd	$P_{t0}$	$T_{2M}$ [Nm]	P [kW]	$T_2$ [Nm]	$P_1$ [kW]	FS'	Input - IEC					
										B5		B14			
 27.2	30	17	0.77	—	560	1.26	111	0.25	5.0	90	80	71	90	80	—
	40	13	0.75		560	0.97	144	0.25	3.9						
	60	8	0.70		560	0.69	202	0.25	2.8						
	80	6	0.68		560	0.54	259	0.25	2.2						
	100	5	0.65		560	0.45	310	0.25	1.8						
	120	4	0.58		560	0.42	334	0.25	1.7						
	160	3	0.54		560	0.34	416	0.25	1.3						
	200	2.5	0.51		560	0.29	488	0.25	1.1						
	260	2	0.47		560	0.24	417	0.18	1.3						
	320	1.5	0.44		517	0.19	485	0.18	1.1						
400	1	0.39	401	0.13	269	0.09	1.5								

\* **ATTENZIONE:** la coppia massima utilizzabile  $[T_{2M}]$  deve essere calcolata utilizzando il fattore di servizio:  
 $T_{2M} = T_2 \times FS'$

\* **WARNING:** Maximum allowable torque  $[T_{2M}]$  must be calculated using the following service factor:  
 $T_{2M} = T_2 \times FS'$

\* **ACHTUNG:** das max. anwendbare Drehmoment  $[T_{2M}]$  muss mit folgendem Betriebsfaktor berechnet werden:  
 $T_{2M} = T_2 \times FS'$

**Dati tecnici**
**Technical data**
**Technische Daten**

110	$n_1 = 2800$				HA		HF								
	$i_n$	$n_2$ [rpm]	Rd	$P_{to}$	$T_{2M}$ [Nm]	P [kW]	$T_2$ [Nm]	$P_1$ [kW]	FS'	Input - IEC					
										B5	B14				
 48.8	30	93	0.84	—	641	7.50	641	7.5	1.0	112 100	90	80	112 100	90	—
	40	70	0.82		658	5.85	619	5.5	1.1						
	60	47	0.79		698	4.30	649	4	1.1						
	80	35	0.77		782	3.71	632	3	1.2						
	100	28	0.75		727	2.83	566	2.2	1.3						
	120	23	0.70		754	2.61	634	2.2	1.2						
	160	18	0.67		807	2.20	807	2.2	1.0						
	200	14	0.65		749	1.70	661	1.5	1.1						
	260	11	0.60		646	1.21	589	1.1	1.1						
	320	9	0.57		611	0.98	469	0.75	1.3						
	400	7	0.53		545	0.75	545	0.75	1.0						

110	$n_1 = 1400$				HA		HF								
	$i_n$	$n_2$ [rpm]	Rd	$P_{to}$	$T_{2M}$ [Nm]	P [kW]	$T_2$ [Nm]	$P_1$ [kW]	FS'	Input - IEC					
										B5	B14				
 48.8	30	47	0.82	3.2	807	4.83	668	4	1.2	112 100	90	80	112 100	90	—
	40	35	0.80	2.9	825	3.78	655	3	1.3						
	60	23	0.76	2.4	864	2.76	689	2.2	1.3						
	80	18	0.74	2.2	957	2.37	887	2.2	1.1						
	100	14	0.72	2.1	884	1.80	884	1.8	1.0						
	120	12	0.66	1.7	916	1.70	809	1.5	1.1						
	160	9	0.62	1.5	970	1.42	749	1.1	1.3						
	200	7	0.60	1.5	896	1.10	896	1.1	1.0						
	260	5	0.55	1.3	743	0.75	743	0.75	1.0						
	320	4	0.52	1.2	722	0.64	624	0.55	1.2						
	400	3	0.47	1.1	644	0.48	705	0.55	0.9						

110	$n_1 = 900$				HA		HF								
	$i_n$	$n_2$ [rpm]	Rd	$P_{to}$	$T_{2M}$ [Nm]	P [kW]	$T_2$ [Nm]	$P_1$ [kW]	FS'	Input - IEC					
										B5	B14				
 48.8	30	30	0.80	—	922	3.61	766	3	1.2	112 100	90	80	112 100	90	—
	40	23	0.78		937	2.82	732	2.2	1.3						
	60	15	0.74		970	2.06	849	1.8	1.1						
	80	11	0.72		970	1.59	912	1.5	1.1						
	100	9	0.69		970	1.32	811	1.1	1.2						
	120	8	0.63		970	1.21	884	1.1	1.1						
	160	6	0.60		970	0.96	758	0.75	1.3						
	200	5	0.57		970	0.81	902	0.75	1.1						
	260	4	0.52		846	0.60	779	0.55	1.1						
	320	3	0.49		794	0.48	616	0.37	1.3						
	400	2	0.45		700	0.37	700	0.37	1.0						

110	$n_1 = 500$				HA		HF								
	$i_n$	$n_2$ [rpm]	Rd	$P_{to}$	$T_{2M}$ [Nm]	P [kW]	$T_2$ [Nm]	$P_1$ [kW]	FS'	Input - IEC					
										B5	B14				
 48.8	30	17	0.78	—	970	2.16	336	0.75	2.9	112 100	90	80	112 100	90	—
	40	13	0.76		970	1.67	437	0.75	2.2						
	60	8	0.72		970	1.18	616	0.75	1.6						
	80	6	0.69		970	0.92	792	0.75	1.2						
	100	5	0.67		970	0.75	970	0.75	1.0						
	120	4	0.60		970	0.71	754	0.55	1.3						
	160	3	0.56		970	0.57	933	0.55	1.1						
	200	2.5	0.53		970	0.48	754	0.37	1.3						
	260	2	0.49		955	0.39	900	0.37	1.1						
	320	1.5	0.46		889	0.32	700	0.25	1.3						
	400	1	0.41		727	0.23	568	0.18	1.3						

\* **ATTENZIONE:** la coppia massima utilizzabile  $[T_{2M}]$  deve essere calcolata utilizzando il fattore di servizio:  
 $T_{2M} = T_2 \times FS'$

\* **WARNING:** Maximum allowable torque  $[T_{2M}]$  must be calculated using the following service factor:  
 $T_{2M} = T_2 \times FS'$

\* **ACHTUNG:** das max. anwendbare Drehmoment  $[T_{2M}]$  muss mit folgendem Betriebsfaktor berechnet werden:  
 $T_{2M} = T_2 \times FS'$

**Dati tecnici**
**Technical data**
**Technische Daten**

130	$n_1 = 2800$				HA		HF						
	$i_n$	$n_2$ [rpm]	Rd	$P_{t0}$	$T_{2M}$ [Nm]	P [kW]	$T_2$ [Nm]	$P_1$ [kW]	FS'	Input - IEC		B14	
										B5			
 60	30	93	0.85	—	976	11.22	652	7.5	1.5	112 100	90	80	—
	40	70	0.84		994	8.67	860	7.5	1.2				
	60	47	0.80		1086	6.63	900	5.5	1.2				
	80	35	0.78		1216	5.71	1171	5.5	1.0				
	100	28	0.78		1170	4.40	1064	4.0	1.1				
	120	23	0.72		1203	4.08	1179	4	1.0				
	160	18	0.70		1306	3.42	1146	3	1.1				
	200	14	0.67		1175	2.57	1005	2.2	1.2				
	260	11	0.64		1008	1.78	851	1.5	1.2				
	320	9	0.61		971	1.46	732	1.1	1.3				
400	7	0.57	889	1.14	855	1.1	1.0						

130	$n_1 = 1400$				HA		HF						
	$i_n$	$n_2$ [rpm]	Rd	$P_{t0}$	$T_{2M}$ [Nm]	P [kW]	$T_2$ [Nm]	$P_1$ [kW]	FS'	Input - IEC		B14	
										B5			
 60	30	47	0.83	4.9	1231	7.3	928	5.5	1.3	112 100	90	80	—
	40	35	0.81	4.4	1238	5.6	1216	5.5	1.0				
	60	23	0.77	3.6	1375	4.3	1279	4	1.1				
	80	18	0.75	3.3	1472	3.7	1194	3	1.2				
	100	14	0.74	3.2	1413	2.8	1111	2.2	1.3				
	120	12	0.68	2.6	1407	2.6	1191	2.2	1.2				
	160	9	0.65	2.4	1517	2.2	1517	2.2	1.0				
	200	7	0.62	2.2	1353	1.6	1269	1.5	1.1				
	260	5	0.58	2	1219	1.1	1219	1.1	1.0				
	320	4	0.55	1.8	1182	0.9	1182	0.9	1.0				
400	3	0.51	1.7	1136	0.7	893	0.55	1.3					

130	$n_1 = 900$				HA		HF						
	$i_n$	$n_2$ [rpm]	Rd	$P_{t0}$	$T_{2M}$ [Nm]	P [kW]	$T_2$ [Nm]	$P_1$ [kW]	FS'	Input - IEC		B14	
										B5			
 60	30	30	0.81	—	1424	5.5	774	3	1.8	112 100	90	80	—
	40	23	0.80		1429	4.2	1019	3	1.4				
	60	15	0.75		1520	3.2	1433	3	1.1				
	80	11	0.72		1694	2.8	1345	2.2	1.3				
	100	9	0.72		1726	2.3	1681	2.2	1.0				
	120	8	0.64		1632	2.0	1508	1.85	1.1				
	160	6	0.61		1723	1.7	1553	1.5	1.1				
	200	5	0.58		1542	1.3	1354	1.1	1.1				
	260	4	0.54		1282	0.87	1102	0.75	1.2				
	320	3	0.51		1298	0.75	1299	0.75	1.0				
400	2	0.47	1126	0.56	1097	0.55	1.0						



130	$n_1 = 500$				HA		HF						
	$i_n$	$n_2$ [rpm]	Rd	$P_{t0}$	$T_{2M}$ [Nm]	P [kW]	$T_2$ [Nm]	$P_1$ [kW]	FS'	Input - IEC		B14	
										B5			
 60	30	17	0.78	—	1659	3.7	335	0.75	4.9	112 100	90	80	—
	40	13	0.76		1616	2.8	435	0.75	3.7				
	60	8	0.72		1786	2.2	619	0.75	2.9				
	80	6	0.70		1819	1.7	802	0.75	2.3				
	100	5	0.69		1821	1.4	988	0.75	1.8				
	120	4	0.61		1816	1.3	1049	0.75	1.7				
	160	3	0.57		1796	1.0	1306	0.75	1.4				
	200	2.5	0.54		1723	0.84	1547	0.75	1.1				
	260	2	0.50		1485	0.60	1366	0.55	1.1				
	320	1.5	0.47		1392	0.48	1063	0.37	1.3				
400	1	0.44	1282	0.38	1244	0.37	1.0						



\* **ATTENZIONE:** la coppia massima utilizzabile  $[T_{2M}]$  deve essere calcolata utilizzando il fattore di servizio:  
 $T_{2M} = T_2 \times FS'$



\* **WARNING:** Maximum allowable torque  $[T_{2M}]$  must be calculated using the following service factor:  
 $T_{2M} = T_2 \times FS'$

\* **ACHTUNG:** das max. anwendbare Drehmoment  $[T_{2M}]$  muss mit folgendem Betriebsfaktor berechnet werden:  
 $T_{2M} = T_2 \times FS'$

**Momenti d'inerzia**
**Moments of inertia**
**Trägheitsmoment**

	$i_n$	HA 	HF 	
			B5 - B14	
			IEC 56	IEC 63
<b>H40</b>	30	0.080	0.125	0.125
	40	0.079	0.123	0.124
	60	0.077	0.122	0.123
	80	0.076	0.120	0.121
	100	0.075	0.120	0.120
	120	0.077	0.121	0.122
	160	0.075	0.120	0.120
	200	0.075	0.120	0.120
	260	0.074	0.119	0.119
	320	0.074	0.119	0.119
	400	0.074	0.119	0.119

	$i_n$	HA 	HF 		
			B5	B5 - B14	
			IEC 56	IEC 63	IEC 71
<b>H50</b>	30	0.161	0.208	0.366	0.383
	40	0.156	0.203	0.361	0.377
	60	0.152	0.199	0.357	0.374
	80	0.148	0.194	0.352	0.369
	100	0.147	0.194	0.352	0.368
	120	0.150	0.197	0.355	0.372
	160	0.146	0.193	0.351	0.368
	200	0.141	0.188	0.346	0.363
	260	0.138	0.185	0.343	0.360
	320	0.138	0.185	0.343	0.360
	400	0.138	0.185	0.343	0.360



	$i_n$	HA 	HF 		
			B5	B5 - B14	
			IEC 63	IEC 71	IEC 80
<b>H63</b>	30	0.405	0.639	0.656	1.219
	40	0.392	0.626	0.643	1.206
	60	0.383	0.617	0.634	1.197
	80	0.364	0.598	0.615	1.178
	100	0.362	0.596	0.613	1.176
	120	0.377	0.612	0.628	1.191
	160	0.361	0.595	0.612	1.175
	200	0.360	0.595	0.611	1.175
	260	0.354	0.588	0.605	1.168
	320	0.354	0.588	0.605	1.168
	400	0.354	0.588	0.605	1.168



 Momenti d'inerzia [kg·cm<sup>2</sup>]  
 riferiti all'albero veloce in entrata

 Moments of inertia [kg·cm<sup>2</sup>]  
 referred to input shaft

 Trägheitsmoment [kg·cm<sup>2</sup>]  
 bez. Antriebswelle

**Momenti d'inerzia**
**Moments of inertia**
**Trägheitsmoment**

	$i_n$	HA 	HF 		
			B5	B5 - B14	
			IEC 71	IEC 80	IEC 90
<b>H75</b>	30	0.865	1.643	1.778	2.855
	40	0.835	1.613	1.748	2.825
	60	0.813	1.592	1.726	2.804
	80	0.777	1.556	1.690	2.768
	100	0.773	1.551	1.686	2.764
	120	0.801	1.579	1.714	2.791
	160	0.770	1.548	1.683	2.760
	200	0.769	1.547	1.682	2.759
	260	0.751	1.530	1.664	2.742
	320	0.751	1.530	1.664	2.742
	400	0.751	1.529	1.664	2.742



	$i_n$	HA 	HF 		
			B5	B5 - B14	
			IEC 71	IEC 80	IEC 90
<b>H90</b>	30	1.064	1.843	1.977	3.055
	40	1.000	1.779	1.913	2.991
	60	0.955	1.733	1.868	2.945
	80	0.845	1.623	1.758	2.835
	100	0.836	1.615	1.749	2.827
	120	0.927	1.706	1.840	2.918
	160	0.829	1.608	1.742	2.820
	200	0.827	1.606	1.740	2.818
	260	0.784	1.562	1.696	2.774
	320	0.783	1.562	1.696	2.774
	400	0.783	1.561	1.695	2.773

Momenti d'inerzia [kg·cm<sup>2</sup>]  
 riferiti all'albero veloce in entrata



Moments of inertia [kg·cm<sup>2</sup>]  
 referred to input shaft

Trägheitsmoment [kg·cm<sup>2</sup>]  
 bez. Antriebswelle

**Momenti d'inerzia**
**Moments of inertia**
**Trägheitsmoment**

	$i_n$	HA 	HF 		
			B5	B5 - B14	
			IEC 80	IEC 90	IEC 110-112
<b>H110</b>	30	2.558	4.726	4.654	6.424
	40	2.379	4.547	4.475	6.246
	60	2.251	4.420	4.347	6.118
	80	1.958	4.127	4.054	5.825
	100	1.933	4.102	4.029	5.800
	120	2.175	4.343	4.271	6.041
	160	1.915	4.084	4.011	5.782
	200	1.909	4.077	4.005	5.776
	260	1.779	3.948	3.875	5.646
	320	1.778	3.946	3.874	5.645
	400	1.777	3.945	3.873	5.644

	$i_n$	HA 	HF 		
			B5		
			IEC 80	IEC 90	IEC 110-112
<b>H130</b>	30	5.64	7.90	10.22	11.83
	40	5.15	7.42	9.73	11.35
	60	4.81	7.07	9.39	11.00
	80	4.15	6.41	8.72	10.34
	100	4.07	6.34	8.65	10.27
	120	4.60	6.86	9.18	10.79
	160	4.03	6.29	8.61	10.22
	200	4.01	6.27	8.59	10.20
	260	3.75	6.01	8.32	9.94
	320	3.74	6.00	8.32	9.93
	400	3.74	6.00	8.32	9.93

Momenti d'inerzia [kg·cm<sup>2</sup>]  
 riferiti all'albero veloce in entrata

Moments of inertia [kg·cm<sup>2</sup>]  
 referred to input shaft

Trägheitsmoment [kg·cm<sup>2</sup>]  
 bez. Antriebswelle

Dimensioni

Dimensions

Abmessungen

**HA**

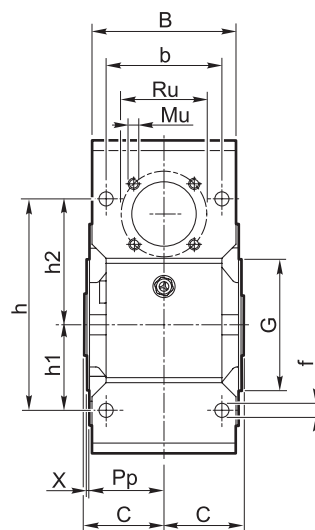
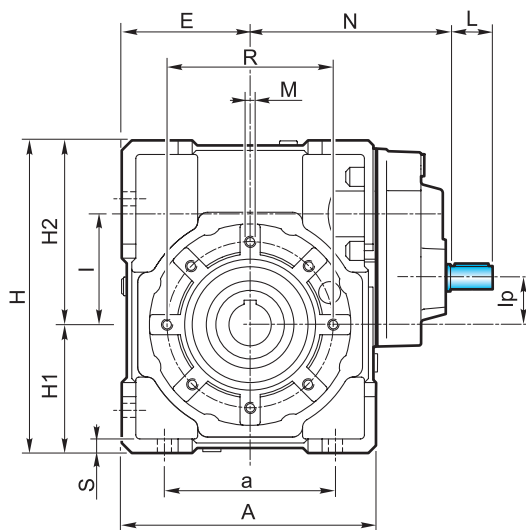

**HF**

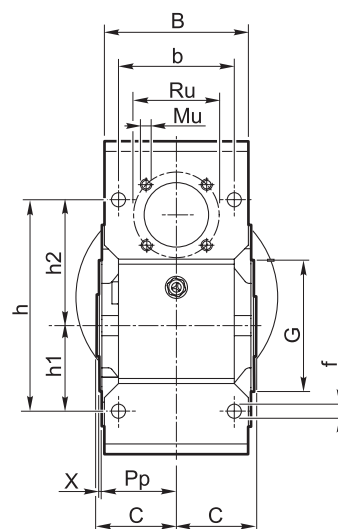
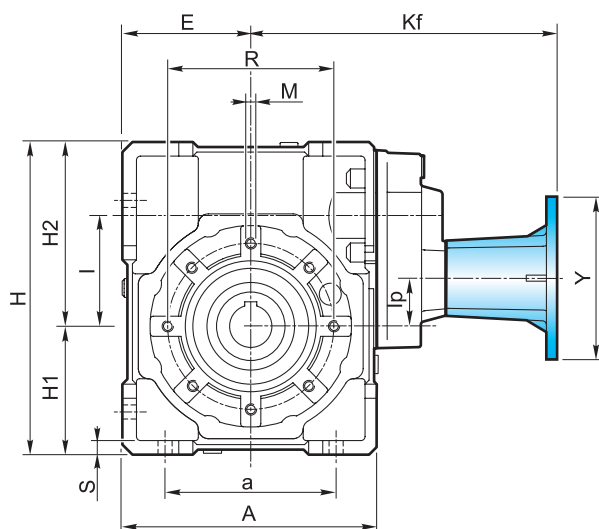

**Dimensioni**
**Dimensions**
**Abmessungen**

Flangia pendolare / Shaft-mounted flange / Aufsteckflansch

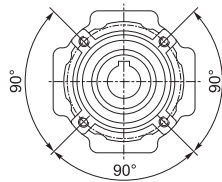
**40 - 50**

4 Fori / Holes / Bohrungen

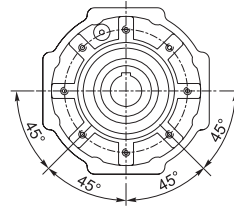
**63 - 75 - 90 - 110 - 130**

8 Fori / Holes / Bohrungen

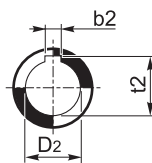
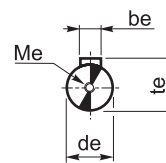
 Albero uscita cavo  
 Output hollow shaft  
 Abtriebshohlwelle

 Albero entrata  
 Input shaft  
 Antriebswelle

H	A	a	B	b	b <sub>e</sub>	b <sub>2</sub>	C	d <sub>e</sub> j6	D <sub>2</sub> H8	E	f	G h8	H	H <sub>1</sub>	H <sub>2</sub>	h	h <sub>1</sub>	h <sub>2</sub>	
40	105	70	71	60	3	6	6	9	18	19	50	6.5	60	125	50	75	90	35	55
50	125	80	85	70	4	8	8	11	25	24	60	8.5	70	150	60	90	104	40	64
63	147	100	103	85	5	8	—	14	25	—	72	9	80	182	72	110	130	50	80
75	176	120	112	90	6	8	8	19	28	30	86	11	95	219.5	86	133.5	153	60	93
90	203	140	130	100	6	10	10	19	35	32	103	13	110	248.5	103	145.5	172	70	102
110	252.5	170	143	115	8	12	—	24	42	—	127.5	14	130	310.5	127.5	183	210	85	125
130	292.5	200	155	120	8	14	14	24	45	48	147.5	15	180	355	147.5	207.5	240	100	140

H	I	I <sub>p</sub>	L	M	M <sub>e</sub>	M <sub>u</sub>	N	P <sub>p</sub>	R	R <sub>u</sub>	S	t <sub>e</sub>	t <sub>2</sub>	X
40	40	5	15	M6X10	M4X12	M5X10	91.5	36.5	75	42.4	6	10.2	20.8	21.8
50	50	10	20	M8x10	M4x12	M6x10	104.5	43.5	85	53.7	7	12.5	28.3	27.3
63	63	16.5	25	M8x14	M4x10	M6x12	121	53	95	60.8	8	16	28.3	—
75	75	22	30	M8x14	M6x16	M8x12	147.75	57	115	70.7	10	21.5	31.3	33.3
90	90	37	30	M10x18	M6x16	M8x14	157.75	67	130	70.7	12	21.5	38.3	35.3
110	110	47	40	M10x18	M8x22	M10x18	196.5	74	165	85.0	14	27	45.3	—
130	130	55	50	M12x20	M8x14	M10x16	240	81	215	104	15	27	48.8	51.8

Dimensioni attacco flangia entrata

Dimensions of the input mounting flange

Abmessungen des Eintriebsflansches

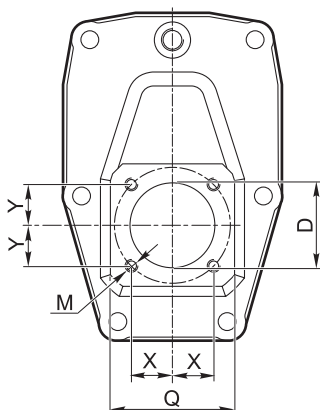

H	D	M	Q	X	Y
40	26	M5x9	40	12.5	12.5
50	32	M5x9	45	15	15
63	40	M6x12	53	19	19
75	47	M6x12	62	21.5	21.5
90	47	M6x12	62	21.5	21.5
110	52	M8x15	75	25	25
130	62	M10x17	92	30	30

**Dimensioni**

**Dimensions**

**Abmessungen**

Flangia uscita / Output flange / Abtriebsflansch

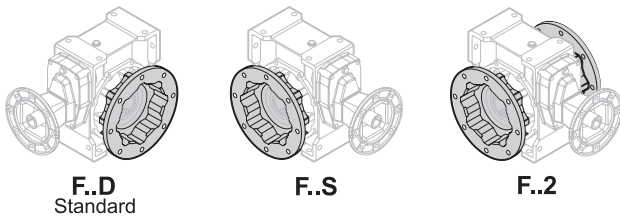
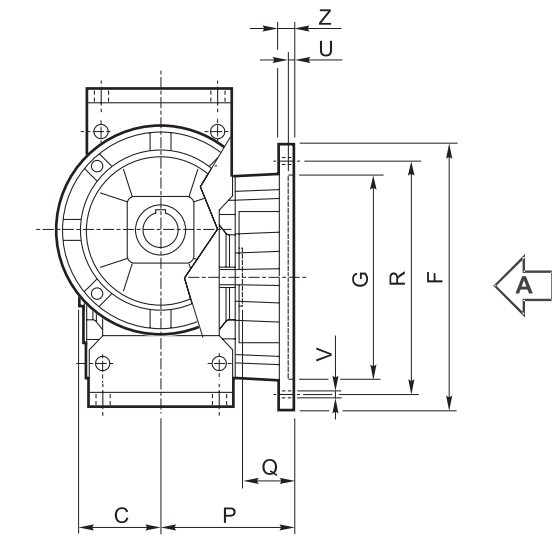

Vista da A / View from A / Ansicht von A

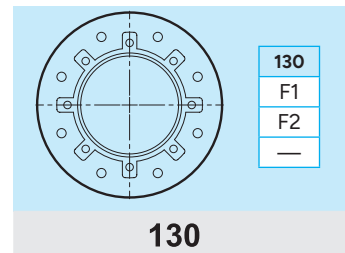
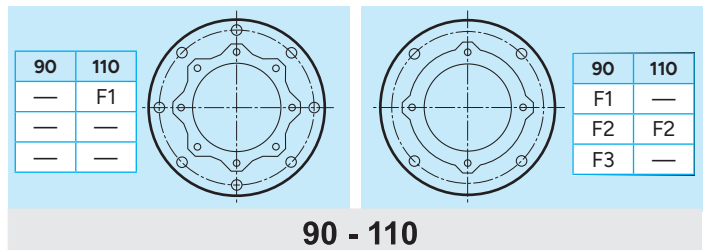
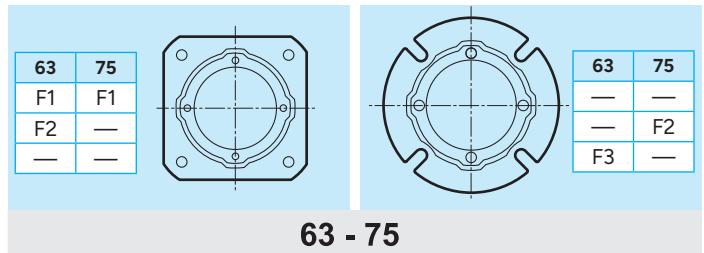
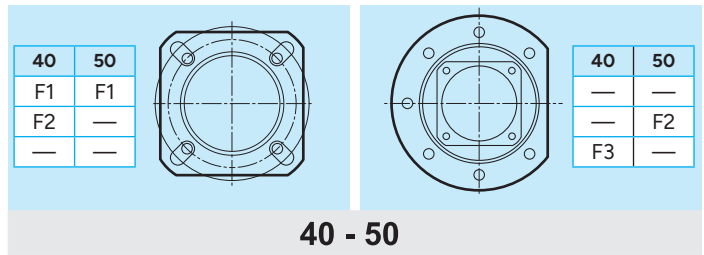

Tipo Type Typ	C	F		G H8	P	Q	R	U	V			Z	
											Ø		
40	F1	39		85	60	67	28	75-90	4	n° 4	9	8	
	F2			85	60	97	58	75-90	4	n° 4	9	8	
	F3			140	95	80	41	115	5		n° 7	9	10
50	F1	46		94	70	90	44	85-100	5	n° 4	11	10	
	F2			160	110	89	43	130	5		n° 7	11	11
	F3												
63	F1	56		142	115	82	26	150	5	n° 4	11	11	
	F2			142	115	112	56	150	5	n° 4	11	11	
	F3			160	110	80.5	24.5	130	5	n° 4	11	12	
75	F1	60		160	130	111	51	165	5	n° 4	13	12	
	F2			160	110	90	30	130	6	n° 4	11	13	
	F3												
90	F1	70		200	152	111	41	175	5	n° 4	13	12	
	F2			200	152	151	81	175	5	n° 4	13	13	
	F3			200	130	110	40	165	6	n° 4	11	11	
110	F1	77.5		260	170	131	53.5	230	6		n° 8	13	15
	F2			250	180	150	72.5	215	5	n° 4	15	16	
	F3												
130	F1	85		320	180	140	55	255	7		n° 8 *	16	16
	F2			300	230			265					
	F3												

\* Foratura ruotata di 22.5°

\* Drilling turned of 22.5°

\* Durchbohrung 22.5° versetzt

**Dimensioni**

**Dimensions**

**Abmessungen**

Flangia entrata / Input flange / Antriebsflansch

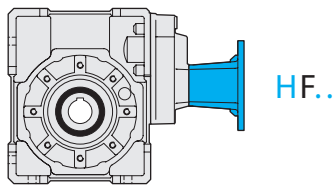

HF..

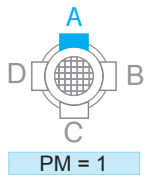

PM = 1

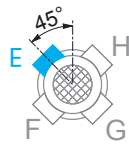

PM = 2

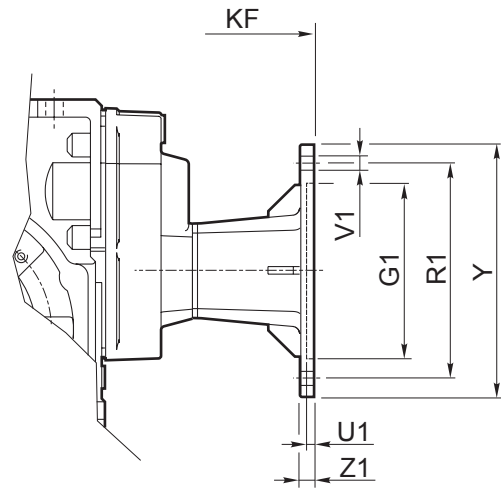

HF	IEC	PM		G <sub>1</sub>	K <sub>F</sub>	R <sub>1</sub>	U <sub>1</sub>	∅	V <sub>1</sub>			Y	Z <sub>1</sub>
		1	2										
40	56 B5	•	•	80	129.5	100	3.5	7		8		120	8
	56 B14		•	50	129.5	65	3.5	6			4	80	8
	63 B5	•	•	95	132.5	115	4	9		8		140	10
	63 B14	•	•	60	132.5	75	3.5	6		8		90	8
50	56 B5	•	•	80	148.5	100	3.5	7		8		120	8
	63 B5	•	•	95	151.5	115	4	9		8		140	10
	63 B14	•	•	60	151.5	75	3.5	6		8		90	8
	71 B5	•	•	110	158.5	130	4.5	9		8		160	10
	71 B14	•	•	70	158.5	85	4	7		8		105	10
63	63 B5	•	•	95	173	115	4	9		8		140	10
	71 B5	•	•	110	180	130	4.5	9		8		160	10
	71 B14		•	70	180	85	3.5	7			4	105	10
	80 B5	•	•	130	190	165	4.5	11		8		200	10
	80 B14	•	•	80	190	100	4	7		8		120	10
75	71 B5	•	•	110	221.5	130	4.5	9		8		160	10
	80/90 B5	•	•	130	232	165	4.5	11		8		200	10
	80 B14	•	•	80	222	100	4	7		8		120	10
	90 B14	•	•	95	232	115	4	9		8		140	10
90	71 B5	•	•	110	221.5	130	4.5	9		8		160	10
	80/90 B5	••	•	130	242	165	4.5	11		8		200	10
	80 B14	•	•	80	232	100	4	7		8		120	10
	90 B14	•	•	95	242	115	4	9		8		140	10
110	80/90 B5	•	•	130	294.5	165	4.5	11		8		200	10
	90 B14		•	95	294.5	115	4	9			4	140	10
	100/112 B5	•	•	180	304.5	215	5	14		8		250	14
	100/112 B14	•	•	110	304.5	130	4.5	9		8		160	10
130	80/90 B5	•	•	130	345.5	165	4.5	11	4			200	12
	100/112 B5	•	•	180	355.5	215	5	14	4			250	14

N.B.: Il montaggio STD di P<sub>M</sub>=2 solo quando non è possibile il montaggio STD di P<sub>M</sub>=1.

N.B.: STD mounting of P<sub>M</sub>=2 only if STD mounting of P<sub>M</sub>=1 is not possible.

ANMERKUNG: STD Montage von P<sub>M</sub>=2 nur wenn STD Montage von P<sub>M</sub>=1 unmöglich ist.

## Entrata supplementare (Vite bisporgente)

## Additional input (double extended shaft)

## Zusatzantrieb (beidseitige Welle)

S.e.A.

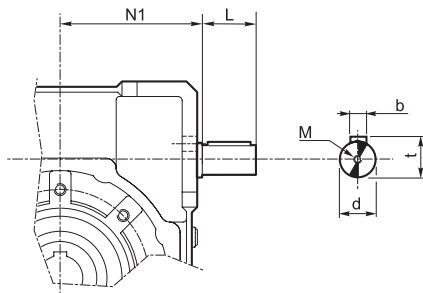

**NOTA:** L'entrata supplementare nella serie H si trova nella posizione intermedia del cinematismo. Quindi, se utilizzata come comando, avrà la sola riduzione della coppia vite/corona. Se invece viene utilizzata come asse condotto, la sua velocità sarà quella in entrata ridotta dal rapporto 4:1 della precoppia.

**NOTE:** the second shaft of the H series gearboxes is placed in the intermediate position of the kinematic motion which if used as a drive will have only the reduction of the worm/wheel set. For the utilization as a driven shaft its speed will correspond to the input speed reduced by the ratio 4:1 of the pre-stage.

**BEMERKUNG:** das zweite Wellenende der Getriebe der Serie H befindet sich in der Mitte des Getriebes. Falls das zweite Wellenende als zusätzliche Antriebswelle genutzt werden, muss aufgrund der Vorstufe mit einer um 4:1 reduzierte Drehzahl eingetrieben werden.

H	d j6	L	M	N1	b	t
40	11	20	M4x12	52.5	4	12.5
50	14	25	M5x13	62.5	5	16
63	19	30	M8x20	74.5	6	21.5
75	24	40	M8x20	91	8	27
90	24	40	M8x20	108	8	27
110	28	50	M8x20	132.5	8	31
130	38	70	M10x25	152	10	41

## Limitatore di coppia cavo passante

## Torque limiter with through hollow shaft

## Drehmomentbegrenzer mit durchgehender Hohlwelle

Il limitatore di coppia viene consigliato in tutte quelle applicazioni che richiedono una limitazione sulla coppia trasmissibile per proteggere l'impianto e/o preservare il riduttore evitando sovraccarichi o urti indesiderati quanto inaspettati. È un dispositivo con albero dotato di cavo passante, con funzionamento a frizione, ed è integrato al riduttore, presentando un ingombro limitato. Concepito per lavorare a bagno d'olio, il dispositivo risulta affidabile nel tempo ed è esente da usura se non viene mantenuto in condizioni prolungate di slittamento (condizione che si verifica quando la coppia presenta valori superiori a quelli di taratura). La taratura è facilmente regolabile dall'esterno attraverso il serraggio di una ghiera autobloccante che porta a compressione le 4 molle a tazza disposte tra loro in serie. Il dispositivo non consente:

- l'impiego di cuscinetti a rulli conici in uscita
- funzionamento prolungato in condizioni di slittamento.

Nella tabella seguente vengono riportati i valori delle coppie di slittamento  $M_{2S}$  in funzione del n° di giri della ghiera. I valori di taratura presentano una tolleranza del  $\pm 10\%$  e si riferiscono ad una condizione statica. In condizioni dinamiche è da notare che la coppia di slittamento assume valori diversi a seconda del tipo e/o modalità in cui si verifica il sovraccarico: con valori maggiori in caso di carico uniformemente crescente rispetto a valori più contenuti in seguito al verificarsi di picchi improvvisi di carico.

**NOTA:** quando si supera il valore di taratura si ha slittamento. Il coefficiente di attrito tra le superfici di contatto da statico diventa dinamico e la coppia trasmessa cala del 30% circa. È quindi opportuno prevedere uno stop per poter ripartire al valore di taratura iniziale.

The use of a torque limiter is advisable in case of applications requiring the limitation of the torque in order to safeguard the plant and/or the gearbox against unexpected and undesired overloads or shocks. The torque limiter is equipped with a through hollow shaft and friction clutch. It is integrated in the gearbox, space requirement is therefore limited. Designed to work in oil bath, it is reliable over time and is not subject to wear unless prolonged slipping occurs (it happens when the torque values are higher than the calibration values). Calibration can be easily adjusted from the outside by tightening the self-locking ring nut, which causes the compression of 4 Belleville washers arranged in series.

The use of the torque limiter does not go together with:

- the use of tapered roller bearings at output
- Prolonged operation under slipping conditions.

The following table shows the values of  $M_{2S}$  slipping torques depending on the number of revolutions of the ring nut. Calibration values feature a  $\pm 10\%$  tolerance and refer to static conditions. Under dynamic conditions, the values of the slipping torque differ depending to the type of overload: the values are higher if the load increase is uniform, the values are lower if sudden load peaks occur.

**NOTE:** Slipping occurs when the setting values are exceeded. The friction coefficient between the contact surfaces from static becomes dynamic and the transmitted torque is approx. 30% lower. It is advisable to have a stop first in order to have a restart based on the initial setting value.

Die Anwendung eines Drehmomentbegrenzers wird empfohlen, um die Anlage und das Getriebe gegen unerwünschte und unerwartete Überbelastungen und Stößen zu schützen. Der Begrenzer verfügt über eine durchgehende Hohlwelle und eine Kupplung. Er ist in dem Getriebe integriert, d.h. der Raumbedarf ist klein. Der Drehmomentbegrenzer wurde für Betrieb in Ölbad entworfen. Er ist zuverlässig über Zeit und verschleißfest (ausser wenn Rutschen für lange Zeit besteht: das passiert, wenn das Drehmoment höher als der Eichwert ist). Die Eichung darf müheles von aussen durch das Anziehen einer selbstsperrenden Mutter ausgeführt werden. Das Anziehen verursacht die Zusammendrückung der 4 wechsellagerbaren schichteten Tellerfeder. Der Drehmomentbegrenzer sieht das folgende nicht vor:

- die Verwendung von Kegelrollenlager am Abtrieb
- Längerer Rutschbetrieb.

Die nachstehende Tabelle zeigt die Werte der Rutschmomente  $M_{2S}$  abhängig von der Zahl der Umdrehungen der Mutter.

Die Eichwerte weisen  $\pm 10\%$  Toleranz auf und beziehen sich auf statische Bedingungen.

Unter dynamischen Bedingungen hat das Rutschmoment verschiedene Werte je nach Art der Überbelastung. Die Werte sind höher, wenn die Belastung gleichmäßig zunimmt; sie sind niedriger im Falle von plötzlichen Belastungsspitzen.

**BEMERKUNG:** Rutschen tritt auf, wenn die eingestellten Werte überschritten werden. Der Reibungskoeffizient zwischen den Berührungsflächen wird dynamisch anstatt statisch und das übertragene Drehmoment sinkt um ca. 30%. Es ist daher ratsam, vor dem erneuten Anfahren anzuhalten, um die ursprünglichen Drehmomentwerte zu erreichen.

### Limitatore di coppia cavo passante

È importante notare che la coppia di slittamento non resta sempre la medesima durante tutta la vita del limitatore.  
Tende infatti a diminuire in rapporto al numero e alla durata degli slittamenti che, rodando le superfici di contatto, ne aumentano il rendimento.  
È quindi opportuno verificare periodicamente, soprattutto durante la fase di rodaggio, la taratura del dispositivo.  
Là dove sia richiesto un errore più contenuto nella taratura, è necessario testare la coppia trasmissibile sull'impianto.  
Il dispositivo viene consegnato tarato alla coppia riportata a catalogo  $T_{2M}$  salvo diversa indicazione espressa in fase di ordinazione.

### Torque limiter with through hollow shaft

It is important to note that the slipping torque is not the same for the entire life of the torque limiter. It usually decreases in connection with the number and the duration of slippings, this is due to the surfaces of the torque limiter becoming more engaged, therefore increasing the efficiency.  
For this reason it is advisable to check the calibration of the device at regular intervals, specially during the running-in period.  
Should a smaller calibration error be required, it is necessary to test the transmissible torque on the plant.  
The torque limiter is supplied already calibrated at the torque value reported in the catalogue  $T_{2M}$ , unless otherwise specified on the order.

### Drehmomentbegrenzer mit durchgehender Hohlwelle

Es ist wichtig zu beachten, dass das Rutschmoment der Rutschkupplung über die gesamte Lebensdauer nicht konstant bleibt, sondern üblicherweise in Verbindung mit längeren Rutschzyklen aufgrund der eingelaufenen Berührungsflächen abnimmt.  
Deswegen ist es ratsam, die Einstellung der Vorrichtung besonders während der Einlaufzeit in regelmäßigen Zeitabständen zu prüfen.  
Wenn der Drehmomentbegrenzer geliefert wird, ist dieser schon auf dem im Katalog unter  $T_{2M}$  angegebenen Wert eingestellt, außer wenn es in der Bestellung anders angegeben wird.

H	N°. giri della ghiera di regolazione / N°. revolutions of ring nut / Nr. Umdrehungen der Mutter															
	1 1/4	1 1/2	1 3/4	2	2 1/4	2 1/2	2 3/4	3	3 1/4	3 1/2	3 3/4	4	4 1/4	4 1/2	4 3/4	5
	$M_{25}$ [Nm]															
40	35	40	45	50	55	60	65									
50	60	70	80	90	100	110	115	120								
63				115	125	130	140	155	165	175	180	190	200	220		
75		220	245	275	310	350										
90	250	290	330	365	410	435	465	500	530	560	580					
110	500	560	670	730	810	910	940	970								
130																

Disposizione delle molle  
Washers' arrangement  
Lage der Feder

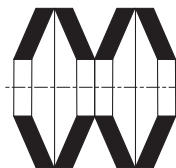

**IN SERIE** (min. coppia, max. sensibilità)  
**SERIES** (min. torque, max sensitivity)  
**SERIE** (min. Moment, max. Empfindlichkeit)

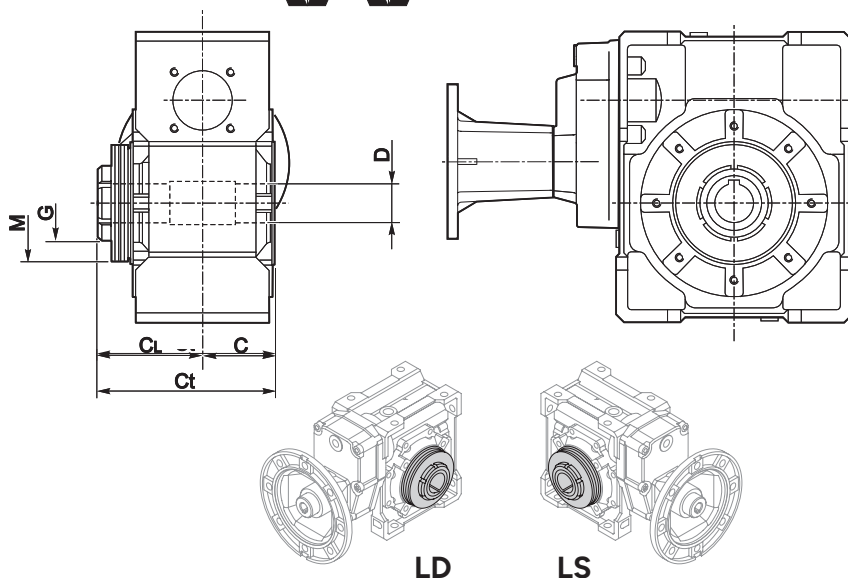

H	C	C <sub>L</sub>	C <sub>t</sub>	D <sub>H8</sub>	M	G
40	39	65	104	18 (19)	56x30.5x1.5	M30x1.5
50	46	76	122	25 (24)	63x40.5x1.8	M40x1.5
63	56	91	147	25	71x40.5x2	M40x1.5
75	60	100	160	28 (30)	90x50.5x3.5	M50x1.5
90	70	109	179	35 (32)	100x51x2.7	M50x1.5
110	77.5	127.5	205	42	125x61x4	M60x2.0
130						

( ) A richiesta / On request / Auf Anfrage

Nella versione con limitatore non è prevista la fornitura degli alberi lenti.

The version with torque limiter is supplied without output shafts.

Die Version mit Drehmomentbegrenzer wird ohne Abtriebswellen geliefert.

**Accessori**
**Albero lento**

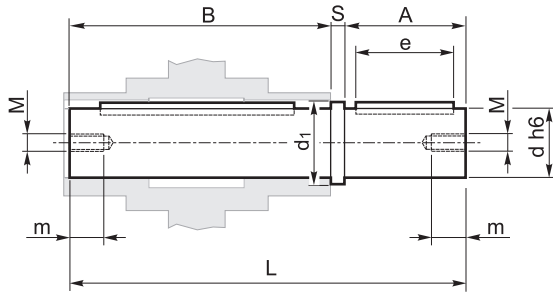
 Albero lento semplice  
 Single output shaft  
 Standard Abtriebswelle

X	A	B	d <sub>h6</sub>		d <sub>1</sub>	e	L	M	m	S
40	40	77	18	19	23.5	30	120	M6	16	3
50	50	90	25	24	31.5	40	143.5	M8	22	3.5
63	50	111	25	31.5	40	165	M8	22	4	
75	60	119	28	30	34.5	50	183	M8	22	4
90	80	139	35	41.5	60	224	M10	28	5	
110	80	154.5	42	49.5	60	242.5	M10	28	8	
130	80	168	45	54.5	70	253	M16	36	5	

**Accessories**
**Output shaft**
**Zubehör**
**Abtriebswelle**

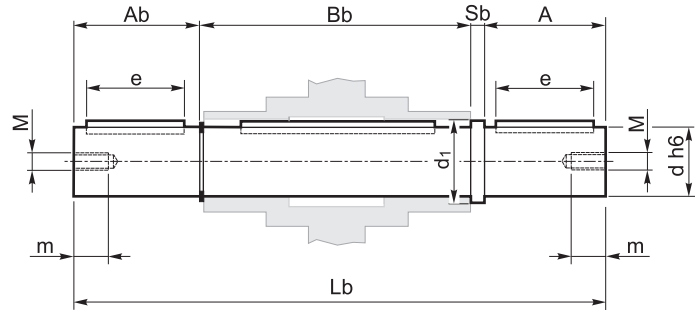
 Albero lento doppio  
 Double output shaft  
 Doppelte Abtriebswelle

A	A <sub>b</sub>	B <sub>b</sub>	d <sub>h6</sub>	d <sub>1</sub>	e	L <sub>b</sub>	S <sub>b</sub>
40	39	79	18	23.5	30	161	3
50	49	93	25	31.5	40	195.5	3.5
50	49	113	25	31.5	40	216	4
60	59	121	28	34.5	50	244	4
80	78.5	141.5	35	41.5	60	305	5
80	77.5	157	42	49.5	60	322.5	8
80	78	172	45	54.5	70	335	5

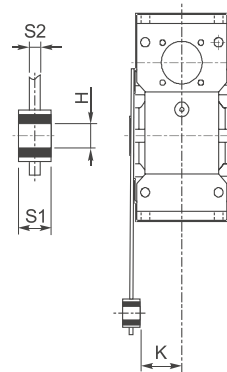
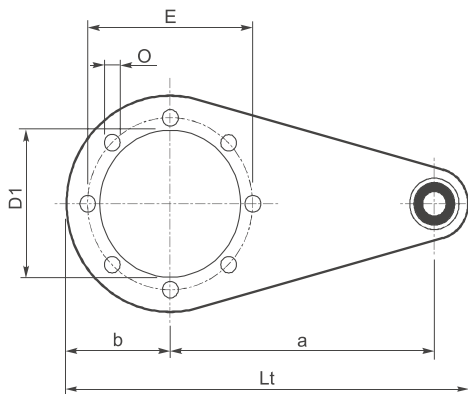
**Braccio di reazione**
**Torque arm**
**Drehmomentstütze**

H	a	b	D <sub>1</sub>	E	H	K	L <sub>t</sub>	O	S1	S2
40	100	45	60	75	10	31.5	167	7	14	4
50	100	50	70	85	10	39	172	9	14	5
63	150	55	80	95	10	49	227	9	14	6
75	200	70	95	115	20	47.5	302	9	25	6
90	200	80	110	130	20	57.5	312	11	25	6
110	250	100	130	165	25	62	390	11	30	6
130	250	125	180	215	25	69	415	13	30	6

**Kit di protezione**
**Protection Kit**
**Schutzvorrichtung**

Albero cavo / Hollow shaft / Hohlwelle

Limitatore di coppia / Torque limiter / Drehmomentbegrenzer

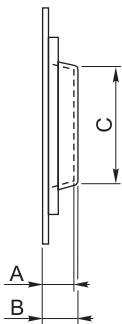

	A	B	C
40	14	15.5	44
50	15	16.5	54
63	17	19	60
75	18	20	70
90	21.5	24	80
110	22	25	96
130	22	25	130

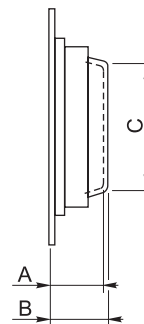

	A	B	C
40	40	41.5	44
50	47	48.5	53
63	52	54	55
75	58	60	68
90	60.5	63	70
110	72	75	85
130			

**Opzioni disponibili:**

Cuscinetti a rulli conici corona

**Available options:**

Tapered roller bearing on wormgear

**Auf Anfrage ist folgendes Zubehör erhältlich:**

Kegelrollenlager auf Schneckenrad



## Targhetta

## Plate

## Schild

In fase di ordine delle parti di ricambio, specificare sempre n° particolare (vedi disegno esploso), data (1), n° codice (2) e n° variante (3). (Vedi targhetta).

When ordering please specify the spare part number (see exploded view) as well as the date (1), the article number (2) and the variant number (3). (see plate)

Bei der Bestellung von Ersatzteilen sind Ersatzteilnummer (s. Explosionszeichnung), Datum (1), Artikelnummer (2) und Variantenummer (3) anzugeben. (s. Schild)

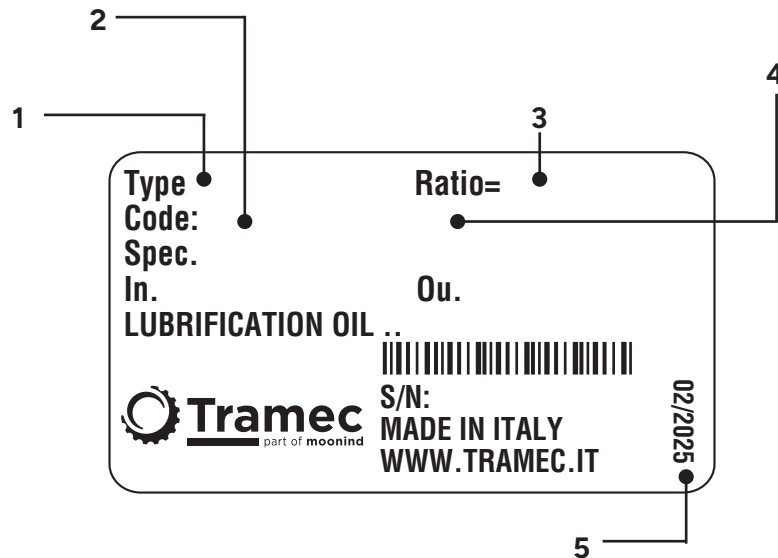

1	TIPO: descrizione	TYPE: description	TYP: Bezeichnung
2	CODICE: distinta base	CODE: base list	ART.-Nr.: Basisstückliste
3	RAP: rapporto di riduzione	RATIO: reduction ratio	ÜBERS: Untersetzungsverhältnis
4	VARIANTE: codice alfanumerico	MODEL: alphanumeric code	VARIANTE: alphanumerische Nummer
5	DATA: mese/anno	DATE: month/year	DATUM: Monat/Jahr

**RIDUTTORI A VITE  
 SENZA FINE  
 COMBINATI**
**COMBINED WORM  
 GEARBOXES**
**KOMBINIERTE-  
 SCHNECKENGETRIEBE**
**XX**
**KX**
**KK**

Caratteristiche	<i>Characteristics</i>	Merkmale	E2
Designazione	<i>Designation</i>	Bezeichnung	E2
Posizioni di montaggio	<i>Mounting position</i>	Einbaulage	E6
Posizione morsettiera	<i>Terminal board position</i>	Lage des Klemmbrett	E7
Lubrificazione	<i>Lubrication</i>	Schmierung	E8
Dati tecnici	<i>Technical data</i>	Technische Daten	E11
Dimensioni	<i>Dimensions</i>	Abmessungen	E16
Limitatore di coppia cavo passante	<i>Torque limiter with through hollow shaft</i>	Drehmomentbegrenzer mit durchgehender Hohlwelle	E22
Esecuzione con vite bisporgente	<i>Double extended worm shaft design</i>	Versionen mit Doppelseitig Herausragender Schneckenwelle	E24
Accessori	<i>Accessories</i>	Zubehör	E25
Lista parti di ricambio	<i>Spare parts list</i>	Ersatzteilliste	E27
Targhetta	<i>Plate</i>	Schild	E28

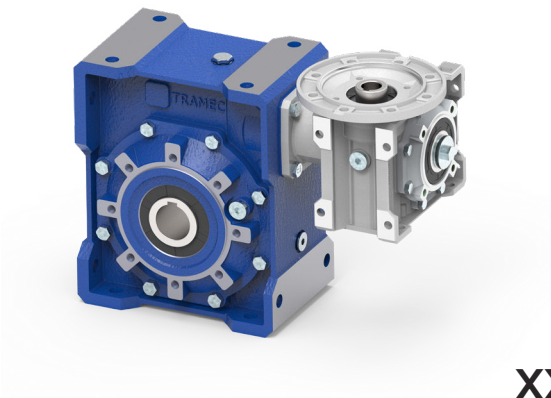
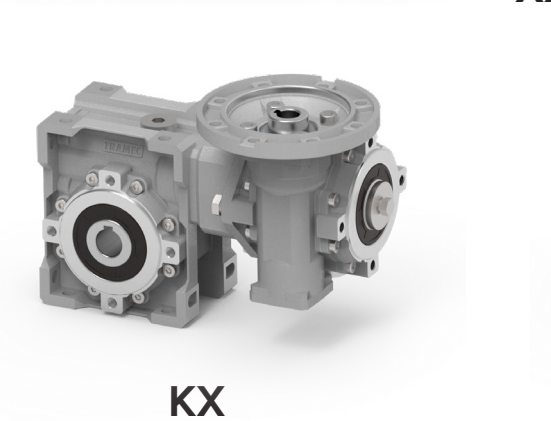
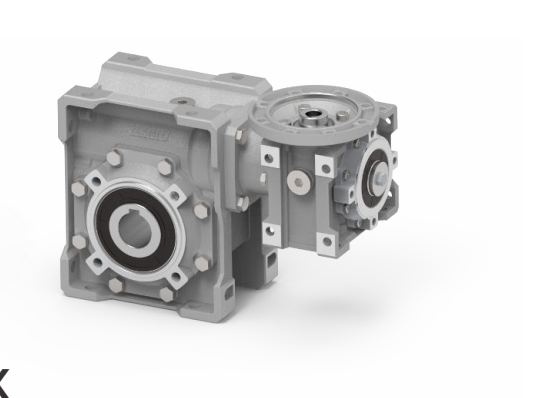
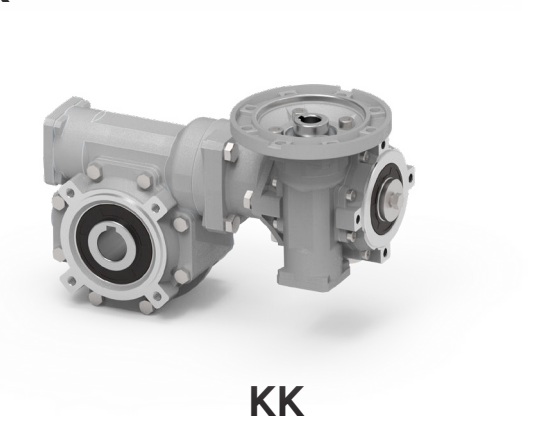
**XX**

**KX**

**KK**

## Caratteristiche

La combinazione di due riduttori a vite senza fine comporta rendimenti molto bassi, ma l'elevata riduzione di velocità ottenuta in uno spazio ridottissimo rende comunque interessante, e a volte insostituibile, questa soluzione. I riduttori a vite senza fine combinati sono disponibili nelle serie KX, XX e KK.

Le serie KX e KK sono disponibili esclusivamente nella versione p.a.m.

La serie XX è invece disponibile nella versione alberata XXA e nelle due versioni con predisposizione attacco motore in forma compatta XXC o con campana e giunto XXF.

Sono forniti con albero cavo di serie ed esiste un'ampia gamma di accessori: seconda entrata, cuscinetti conici sulla corona, flangia uscita, albero lento con 1 o 2 sporgenze, limitatore di coppia con cavo passante, braccio di reazione.

## Characteristics

The combination of two worm gearboxes provides very low efficiency, however the fact that substantial reduction in speed can be obtained in an extremely reduced space makes this solution very interesting and sometimes irreplaceable. Combined worm gearboxes are available in series: KX, XX and KK.

The KX and KK series are available for IEC version only.

The XX series is available in the XXA version with shaft and in two versions with motor coupling: XXC (compact) and XXF (with bell and joint).

The hollow shaft is supplied as standard. A broad range of accessories is available: second input, tapered roller bearings on the worm wheel, output flange, single or double extended output shaft, torque limiter with through hollow shaft, torque arm.

## Merkmale

Die Kombination zweier Schneckengetriebe bringt sehr niedrigen Wirkungsgrad mit sich, es handelt sich jedoch um eine interessante und manchmal unersetzbare Lösung, weil hohe Drehzahlverringering in einem beträchtlich reduzierten Raum erhalten werden kann. Kombinierte Schneckengetriebe sind in folgende Serien erhältlich: KX, XX und KK. Die Serien KX und KK sind nur mit IEC-Motoranbau verfügbar.

Die Serie XX ist mit Welle (XXA Version), oder mit Kupplung für Motoranschluss (XXC kompakt und XXF mit Glocke und Verbindsstück) lieferbar.

Die Hohlwelle gehört zur serienmäßigen Ausstattung. Eine breite Auswahl an Zubehör ist erhältlich: zweiter Antrieb, Kegelrollenlager auf Schneckenrad, Abtriebsflansch, Standard oder doppelseitig herausragende Abtriebswelle, Drehmomentbegrenzer mit durchgehender Hohlwelle, Drehmomentstütze.

## Designazione

## Designation

## Bezeichnung

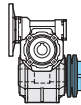
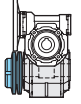
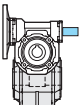
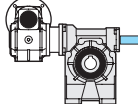
Riduttore entrata Gearbox at input Getriebe am Antrieb	Macchina uscita Gearbox at output Getriebe am Abtrieb	Tipo entrata Input type Antriebsart	Grandezza Size Größe	Versione Version Version	Rapporto rid. Ratio Untersetzung	Predispos.att. mot. Motor coupling Motoranschluss	Albero uscita cavo Hollow output shaft Abtriebshohlwelle	Flangia uscita Output flange Abtriebsflansch	Limitatore di coppia. Torque limiter Drehmomentbegrenzer	Seconda entrata Additional input Zusatzantrieb	Forma costruttiva Execution Bauform	Posizione di mont. Mounting position Einbaulage
<b>K</b>	<b>K</b>	<b>C</b>	<b>50/110</b>	<b>F1</b>	<b>1200</b>	<b>P.A.M.</b>	<b>H42</b>	<b>F1S</b>	<b>LD</b>	<b>SeA1</b>	<b>a</b>	<b>B3</b>
Riduttore a vite senza fine combinato Combined worm gearbox Doppelschneckengetriebe			 C	30/30 30/40 30/50 30/63 40/63 40/75 40/89 40/90 50/75 50/89 50/90 50/110 63/110 63/130	P F (1-2-3) A (1-2) B (1-2) V (1-2)	150 200 300 450 600 900 1200 1500 1950 2500 3250 4000 5000 10000	56 63 71 80 90	vedi tabelle see tables siehe Tabellen	 LD   LS	 SeA1   SeA2	ab cd ef gh ik im no pq	B3 B6 B7 B8 V5 V6

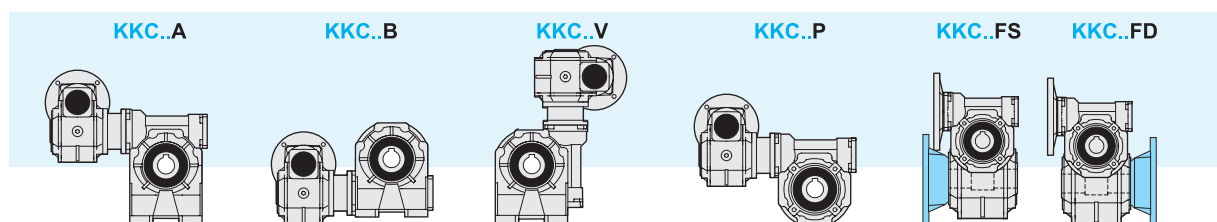

**Designazione**
**Designation**
**Bezeichnung**

Forma costruttiva / version / Bauform

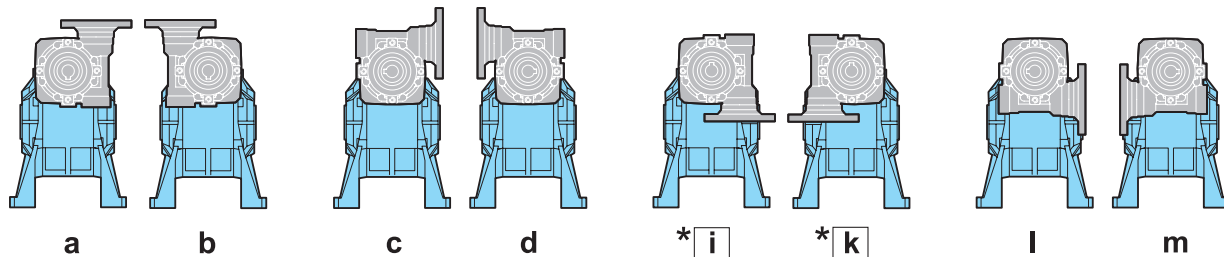
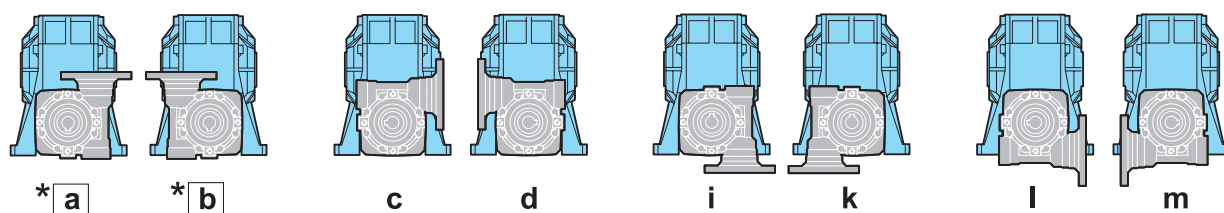
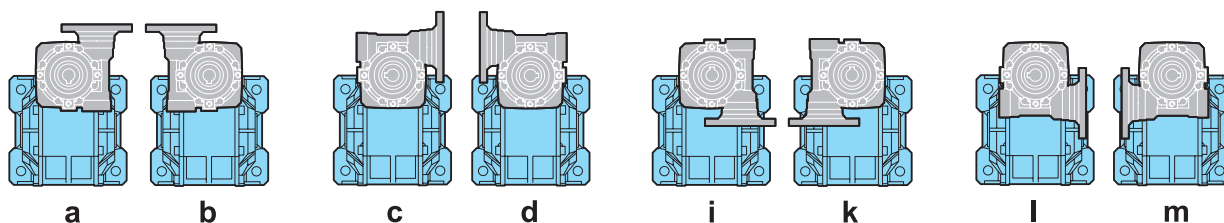
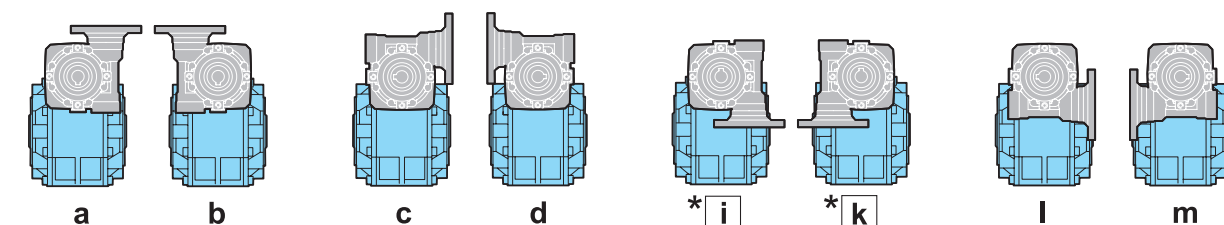
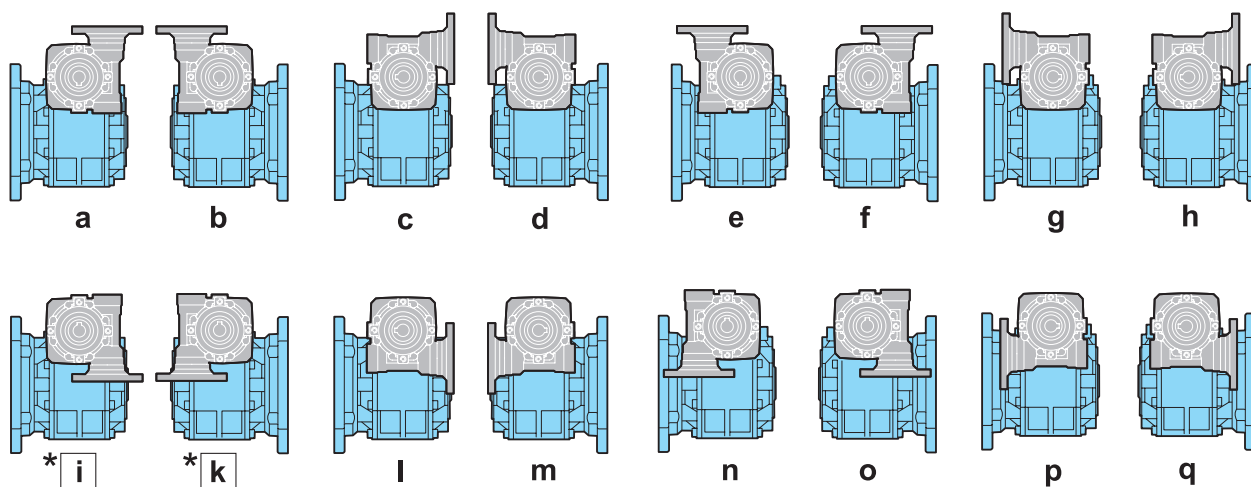

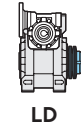
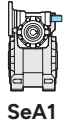

**A**

**B**

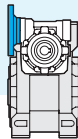
**V**

**P**

**F**

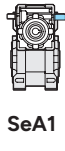
\*  Forma costruttiva non realizzabile su: / Version not feasible on: / Bauform nicht ausführbar für:  
 30/30, 30/40, 30/50 PAM 63B5 (ø 140), 40/63 PAM 71B5 (ø 160)

**Designazione**
**Designation**
**Bezeichnung**

Riduttore entrata Gearbox at input Getriebe am Antrieb	Macchina uscita Gearbox at output Getriebe am Abtrieb	Tipo entrata Input type Antriebsart	Grandezza Size Größe	Versione Version Version	Rapporto rid. Ratio Untersetzung	Predispos.att. mot. Motor coupling Motoranschluss	Albero uscita cavo Hollow output shaft Abtriebshohlwelle	Flangia uscita Output flange Abtriebsflansch	Limitatore di coppia. Torque limiter Drehmoment- begrenzer	Seconda entrata Additional input Zusatzantrieb	Forma costruttiva Execution Bauform	Posizione di mont. Mounting position Einbaulage
<b>K</b>	<b>X</b>	<b>C</b>	<b>50/110</b>	<b>F1</b>	<b>1200</b>	<b>P.A.M.</b>	<b>H42</b>	<b>F1S</b>	<b>LD</b>	<b>SeA1</b>	<b>a</b>	<b>B3</b>
Riduttore a vite senza fine combinato Combined worm gearbox Doppelschneckengetriebe		<b>C</b>	30/30	<b>P</b>  <b>F</b> (1-2-3)	150	<b>56</b>  <b>63</b>  <b>71</b>  <b>80</b>  <b>90</b>	vedi tabelle  see tables  siehe Tabellen	<b>F1S-F2S</b> <b>F3S</b> <b>F1D-F2D</b> <b>F3D</b>	  <b>LD</b>	  <b>SeA1</b>	<b>ab</b>  <b>cd</b>  <b>ef</b>  <b>gh</b>  <b>ik</b>  <b>im</b>  <b>no</b>  <b>pq</b>	<b>B3</b>  <b>B6</b>  <b>B7</b>  <b>B8</b>  <b>V5</b>  <b>V6</b>
			30/40		200							
			30/50		300							
			30/63		450							
			40/63		600							
			40/75		900							
			40/89		1200							
			40/90		1500							
			50/75		1950							
			50/89		2500							
			50/90		3250							
			50/110		4000							
			63/110		5000							
63/130	10000											

**KXC..**

Riduttore entrata Gearbox at input Getriebe am Antrieb	Macchina uscita Gearbox at output Getriebe am Abtrieb	Tipo entrata Input type Antriebsart	Grandezza Size Größe	Versione Version Version	Rapporto rid. Ratio Untersetzung	Predispos.att. mot. Motor coupling Motoranschluss	Albero uscita cavo Hollow output shaft Abtriebshohlwelle	Flangia uscita Output flange Abtriebsflansch	Limitatore di coppia. Torque limiter Drehmoment- begrenzer	Seconda entrata Additional input Zusatzantrieb	Forma costruttiva Execution Bauform	Posizione di mont. Mounting position Einbaulage
<b>X</b>	<b>X</b>	<b>C</b>	<b>50/110</b>	<b>F1</b>	<b>1200</b>	<b>P.A.M.</b>	<b>H42</b>	<b>F1S</b>	<b>LD</b>	<b>SeA1</b>	<b>a</b>	<b>B3</b>
Riduttore a vite senza fine combinato Combined worm gearbox Doppelschneckengetriebe	    	<b>A</b>  <b>C</b>  <b>F</b>	30/30	<b>P</b>  <b>F</b> (1-2-3)	150	<b>56</b>  <b>63</b>  <b>71</b>  <b>80</b>  <b>90</b>	vedi tabelle  see tables  siehe Tabellen	<b>F1S-F2S</b> <b>F3S</b> <b>F1D-F2D</b> <b>F3D</b>	  <b>LD</b>	  <b>SeA1</b>	<b>ab</b>  <b>cd</b>  <b>ef</b>  <b>gh</b>  <b>ik</b>  <b>im</b>  <b>no</b>  <b>pq</b>	<b>B3</b>  <b>B6</b>  <b>B7</b>  <b>B8</b>  <b>V5</b>  <b>V6</b>
			30/40		200							
			30/50		300							
			30/63		450							
			40/63		600							
			40/75		900							
			40/89		1200							
			40/90		1500							
			50/75		1950							
			50/89		2500							
			50/90		3250							
			50/110		4000							
			63/110		5000							
63/130	10000											

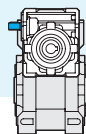
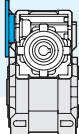
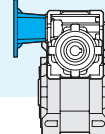
**XXA..**

**XXC..**

**XXF..**

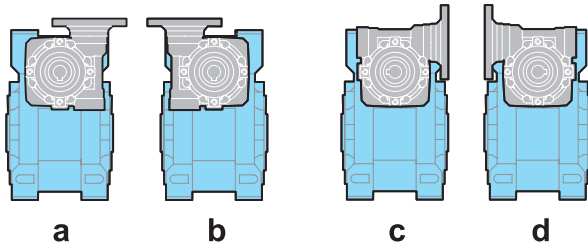
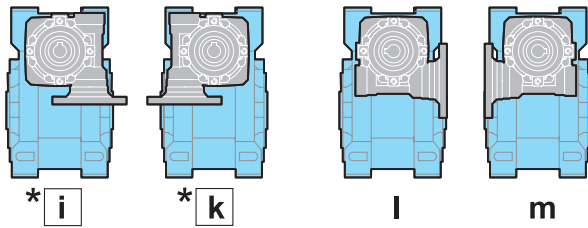
**Designazione**
**Designation**
**Bezeichnung**

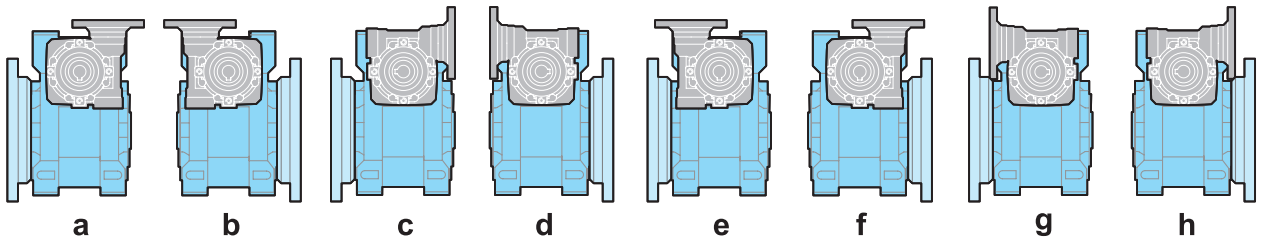
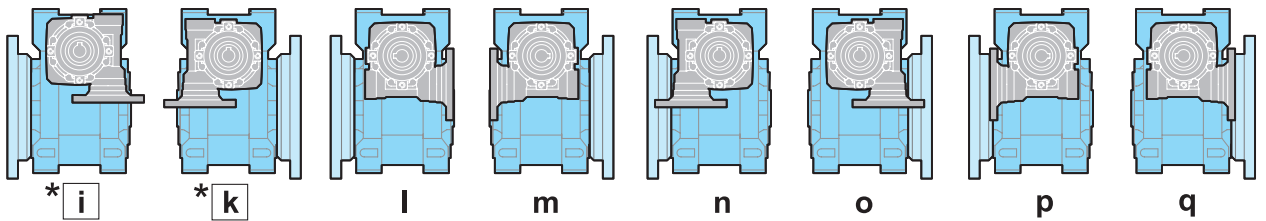
Forma costruttiva / version / Bauform

**P**

 Forma costruttiva non realizzabile su:  
 Version not feasible on:  
 Bauform nicht ausführbar für:

 30/30, 30/40, 30/50 PAM 63B5 (ø 140),  
 40/63 PAM 71B5 (ø 160)

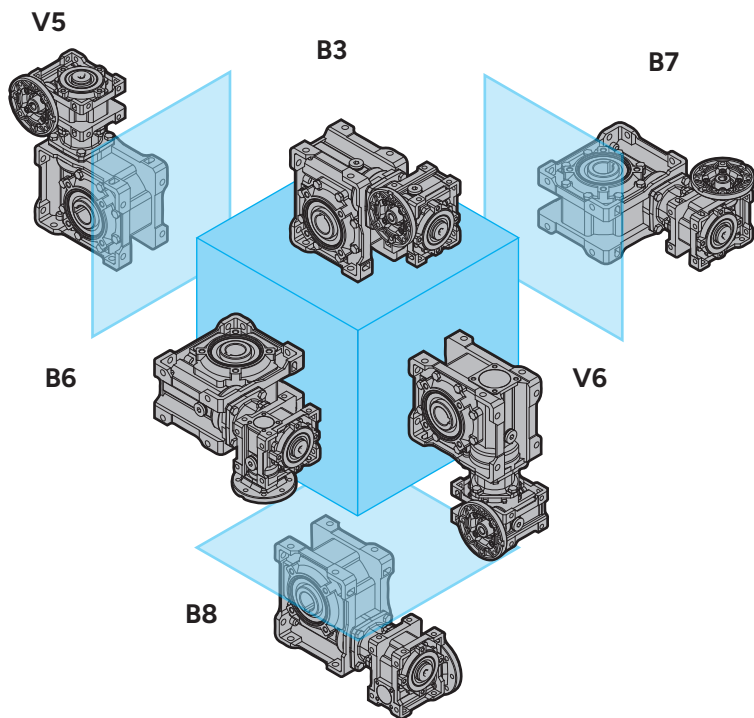
**F**

**XX**



Lo schema rappresentato è da considerarsi valido anche per le altre versioni costruttive.

*The diagram shown is also valid for other construction versions.*

Das dargestellte Diagramm ist auch für andere Bauvarianten gültig.

**KX**

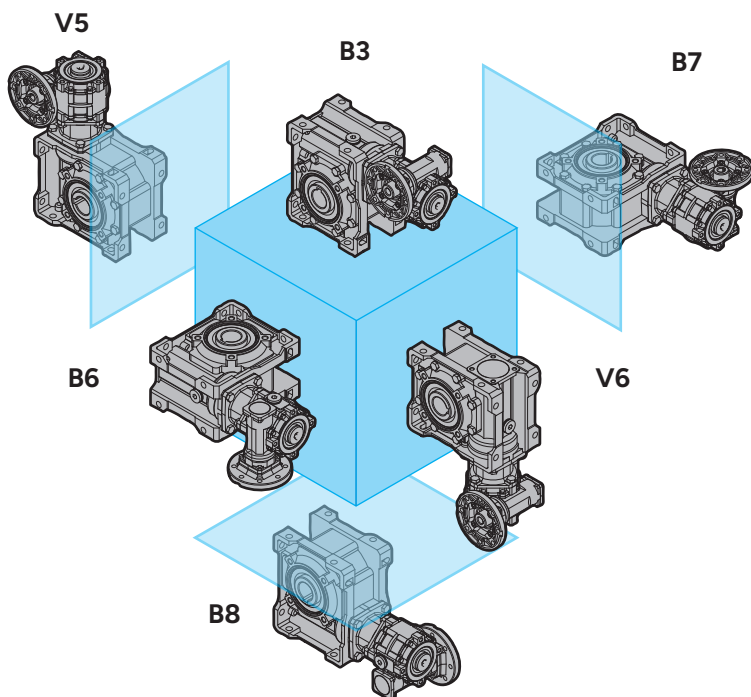

Lo schema rappresentato è da considerarsi valido anche per le altre versioni costruttive.

*The diagram shown is also valid for other construction versions.*

Das dargestellte Diagramm ist auch für andere Bauvarianten gültig.

**Posizioni di montaggio**

**Mounting positions**

**Montageposition**

**KK**

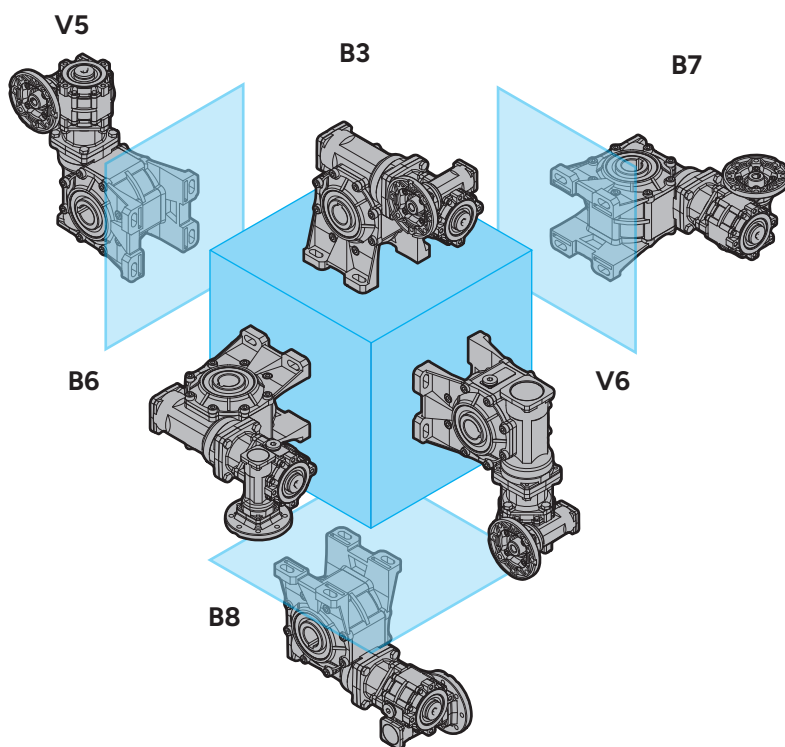

Lo schema rappresentato è da considerarsi valido anche per le altre versioni costruttive.

*The diagram shown is also valid for other construction versions.*

Das dargestellte Diagramm ist auch für andere Bauvarianten gültig.

**Posizione morsettiera**

**Terminal board position**

**Lage des Klemmenkastens**

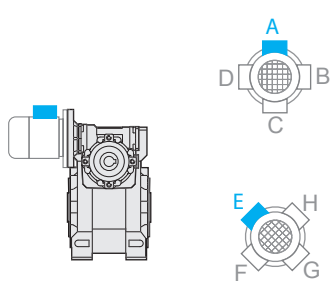
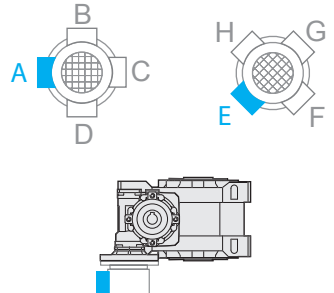
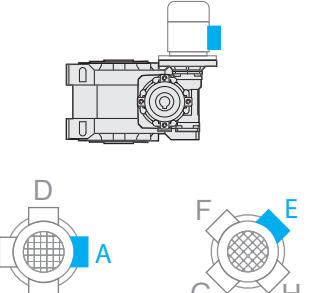
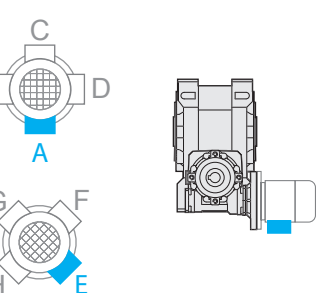
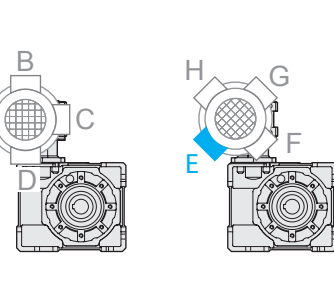
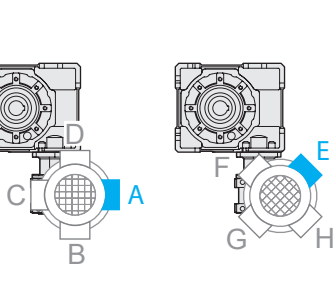
<p><b>B3</b></p> 	<p><b>B6</b></p> 	<p><b>B7</b></p> 
<p><b>B8</b></p> 	<p><b>V5</b></p> 	<p><b>V6</b></p> 

Specificare sempre in fase di ordinazione la posizione di montaggio e la forma costruttiva.  
Posizione morsettiera v. pag. E21-E22 (PM=1; PM=2)

*Mounting position always to be specified when ordering.  
Terminal board position see page E21-E22 (PM=1; PM=2)*

Bei der Bestellung immer die gewünschte Montageposition und Bauform angeben.  
Lage der Klemmenkaste Seite E21-E22 (PM=1; PM=2)

## Lubrificazione

I riduttori a vite senza fine combinati sono forniti completi di lubrificante sintetico a base PAG con indice di viscosità ISO VG320. Si raccomanda di precisare sempre in fase di ordine la forma costruttiva e la posizione di lavoro desiderata.

Per ulteriori dettagli consultare pag. A19 paragrafo "Lubrificazione".

## Lubrication

*Combined worm gearboxes are supplied with synthetic lubricant, PAG base, viscosity index ISO VG320. Required version and mounting position always to be specified when ordering.*

*For more details, see page A19, paragraph "Lubrication".*

## Schmierung

Kombinierte Schneckengetriebe werden mit synthetischem Schmiermittel auf PAG Basis und Viskosität Index ISO VG320 geliefert. Im Auftrag sind immer Einbaulage und Bauform anzugeben.

Weitere Einzelheiten finden Sie auf Seite A19, Absatz Schmierung.

### Lubrificazione

### Lubrication

### Schmierung

Posizione dei tappi e quantità di lubrificante (litri)

Positions of the plugs and lubricant quantity (liters)

Position der Kappen und Ölmenge (liter)

**F** (b, d, f, h, k, m, o, q)

**P** (a, b, c, d, i, k, l, m)

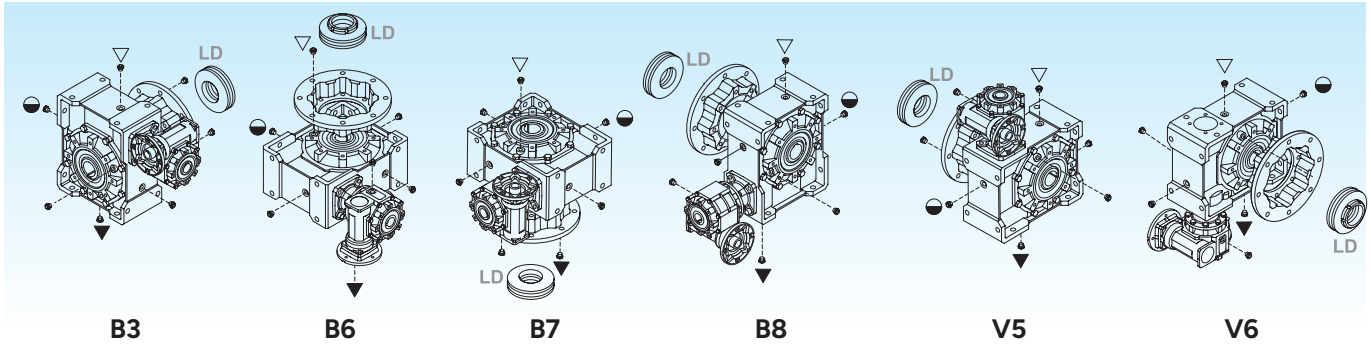

**F** (a, c, e, g, i, l, n, p)

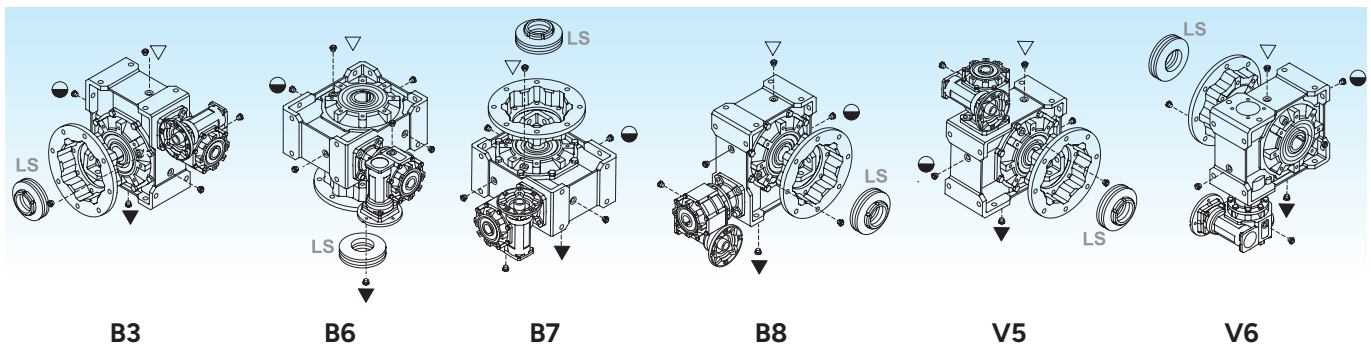

- ▽ Carico e sfiato / Filling and breather  
Einfüll und Entlüftung
- Livello / Level / Ölstand
- ▼ Scarico / Drain / Ablass

Nei corpi in alluminio 30, 40, 50, 63, 75 e 89 è presente un solo tappo di riempimento olio.

Aluminium housings size 30, 40, 50, 63, 75 and 89 have one filling plug only.

Gehäuse aus Aluminium Größe 30, 40, 50, 63, 75 und 89 verfügen über nur eine Einfüllschraube.

		Q.tà olio / Oil quantity / Schmiermittelmenge [lt]														
		XXA - XXC - KXC - XXF														
		30/30	30/40	30/50	30/63	40/63	40/75	40/89	40/90	50/75	50/89	50/90	50/110	63/110	63/130	
Posizioni di montaggio Mounting positions Einbaulage	B3	IN	0.015				0.04				0.08				0.16	0.4
		OUT	0.015	0.04	0.08	0.16	0.16	0.26	0.45	1.1	0.26	0.45	1.1	2.2	2.2	3.6
	B6	IN	0.015				0.04				0.08				0.16	0.4
		OUT	0.030	0.060	0.120	0.220	0.220	0.34	0.75	0.9	0.26	0.75	0.9	1.8	1.8	3.0
	B7	IN	0.015				0.04				0.08				0.16	0.4
		OUT	0.030	0.060	0.120	0.220	0.220	0.34	0.75	0.9	0.26	0.75	0.9	1.8	1.8	3.0
	B8	IN	0.015				0.04				0.08				0.16	0.4
		OUT	0.015	0.04	0.08	0.16	0.16	0.26	0.45	1	0.26	0.45	1	1.6	1.6	2.5
	V5	IN	0.030				0.06				0.12				0.22	0.22
		OUT	0.015	0.04	0.08	0.16	0.16	0.26	0.45	1.5	0.26	0.45	1.5	2.6	2.6	3.8
	V6	IN	0.030				0.06				0.12				0.22	0.22
		OUT	0.015	0.04	0.08	0.16	0.16	0.26	0.45	1.5	0.26	0.45	1.5	2.6	2.6	3.8

IN = Riduttore entrata / Gearbox at input / Getriebe am Antrieb

OUT = Riduttore uscita / Gearbox at output / Getriebe am Abtrieb

**Lubrificazione**

**Lubrication**

**Schmierung**

**F,P**

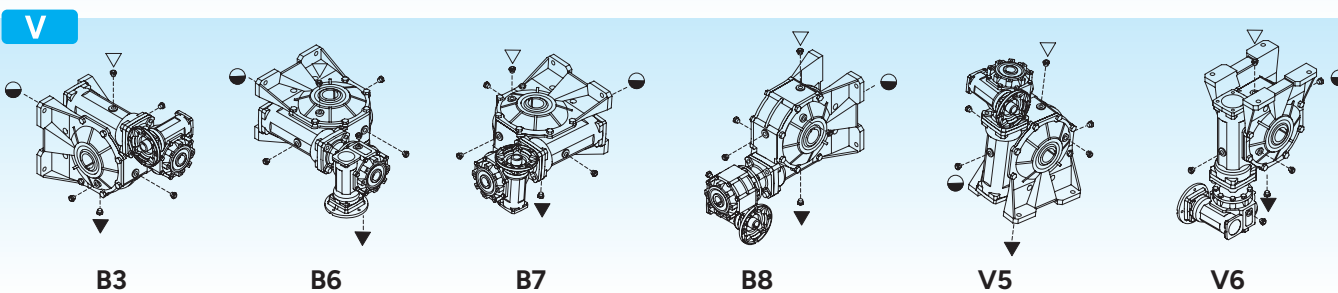
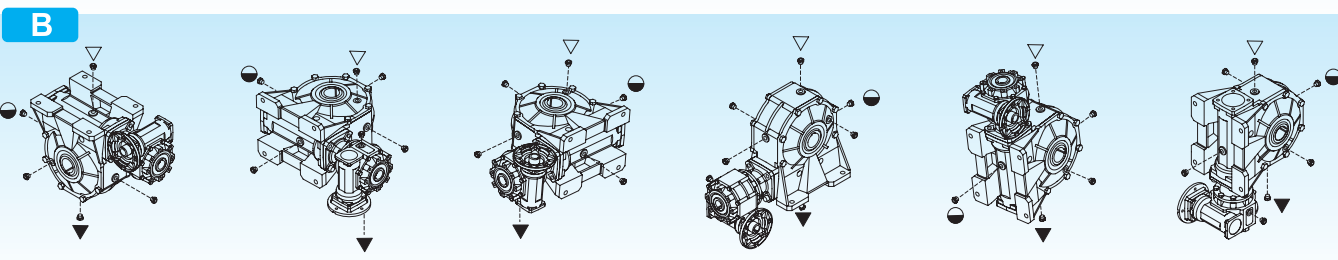
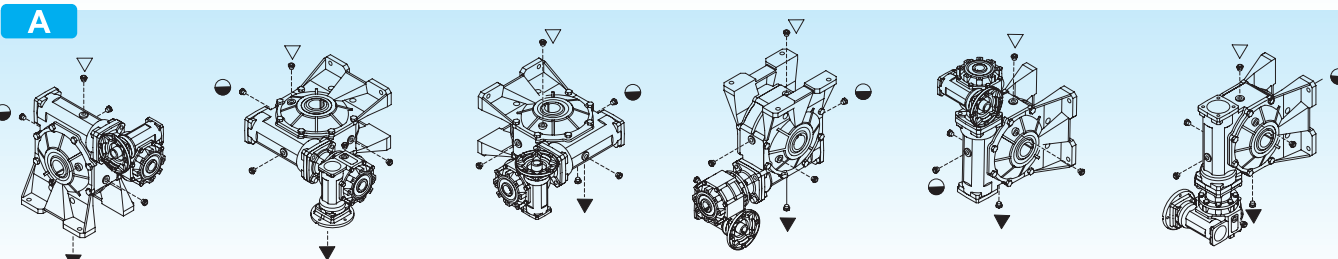
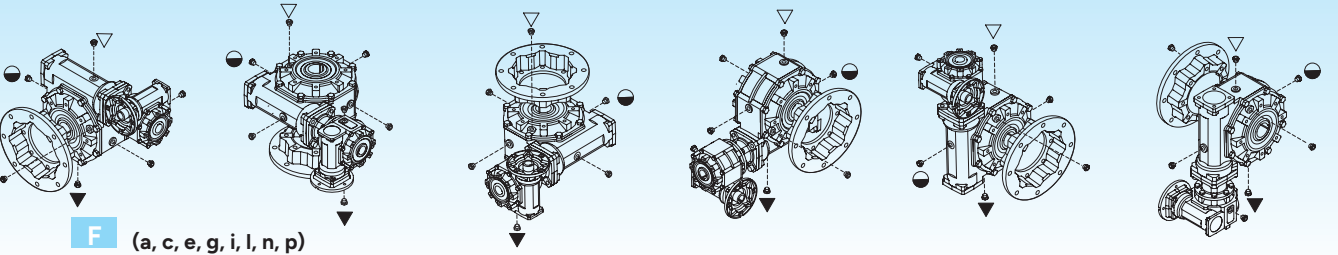
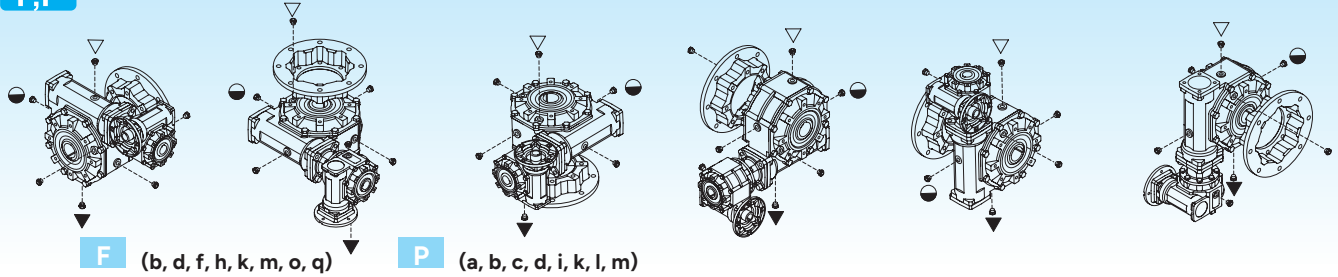

		Q.tà olio / Oil quantity / Schmiermittelmenge [lt]													
		Combinato tipo: <b>KKC</b>													
		30/30	30/40	30/50	30/63	40/63	40/75	40/89	40/90	50/75	50/89	50/90	50/110	63/110	63/130
Posizioni di montaggio Mounting positions Einbaulage	<b>B3</b>	IN	0.015			0.04				0.08			0.16	0.16	
		OUT	0.015	0.04	0.08	0.16	0.16	0.26	0.60	1	0.26	1	2	2	3
	<b>B6</b>	IN	0.015			0.04				0.08			0.16	0.4	
		OUT	0.030	0.060	0.120	0.220	0.220	0.340	0.70	0.9	0.26	0.9	1.8	1.8	3.0
	<b>B7</b>	IN	0.015			0.04				0.08			0.16	0.4	
		OUT	0.030	0.060	0.120	0.220	0.220	0.340	0.70	0.9	0.26	0.9	1.8	1.8	3.0
	<b>B8</b>	IN	0.015			0.04				0.08			0.16	0.16	
		OUT	0.015	0.04	0.08	0.16	0.16	0.26	0.60	0.8	0.26	0.8	2	2	2.1
	<b>V5</b>	IN	0.030			0.060				0.120			0.220	0.220	
		OUT	0.015	0.04	0.08	0.16	0.16	0.26	0.60	1.5	0.26	1.5	2.6	2.6	3.8
	<b>V6</b>	IN	0.030			0.060				0.120			0.220	0.220	
		OUT	0.015	0.04	0.08	0.16	0.16	0.26	0.60	1.5	0.26	1.5	2.6	2.6	3.8

**IN** = Riduttore entrata / Gearbox at input / Getriebe am Antrieb      **OUT** = Riduttore uscita / Gearbox at output / Getriebe am Abtrieb

Riduttore XX-KX-KK | XX-KX-KK Gearbox | Getriebe XX-KXXK-KK

**Dati tecnici**
**Technical data**
**Technische Daten**

	$n_1 = 1400$					XXA		KXC - XXC - XXF - KKC											
	in	30	30	$n_2$	Rd	$T_{2M}$	P	$T_2$	$P_1$	FS'	Input - IEC								
		$i_1$	$i_2$								KC - XC				XF				
											B5/B14		B5		B14				
<b>30/30</b>	150	10	15	9.3	0.51	37	0.070	32	0.06	1.2	—	63	56	—	63	56	—	63	56
	200		20	7.0	0.47	32	0.050	39	0.06	0.8									
	300				4.7	0.42	39	0.045	52*	0.06									
	450	15		3.1	0.40	39	0.032	73*	0.06	0.5*									
	600	20		2.3	0.37	39	0.026	91*	0.06	0.4*									
	900	30	30	1.6	0.34	39	0.019	125*	0.06	0.3*									
	1200	40		1.2	0.30	39	0.016	149*	0.06	0.3*									
	1500	50		0.9	0.28	39	0.014	173*	0.06	0.2*									
	1950	65		0.7	0.26	39	0.011	209*	0.06	0.2*									
	2500	50	50	0.6	0.23	30	0.008	235*	0.06	0.1*									
	3250	65		0.4	0.21	30	0.006	283*	0.06	0.11*									
	4000	80		0.4	0.20	30	0.005	328*	0.06	0.09*									
	5000	100		0.3	0.19	30	0.005	385*	0.06	0.08*									
10000	100	0.1		0.15	17	0.002	609*	0.06	0.03*										



3.0

	$n_1 = 1400$					XXA		KXC - XXC - XXF - KKC											
	in	30	40	$n_2$	Rd	$T_{2M}$	P	$T_2$	$P_1$	FS'	Input - IEC								
		$i_1$	$i_2$								KC - XC				XF				
											B5/B14		B5		B14				
<b>30/40</b>	150	10	15	9.3	0.54	82	0.148	72	0.13	1.1	—	63	56	—	63	56	—	63	56
	200		20	7.0	0.51	76	0.110	76	0.11	1.0									
	300				4.7	0.43	82	0.094	79	0.09									
	450	15		3.1	0.40	82	0.067	74	0.06	1.1									
	600	20		2.3	0.37	82	0.054	92	0.06	0.9									
	900	30	30	1.6	0.34	82	0.039	126*	0.06	0.6*									
	1200	40		1.2	0.31	82	0.033	151*	0.06	0.5*									
	1500	50		0.9	0.29	82	0.028	176*	0.06	0.5*									
	1950	65		0.7	0.27	82	0.023	212*	0.06	0.4*									
	2500	50	50	0.6	0.23	68	0.017	236*	0.06	0.3*									
	3250	65		0.4	0.21	68	0.014	285*	0.06	0.24*									
	4000	80		0.4	0.20	68	0.012	330*	0.06	0.21*									
	5000	100		0.3	0.19	68	0.011	387*	0.06	0.18*									
10000	100	0.1		0.15	35	0.003	626*	0.06	0.06*										



4.0

	$n_1 = 1400$					XXA		KXC - XXC - XXF - KKC											
	in	30	50	$n_2$	Rd	$T_{2M}$	P	$T_2$	$P_1$	FS'	Input - IEC								
		$i_1$	$i_2$								KC - XC				XF				
											B5/B14		B5		B14				
<b>30/50</b>	150	10	15	9.3	0.55	149	0.265	124	0.22	1.2	—	63	56	—	63	56	—	63	56
	200		20	7.0	0.52	144	0.201	129	0.18	1.1									
	300				4.7	0.44	150	0.166	118	0.13									
	450	15		3.1	0.42	150	0.118	140	0.11	1.1									
	600	20		2.3	0.39	150	0.094	143	0.09	1.0									
	900	30	30	1.6	0.36	150	0.069	131	0.06	1.1									
	1200	40		1.2	0.32	150	0.058	156	0.06	1.0									
	1500	50		0.9	0.30	150	0.049	182	0.06	0.8									
	1950	65		0.7	0.28	150	0.041	220*	0.06	0.7*									
	2500	50	50	0.6	0.25	125	0.030	253*	0.06	0.5*									
	3250	65		0.4	0.23	125	0.025	305*	0.06	0.41*									
	4000	80		0.4	0.22	125	0.021	354*	0.06	0.35*									
	5000	100		0.3	0.20	125	0.018	414*	0.06	0.30*									
10000	100	0.1		0.16	69	0.006	645*	0.06	0.11*										



6.0

\* **ATTENZIONE:** la coppia massima utilizzabile  $[T_{2M}]$  deve essere calcolata utilizzando il fattore di servizio:  
 $T_{2M} = T_2 \times FS'$

\* **WARNING:** Maximum allowable torque  $[T_{2M}]$  must be calculated using the following service factor:  
 $T_{2M} = T_2 \times FS'$

\* **ACHTUNG:** das max. anwendbare Drehmoment  $[T_{2M}]$  muss mit folgendem Betriebsfaktor berechnet werden:  
 $T_{2M} = T_2 \times FS'$

Dati tecnici

Technical data

Technische Daten

30/63	n <sub>1</sub> = 1400					XXA		KXC - XXC - XXF - KKC											
	in	30	63	n <sub>2</sub> [rpm]	Rd	T <sub>2M</sub> [Nm]	P [kW]	T <sub>2</sub> [Nm]	P <sub>1</sub> [kW]	FS'	Input - IEC								
		i <sub>1</sub>	i <sub>2</sub>								KC - XC				XF				
									B5/B14		B5		B14						
	150	10	15	9.3	0.56	228	0.400	126	0.22	1.8	—	63	56	—	63	56	—	63	56
	200		20	7.0	0.54	279	0.378	162	0.22	1.7									
	300	15	30	4.7	0.46	268	0.285	207	0.22	1.3									
	450			3.1	0.43	268	0.202	238	0.18	1.1									
	600	20	2.3	0.40	268	0.162	215	0.13	1.2										
	900	30	1.6	0.37	268	0.118	250	0.11	1.1										
	1200	40	1.2	0.33	268	0.099	243	0.09	1.1										
	1500	50	0.9	0.31	268	0.085	189	0.06	1.4										
	1950	65	0.7	0.29	268	0.071	228	0.06	1.2										
	2500	50	0.6	0.26	222	0.050	265	0.06	0.8										
	3250	65	0.4	0.24	222	0.042	319*	0.06	0.70*										
	4000	80	0.4	0.23	222	0.036	369*	0.06	0.60*										
	5000	100	0.3	0.21	222	0.031	433*	0.06	0.51*										
	10000	100	0.1	0.16	138	0.012	663*	0.06	0.21*										



8.5

40/63	n <sub>1</sub> = 1400					XXA		KXC - XXC - XXF - KKC											
	in	40	63	n <sub>2</sub> [rpm]	Rd	T <sub>2M</sub> [Nm]	P [kW]	T <sub>2</sub> [Nm]	P <sub>1</sub> [kW]	FS'	Input - IEC								
		i <sub>1</sub>	i <sub>2</sub>								KC - XC				XF				
									B5/B14		B5		B14						
	150	10	15	9.3	0.56	261	0.452	214	0.37	1.2	71	63	—	71	63	56	71	63	—
	200		20	7.0	0.55	279	0.373	277	0.37	1.0									
	300	15	30	4.7	0.46	268	0.282	238	0.25	1.1									
	450			3.1	0.44	268	0.197	244	0.18	1.1									
	600	20	2.3	0.43	268	0.154	226	0.13	1.2										
	900	30	1.6	0.38	268	0.115	257	0.11	1.0										
	1200	40	1.2	0.36	268	0.091	264	0.09	1.0										
	1500	50	0.9	0.33	268	0.079	203	0.06	1.3										
	1950	65	0.7	0.30	268	0.067	241	0.06	1.1										
	2500	50	0.6	0.28	222	0.047	284	0.06	0.8										
	3250	65	0.4	0.25	222	0.039	338*	0.06	0.66*										
	4000	80	0.4	0.24	222	0.033	400*	0.06	0.55*										
	5000	100	0.3	0.23	222	0.028	471*	0.06	0.47*										
	10000	100	0.1	0.18	138	0.011	722*	0.06	0.19*										



9.5

40/75	n <sub>1</sub> = 1400					XXA		KXC - XXC - XXF - KKC											
	in	40	75	n <sub>2</sub> [rpm]	Rd	T <sub>2M</sub> [Nm]	P [kW]	T <sub>2</sub> [Nm]	P <sub>1</sub> [kW]	FS'	Input - IEC								
		i <sub>1</sub>	i <sub>2</sub>								KC - XC				XF				
									B5/B14		B5		B14						
	150	10	15	9.3	0.57	409	0.698	322	0.55	1.3	71	63	—	71	63	56	71	63	—
	200		20	7.0	0.56	442	0.583	417	0.55	1.1									
	300	15	30	4.7	0.47	418	0.432	358	0.37	1.2									
	450			3.1	0.45	418	0.302	346	0.25	1.2									
	600	20	2.3	0.43	418	0.236	390	0.22	1.1										
	900	30	1.6	0.39	418	0.176	309	0.13	1.4										
	1200	40	1.2	0.36	418	0.140	388	0.13	1.1										
	1500	50	0.9	0.34	418	0.121	379	0.11	1.1										
	1950	65	0.7	0.31	418	0.102	368	0.09	1.1										
	2500	50	0.6	0.29	381	0.077	296	0.06	1.3										
	3250	65	0.4	0.26	381	0.065	352	0.06	1.08										
	4000	80	0.4	0.25	381	0.055	417	0.06	0.91										
	5000	100	0.3	0.24	381	0.047	491*	0.06	0.78*										
	10000	100	0.1	0.19	232	0.018	762*	0.06	0.30*										



14.5

\* **ATTENZIONE:** la coppia massima utilizzabile [T<sub>2M</sub>] deve essere calcolata utilizzando il fattore di servizio:  
T<sub>2M</sub> = T<sub>2</sub> x FS'

\* **WARNING:** Maximum allowable torque [T<sub>2M</sub>] must be calculated using the following service factor:  
T<sub>2M</sub> = T<sub>2</sub> x FS'

\* **ACHTUNG:** das max. anwendbare Drehmoment [T<sub>2M</sub>] muss mit folgendem Betriebsfaktor berechnet werden:  
T<sub>2M</sub> = T<sub>2</sub> x FS'

Dati tecnici

Technical data

Technische Daten

50/75	n <sub>1</sub> = 1400					XXA		KXC - XXC - XXF - KKC										
	in	50	75	n <sub>2</sub>	Rd	T <sub>2M</sub>	P	T <sub>2</sub>	P <sub>1</sub>	FS'	Input - IEC							
		i <sub>1</sub>	i <sub>2</sub>								KC - XC				XF			
	B5/B14		B5		B14													
150	10	15	9.3	0.57	409	0.750	409	0.75	1.0	80	71	63	80	71	63	80	71	—
200		20	7.0	0.56	442	0.576	422	0.55	1.0									
300	15	30	4.7	0.48	418	0.427	363	0.37	1.2	—	63	80	71	63	80	71	—	
450			3.1	0.46	418	0.299	350	0.25	1.2									
600	20	30	2.3	0.42	418	0.250	418	0.25	1.0	—	63	80	71	63	80	71	—	
900			1.6	0.40	418	0.180	418	0.18	1.0									
1200	40	50	1.2	0.38	418	0.134	406	0.13	1.0	—	63	80	71	63	80	71	—	
1500			0.9	0.35	418	0.116	470	0.13	0.9									
1950	65	50	0.7	0.33	418	0.095	572*	0.13	0.7*	—	63	80	71	63	80	71	—	
2500			0.6	0.30	381	0.074	674*	0.13	0.6*									
3250	80	100	0.4	0.28	381	0.060	819*	0.13	0.47*	—	63	80	71	63	80	71	—	
4000			0.4	0.26	381	0.053	939*	0.13	0.41*									
5000	100	100	0.3	0.25	381	0.045	1108*	0.13	0.34*	—	63	80	71	63	80	71	—	
10000			0.1	0.19	232	0.018	1719*	0.13	0.13*									

16.5

40/89	n <sub>1</sub> = 1400					XXA		KXC - XXC - XXF - KKC										
	in	40	90	n <sub>2</sub>	Rd	T <sub>2M</sub>	P	T <sub>2</sub>	P <sub>1</sub>	FS'	Input - IEC							
		i <sub>1</sub>	i <sub>2</sub>								KC - XC				XF			
	B5/B14		B5		B14													
150	10	15	9.3	0.58	392	0.659	327	0.55	1.2	71	63	56	71	63	56	71	63	—
200		20	7.0	0.56	504	0.654	424	0.55	1.2									
300	15	30	4.7	0.48	606	0.615	542	0.55	1.1	—	56	71	63	56	71	63	—	
450			3.1	0.46	606	0.430	520	0.37	1.2									
600	20	30	2.3	0.44	606	0.336	457	0.25	1.3	—	56	71	63	56	71	63	—	
900			1.6	0.39	606	0.250	605	0.25	1.0									
1200	40	50	1.2	0.37	606	0.199	668	0.22	0.9	—	56	71	63	56	71	63	—	
1500			0.9	0.34	594	0.169	630	0.18	0.9									
1950	65	50	0.7	0.31	558	0.134	542	0.13	1.0	—	56	71	63	56	71	63	—	
2500			0.6	0.30	571	0.112	564	0.11	1.0									
3250	80	100	0.4	0.28	571	0.094	549	0.09	1.0	—	56	71	63	56	71	63	—	
4000			0.4	0.27	571	0.079	651	0.09	0.88									
5000	100	100	0.3	0.25	571	0.067	767*	0.09	0.74*	—	56	71	63	56	71	63	—	
10000			0.1	0.19	361	0.028	1173*	0.09	0.31*									

15.4

40/90	n <sub>1</sub> = 1400					XXA		KXC - XXC - XXF - KKC										
	in	40	90	n <sub>2</sub>	Rd	T <sub>2M</sub>	P	T <sub>2</sub>	P <sub>1</sub>	FS'	Input - IEC							
		i <sub>1</sub>	i <sub>2</sub>								KC - XC				XF			
	B5/B14		B5		B14													
150	10	15	9.3	0.58	435	0.732	327	0.55	1.3	71	63	56	71	63	56	71	63	—
200		20	7.0	0.56	560	0.727	424	0.55	1.3									
300	15	30	4.7	0.48	673	0.683	542	0.55	1.2	—	56	71	63	56	71	63	—	
450			3.1	0.46	673	0.478	520	0.37	1.3									
600	20	30	2.3	0.44	673	0.373	668	0.37	1.0	—	56	71	63	56	71	63	—	
900			1.6	0.39	673	0.278	605	0.25	1.1									
1200	40	50	1.2	0.37	673	0.221	668	0.22	1.0	—	56	71	63	56	71	63	—	
1500			0.9	0.34	660	0.188	630	0.18	1.0									
1950	65	50	0.7	0.31	620	0.149	542	0.13	1.1	—	56	71	63	56	71	63	—	
2500			0.6	0.30	634	0.124	564	0.11	1.1									
3250	80	100	0.4	0.28	634	0.104	549	0.09	1.2	—	56	71	63	56	71	63	—	
4000			0.4	0.27	634	0.088	651	0.09	0.97									
5000	100	100	0.3	0.25	634	0.074	767	0.09	0.83	—	56	71	63	56	71	63	—	
10000			0.1	0.19	401	0.031	1173*	0.09	0.34*									

27

\* **ATTENZIONE:** la coppia massima utilizzabile [T<sub>2M</sub>] deve essere calcolata utilizzando il fattore di servizio:  
T<sub>2M</sub> = T<sub>2</sub> x FS'

\* **WARNING:** Maximum allowable torque [T<sub>2M</sub>] must be calculated using the following service factor:  
T<sub>2M</sub> = T<sub>2</sub> x FS'

\* **ACHTUNG:** das max. anwendbare Drehmoment [T<sub>2M</sub>] muss mit folgendem Betriebsfaktor berechnet werden:  
T<sub>2M</sub> = T<sub>2</sub> x FS'

**Dati tecnici**
**Technical data**
**Technische Daten**

50/89	$n_1 = 1400$					XXA		KXC - XXC - XXF - KKC											
	in	50	90	$n_2$	Rd	$T_{2M}$	P	$T_2$	$P_1$	FS'	Input - IEC								
		$i_1$	$i_2$								KC - XC		XF						
											B5/B14	B5		B14					
	150	10	15	9.3	0.59	<b>590</b>	0.980	541	0.90	1.1	80	71	—	80	71	63	80	71	—
	200		20	7.0	0.57	<b>638</b>	0.819	584	0.75	1.1									
	300	15	20	4.7	0.49	<b>606</b>	0.608	548	0.55	1.1	80	71	—	80	71	63	80	71	—
	450			3.1	0.46	<b>606</b>	0.426	527	0.37	1.1									
	600	30	20	2.3	0.45	<b>606</b>	0.327	463	0.25	1.3	80	71	—	80	71	63	80	71	—
	900			1.6	0.41	<b>606</b>	0.239	632	0.25	1.0									
	1200	40	30	1.2	0.39	<b>606</b>	0.191	573	0.18	1.1	80	71	—	80	71	63	80	71	—
	1500			0.9	0.36	<b>606</b>	0.165	662	0.18	0.9									
	1950	50	30	0.7	0.34	<b>606</b>	0.135	582	0.13	1.0	80	71	—	80	71	63	80	71	—
	2500			0.6	0.32	<b>571</b>	0.106	701	0.13	0.8									
	3250	65	50	0.4	0.30	<b>571</b>	0.087	853*	0.13	0.67*	80	71	—	80	71	63	80	71	—
	4000			0.4	0.28	<b>571</b>	0.076	977*	0.13	0.58*									
	5000	80	50	0.3	0.26	<b>571</b>	0.064	1153*	0.13	0.49*	80	71	—	80	71	63	80	71	—
	10000			0.1	0.20	<b>361</b>	0.027	1764*	0.13	0.20*									



17

50/90	$n_1 = 1400$					XXA		KXC - XXC - XXF - KKC											
	in	50	90	$n_2$	Rd	$T_{2M}$	P	$T_2$	$P_1$	FS'	Input - IEC								
		$i_1$	$i_2$								KC - XC		XF						
											B5/B14	B5		B14					
	150	10	15	9.3	0.59	<b>655</b>	1.089	541	0.90	1.2	80	71	—	80	71	63	80	71	—
	200		20	7.0	0.57	<b>709</b>	0.910	584	0.75	1.2									
	300	15	20	4.7	0.49	<b>673</b>	0.675	548	0.55	1.2	80	71	—	80	71	63	80	71	—
	450			3.1	0.46	<b>673</b>	0.473	527	0.37	1.3									
	600	30	20	2.3	0.45	<b>673</b>	0.363	463	0.25	1.5	80	71	—	80	71	63	80	71	—
	900			1.6	0.41	<b>673</b>	0.266	632	0.25	1.1									
	1200	40	30	1.2	0.39	<b>673</b>	0.212	573	0.18	1.2	80	71	—	80	71	63	80	71	—
	1500			0.9	0.36	<b>673</b>	0.183	662	0.18	1.0									
	1950	50	30	0.7	0.34	<b>673</b>	0.150	582	0.13	1.2	80	71	—	80	71	63	80	71	—
	2500			0.6	0.32	<b>634</b>	0.118	701	0.13	0.9									
	3250	65	50	0.4	0.30	<b>634</b>	0.097	853*	0.13	0.74*	80	71	—	80	71	63	80	71	—
	4000			0.4	0.28	<b>634</b>	0.084	977*	0.13	0.65*									
	5000	80	50	0.3	0.26	<b>634</b>	0.071	1153*	0.13	0.55*	80	71	—	80	71	63	80	71	—
	10000			0.1	0.20	<b>401</b>	0.030	1764*	0.13	0.23*									



29

\* **ATTENZIONE:** la coppia massima utilizzabile [ $T_{2M}$ ] deve essere calcolata utilizzando il fattore di servizio:  
 $T_{2M} = T_2 \times FS'$

\* **WARNING:** Maximum allowable torque [ $T_{2M}$ ] must be calculated using the following service factor:  
 $T_{2M} = T_2 \times FS'$

\* **ACHTUNG:** das max. anwendbare Drehmoment [ $T_{2M}$ ] muss mit folgendem Betriebsfaktor berechnet werden:  
 $T_{2M} = T_2 \times FS'$

**Dati tecnici**
**Technical data**
**Technische Daten**

50/110	$n_1 = 1400$					XXA		KXC - XXC - XXF - KKC										
	in	50	110	$n_2$	Rd	$T_{2M}$	P	$T_2$	$P_1$	FS'	Input - IEC							
		$i_1$	$i_2$								KC - XC		XF					
											B5/B14	B5		B14				
	150	10	15	9.3	0.60	785	1.269	557	0.9	1.4	80	—	80	71	63	80	71	—
	200		20	7.0	0.58	1000	1.265	712	0.9	1.4								
	300	15	30	4.7	0.50	1165	1.130	928	0.9	1.3	—	63	80	71	63	80	71	—
	450			3.1	0.48	1165	0.791	1105	0.75	1.1								
	600	20	30	2.3	0.47	1165	0.608	1054	0.55	1.1	—	63	80	71	63	80	71	—
	900			1.6	0.43	1165	0.445	968	0.37	1.2								
	1200	30	30	1.2	0.40	1165	0.354	823	0.25	1.4	—	63	80	71	63	80	71	—
	1500			0.9	0.37	1165	0.306	952	0.25	1.2								
	1950	50	50	0.7	0.35	1150	0.248	1018	0.22	1.1	—	63	80	71	63	80	71	—
	2500			0.6	0.33	1119	0.200	1009	0.18	1.1								
	3250	65	50	0.4	0.31	1119	0.164	886	0.13	1.26	—	63	80	71	63	80	71	—
	4000			0.4	0.29	1119	0.143	1015	0.13	1.10								
	5000	80	50	0.3	0.27	1119	0.121	1198	0.13	0.93	—	63	80	71	63	80	71	—
	10000			0.1	0.21	727	0.051	1854*	0.13	0.39*								



49

63/110	$n_1 = 1400$					XXA		KXC - XXC - XXF - KKC										
	in	63	110	$n_2$	Rd	$T_{2M}$	P	$T_2$	$P_1$	FS'	Input - IEC							
		$i_1$	$i_2$								KC - XC		XF					
											B5/B14	B5		B14				
	150	10	15	9.3	0.61	1123	1.793	939	1.5	1.2	90	—	80	80	71	90	80	—
	200		20	7.0	0.59	1229	1.536	1200	1.5	1.0								
	300	15	30	4.7	0.51	1165	1.116	1148	1.1	1.0	—	71	90	80	71	90	80	—
	450			3.1	0.49	1165	0.781	1119	0.75	1.0								
	600	20	30	2.3	0.48	1165	0.593	1081	0.55	1.1	—	71	90	80	71	90	80	—
	900			1.6	0.44	1165	0.433	995	0.37	1.2								
	1200	30	30	1.2	0.40	1165	0.370	1165	0.37	1.0	—	71	90	80	71	90	80	—
	1500			0.9	0.39	1165	0.292	998	0.25	1.2								
	1950	50	50	0.7	0.37	1165	0.239	1217	0.25	1.0	—	71	90	80	71	90	80	—
	2500			0.6	0.34	1119	0.190	1469	0.25	0.8								
	3250	65	50	0.4	0.32	1119	0.156	1792*	0.25	0.62*	—	71	90	80	71	90	80	—
	4000			0.4	0.31	1119	0.133	2097*	0.25	0.53*								
	5000	80	50	0.3	0.28	1119	0.117	2395*	0.25	0.47*	—	71	90	80	71	90	80	—
	10000			0.1	0.22	727	0.049	3706*	0.25	0.20*								



52

63/130	$n_1 = 1400$					XXA		KXC - XXC - XXF - KKC										
	in	63	130	$n_2$	Rd	$T_{2M}$	P	$T_2$	$P_1$	FS'	Input - IEC							
		$i_1$	$i_2$								KC - XC		XF					
											B5/B14	B5		B14				
	150	10	15	9.3	0.64	1438	2.2	1176	1.8	1.2	90	—	80	80	71	90	80	—
	200		20	7	0.61	1831	2.2	1498	1.8	1.2								
	300	15	30	4.7	0.53	1890	1.7	1627	1.5	1.2	—	71	90	80	71	90	80	—
	450			3.1	0.49	1890	1.3	1655	1.1	1.1								
	600	20	30	2.3	0.47	1890	0.98	1731	0.9	1.1	—	71	90	80	71	90	80	—
	900			1.6	0.42	1890	0.73	1934	0.75	1								
	1200	30	30	1.2	0.39	1890	0.59	1756	0.55	1.1	—	71	90	80	71	90	80	—
	1500			0.9	0.36	1890	0.51	2026	0.55	0.9								
	1950	50	50	0.7	0.34	1890	0.42	1673	0.37	1.1	—	71	90	80	71	90	80	—
	2500			0.6	0.33	1920	0.34	2082	0.37	0.9								
	3250	65	50	0.4	0.3	1920	0.29	1663	0.25	1.2	—	71	90	80	71	90	80	—
	4000			0.4	0.29	1920	0.24	1978	0.25	1.1								
	5000	80	50	0.3	0.26	1920	0.22	2217	0.25	0.9	—	71	90	80	71	90	80	—
	10000			0.1	0.2	1276	0.09	3411	0.25	0.4								



63

\* **ATTENZIONE:** la coppia massima utilizzabile  $[T_{2M}]$  deve essere calcolata utilizzando il fattore di servizio:  
 $T_{2M} = T_2 \times FS'$

\* **WARNING:** Maximum allowable torque  $[T_{2M}]$  must be calculated using the following service factor:  
 $T_{2M} = T_2 \times FS'$

\* **ACHTUNG:** das max. anwendbare Drehmoment  $[T_{2M}]$  muss mit folgendem Betriebsfaktor berechnet werden:  
 $T_{2M} = T_2 \times FS'$

**Dimensioni**

**Dimensions**

**Abmessungen**

**KXC**

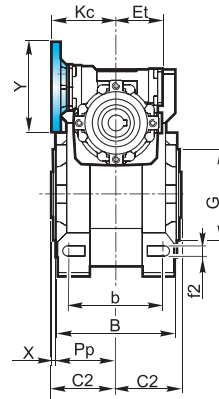
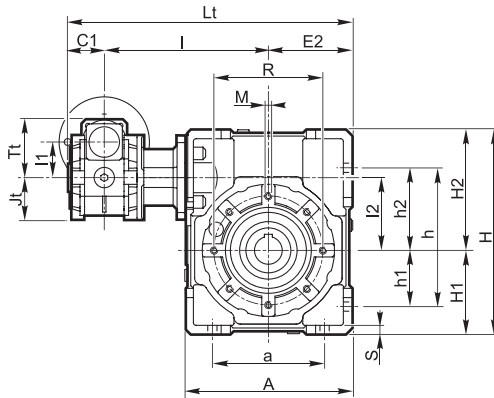

**XXA**

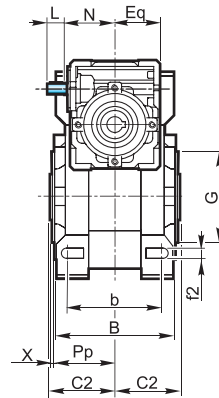
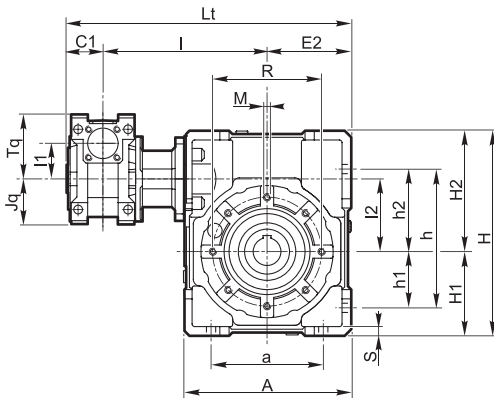

Albero entrata  
Input shaft  
Antriebswelle

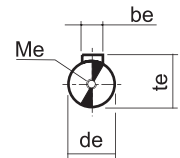

**XXF**

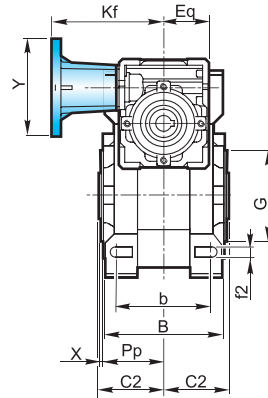
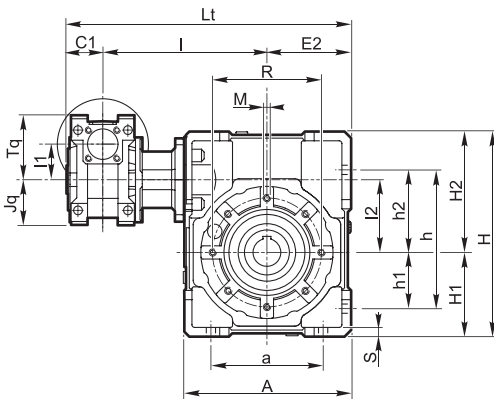

Albero uscita cavo  
Output hollow shaft  
Abtriebshohlwelle

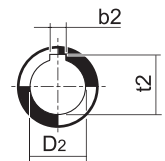

**XXC**

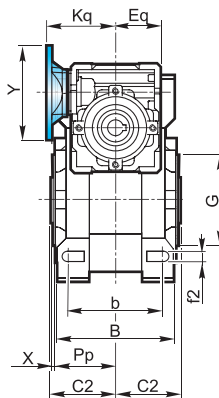
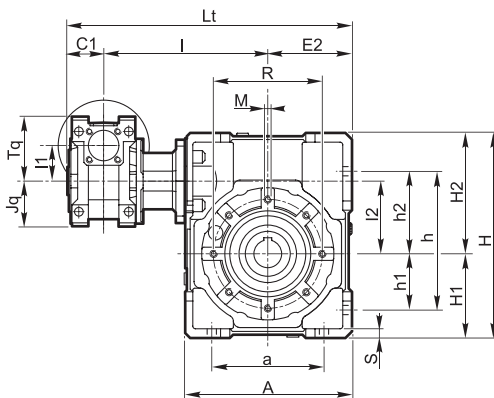

**Dimensioni**

**Dimensions**

**Abmessungen**

Flangia pendolare / Side cover for shaft mounting / Aufsteckflansch

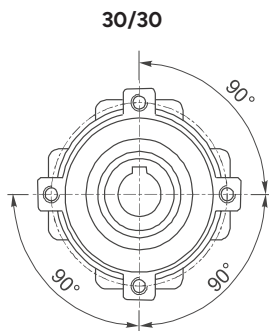

4 Fori / Holes / Bohrungen

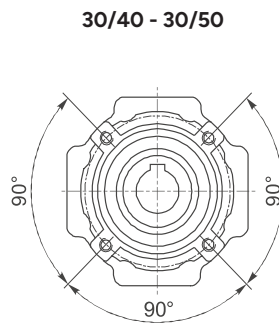

4 Fori / Holes / Bohrungen

30/63 - 40/63 - 40/75 - 40/89 -  
40/90 50/75 - 50/89 - 50/90 - 50/110  
63/110 - 63/130

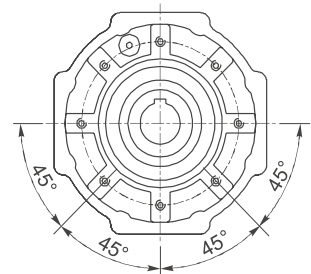

8 Fori / Holes / Bohrungen

KXC - XXC - XXF - XXA																										
	a	A	b	be	b <sub>2</sub>	B	C <sub>1</sub>	C <sub>2</sub>	de	D <sub>2</sub> H8	Et	Eq	E <sub>2</sub>	f <sub>2</sub>	G <sub>h8</sub>	h	h <sub>1</sub>	h <sub>2</sub>	H	H <sub>1</sub>	H <sub>2</sub>					
30/30	54	80	44	3	5	—	56	31.5	31.5	14	—	41	40	40	6.5	55	71	27	44	97	40	57				
30/40	70	105	60		6	6	71		39					9	18	19	50	6.5	60	90	35	55	125	50	75	
30/50	80	125	70		8	8	85		46					25	24	60	8.5	70	104	40	64	150	60	90		
30/63	100	147	85	4	8	—	103	56	11	25	—	51	50	72	9	80	130	50	80	182	72	110				
40/63														40/75	50/75	120	176	90	5	8	8	112	46	60	14	28
40/89	140	203	100	4	10	10	130	70	11	35	32	51	50	103	13	110	172	70	102	248.5	103	145.5				
50/89				5																			46	14	60	60
50/90				6																			56	77.5	19	42
50/110	170	252.5	115	6	12	—	143	56	77.5	19	42	—	71	72	127.5	14	130	210	85	125	310.5	127.5	183			
63/110	200	292.5	120	6	14	14	155	56	85	19	45	48	—	72	147.5	15	180	240	100	140	355	147.5	207.5			

KXC - XXC - XXF - XXA																						
	l	l <sub>1</sub>	l <sub>2</sub>	Jt	Jq	K <sub>c</sub>	K <sub>q</sub>	L	L <sub>t</sub>	M	Me	N	P <sub>p</sub>	R	S	Tt	Tq	t <sub>e</sub>	t <sub>2</sub>	X		
30/30	100	31.5	31.5	37.5	40	57	57	15	171.5	M6x8	M4x10	44.5	29	65	5.5	52.5	57	10.2	16.3	—	1.5	
30/40	122		40						203.5	M6x10			36.5	75	6				20.8	21.8	1.5	
30/50	132		50						223.5	M8x10			43.5	85	7				27.3	27.3	1.5	
30/63	145	63	63	43.5	50	75	75	20	248.5	M8x14	M4x12	57.5	53	95	8	68.5	75	12.5	28.3	—	2	
40/63	150								261	M8x14			57	115	10				82.5	90	16	31.3
40/75	174.5	40	75	53.5	60	82	82	25	299.5	M8x14	M5x13	67.5	57	115	10	82.5	90	16	31.3	33.3	2	
50/75	190	50							322				M8x14	57	115				10	82.5	90	16
40/89	184.5	40	90	43.5	50	75	75	20	326.5	M10x18	M4x12	57.5	67	130	12	68.5	75	12.2	38.3	35.3	2	
40/90									399.5										M10x18	67	130	12
50/89	200	50	90	53.5	60	82	82	25	349	M5x13	M5x13	67.5	82.5	90	16	82.5	90	16	45.3	—	2.5	
50/90									399.5										M5x13	67.5	82.5	90
50/110	226	63	110	64	72	97	95	30	419.5	M10x18	M8x20	77.5	74	165	14	100.5	110	21.5	45.3	—	2.5	
63/110	236	63							419.5										M10x18	77.5	74	165
63/130	256	63	130	—	72	97	95	30	459.5	M12x20	M8x20	77.5	81	215	15	—	110	21.5	48.8	51.8	3	

**Dimensioni**

**Dimensions**

**Abmessungen**

**KKC\_A**

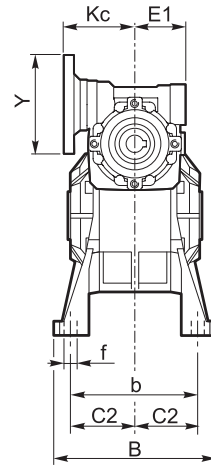
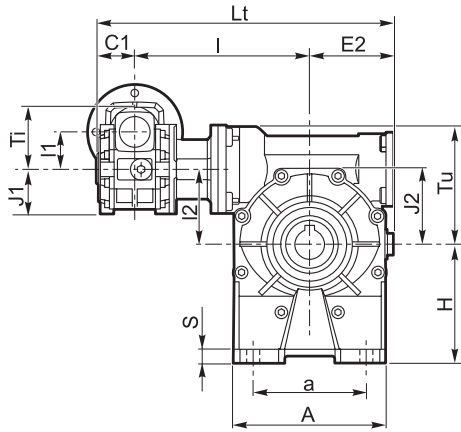

**KKC\_B**

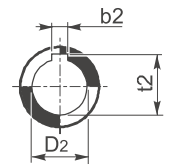
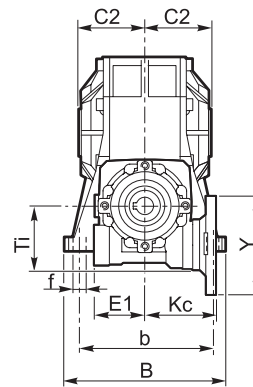
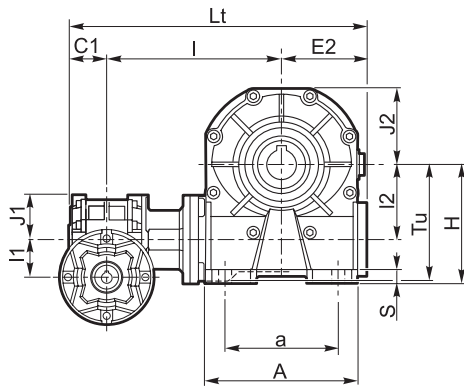

Albero uscita cavo  
Output hollow shaft  
Abtriebs-Hohlwelle

**KKC\_V**

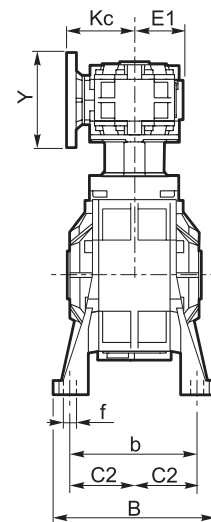
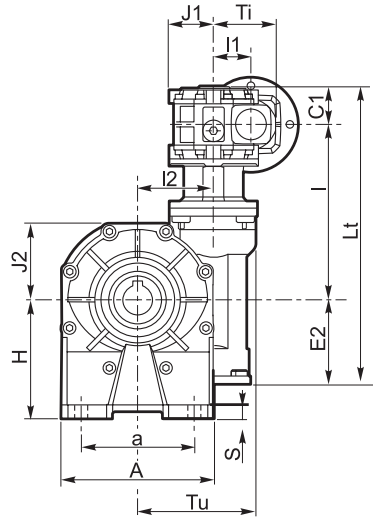

**KKC\_P**

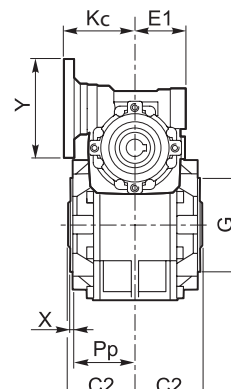
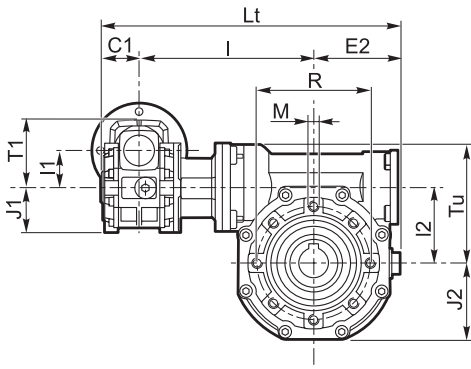

**Dimensioni**
**Dimensions**
**Abmessungen**

Flangia pendolare / Side cover for shaft mounting / Aufsteckflansch

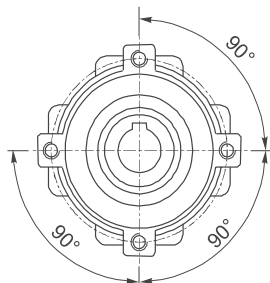
**30/30**

4 Fori / Holes / Bohrungen

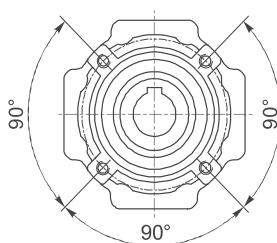
**30/40 - 30/50**

4 Fori / Holes / Bohrungen

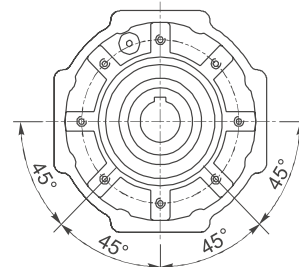
**30/63 - 40/63 - 40/75 - 40/90  
- 50/75 50/90 - 50/110 - 63/110 -  
60/130**

8 Fori / Holes / Bohrungen

	KKC																							
	A		a		B		b		f		H		S		b <sub>2</sub>	C <sub>1</sub>	C <sub>2</sub>	D2 H8	E <sub>1</sub>	E <sub>2</sub>	G h8			
	1	2	1	2	1	2	1	2	1	2	1	2	1	2										
<b>30/30</b>	67		40-52		78		66		6.5		52	55	5	8	5	—	31.5	31.5	<b>14</b>	—	41	41	55	
<b>30/40</b>	86.5		70	52	98		84	81	7	8.5	71	72	9	10	6	6		39	<b>18</b>	19		51	51	60
<b>30/50</b>	106		63-85		119		99		9		85	82	11	8	8	8		46	<b>25</b>	24		60	60	70
<b>30/63</b>	127.5		95		136		111		11		100		12	8	—		39	56	<b>25</b>	—	51	71	80	
<b>40/63</b>																								
<b>40/75</b>	155.5		120		140		115		11		115		12	8	—		46	60	<b>28</b>	30	60	85	95	
<b>50/75</b>																								
<b>40/89</b> <b>40/90</b>	190		140		168		140	146	13	11	135	142		14	10	10	39	70	<b>35</b>	32	51	103	110	
<b>50/89</b> <b>50/90</b>																								
<b>50/110</b> <b>63/110</b>																								
<b>63/110</b>	250		200		210		162	181	13	13	171	170	17	15	12	—	56	77.5	<b>42</b>	—	71	127.5	130	
<b>63/130</b>	295		235	220	229		190	191	15		200	195	20	15	14		56	85	<b>45</b>	48	71	147.5	180	

	KKC																
	I	I <sub>1</sub>	I <sub>2</sub>	J <sub>1</sub>	J <sub>2</sub>	K <sub>c</sub>	L <sub>t</sub>	M	P <sub>p</sub>	R	T <sub>i</sub>	T <sub>u</sub>	t <sub>2</sub>	X			
<b>30/30</b>	100	31.5	31.5	37.5	37.5	57	171.5	M6x8	29	65	52.5	Tu	16.3	—	1.5		
<b>30/40</b>	122		40				43.5	203.5	M6x10	36.5		75	52.5	52.5	20.8	21.8	1.5
<b>30/50</b>	132		50				53.5	223.5	M8x10	43.5		85	68.5	68.5	27.3	1.5	
<b>30/63</b>	147	40	63	64	75	82	248.5	M8x14	53	95	82.5	82.5	28.3	—	2		
<b>40/63</b>	152		43.5				261						M8x14	57	115	68.5	100.5
<b>40/75</b>	176.5	75	53.5	78	301.5	M8x14	67	130	82.5	116.5	38.3	35.3					
<b>50/75</b>	192	50		82	324								M10x18	67	130	82.5	131.5
<b>40/89</b> <b>40/90</b>	186.5	40	90	100	75	82	328.5	M10x18	67	130	68.5	116.5					
<b>50/89</b> <b>50/90</b>	202	50											53.5	82	351	M10x18	74
<b>50/110</b>	226	63	110	122	97	419.5	M10x18	74	165	100.5	161.5	45.3	—	2.5			
<b>63/110</b>	236														64	122	97
<b>63/130</b>	256	63	130	64	131	97	459.5	M12x20	81	215	100.5	181	48.8	51.8	3		

**Dimensioni**

**Dimensions**

**Abmessungen**

Flangia uscita / Output flange / Abtriebsflansch

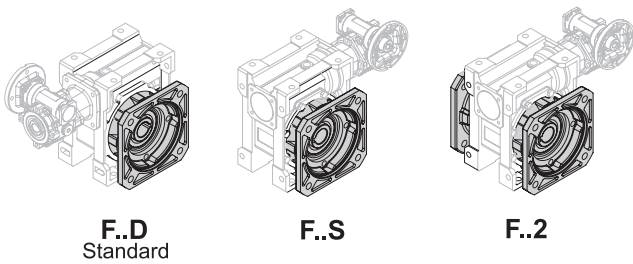
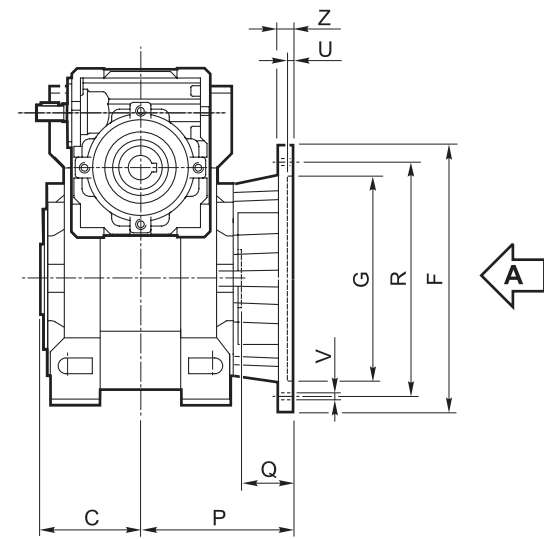

Vista da A / View from A / Ansicht von A

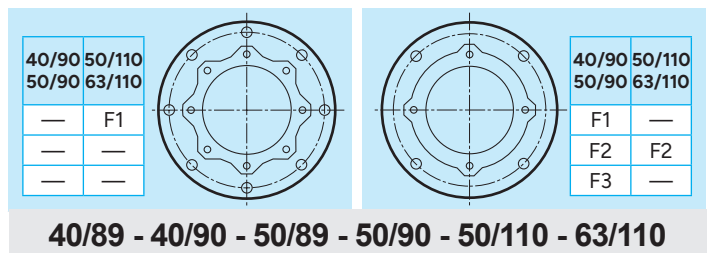
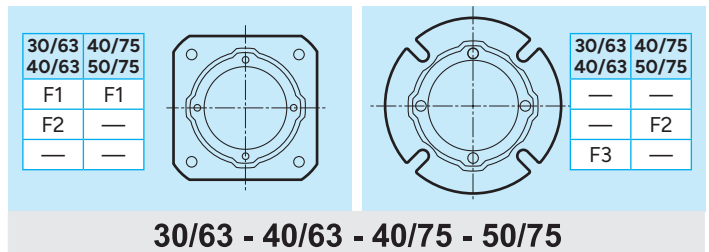
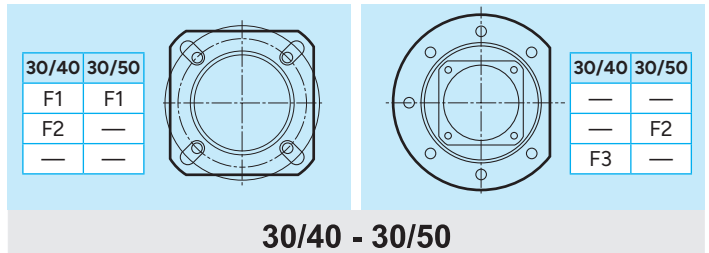
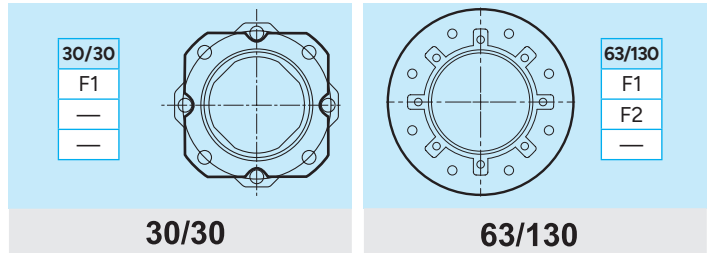

KX XX KK	Tipo Type Typ	C	F		G H8	P	Q	R	U	V			Z
30/30	F1	31.5		66	50	54.5	23	68	4			6.5	6
	F1			85	60	67	28	75-90	4			9	8
30/40	F2	39		85	60	97	58	75-90	4			9	8
	F3		140	95	80	41	115	5				9	10
30/50	F1	46		94	70	90	44	85-100	5			11	10
	F2		160	110	89	43	130	5				11	11
30/63 40/63	F1	56		142	115	82	26	150	5			11	11
	F2			142	115	112	56	150	5			11	11
	F3		160	110	80.5	24.5	130	5			11	12	
40/75 50/75	F1	60		160	130	111	51	165	5			13	12
	F2		160	110	90	30	130	6			11	13	
40/89 40/90 50/89 50/90	F1	70			152	111	41	175	5			13	12
	F2		200	152	151	81	175	5			13	13	
	F3		200	130	110	40	165	6			11	11	
50/110 63/110	F1	77.5		260	170	131	53.5	230	6			13	15
	F2		250	180	150	72.5	215	5			15	16	
63/130	F1	85		320	180	140	55	255	7			16	16
	F2		300	230	265								

\* Foratura ruotata di 22.5°

\* Drilling turned of 22.5°

\* Durchbohrung 22.5° versetzt



**Dimensioni**
**Dimensions**
**Abmessungen**

Flangia entrata / Input flange / Antriebsflansch

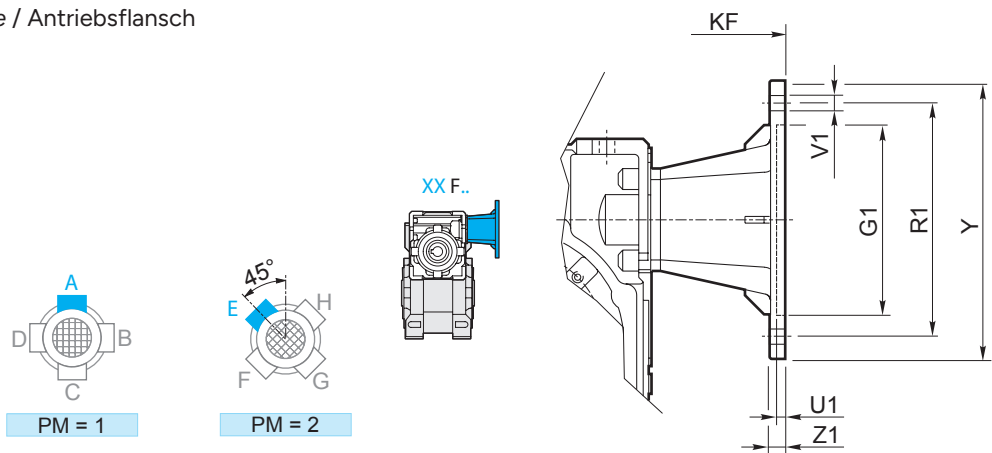

XXF	IEC	PM		G <sub>1</sub>	K <sub>F</sub>	R <sub>1</sub>	U <sub>1</sub>	Ø	V <sub>1</sub>			Y	Z <sub>1</sub>
		1	2						Ø	Ø	Ø		
30/30 30/40 30/50 30/63	56 B5	•	•	80	82.5	100	3.5	7		8		120	8
	56 B14		•	50	82.5	65	3.5	6			4	80	8
	63 B5	•	•	95	85.5	115	4	9		8		140	10
	63 B14	•	•	60	85.5	75	3.5	6		8		90	8
40/63 40/75 40/89 40/90	56 B5	•	•	80	101.5	100	3.5	7		8		120	8
	63 B5	•	•	95	104.5	115	4	9		8		140	10
	63 B14	•	•	60	104.5	75	3.5	6		8		90	8
	71 B5	•	•	110	111.5	130	4.5	9		8		160	10
	71 B14	•	•	70	111.5	85	4	7		8		105	10
50/75 50/89 50/90 50/110	63 B5	•	•	95	119.5	115	4	9		8		140	10
	71 B5	•	•	110	126.5	130	4.5	9		8		160	10
	71 B14		•	70	126.5	85	3.5	7			4	105	10
	80 B5	•	•	130	136.5	165	4.5	11		8		200	10
	80 B14	•	•	80	136.5	100	4	7		8		120	10
63/110 63/130	71 B5	•	•	110	141.5	130	4.5	9		8		160	10
	80/90 B5	•	•	130	161.5	165	4.5	11		8		200	10
	80 B14	•	•	80	151.5	100	4	7		8		120	10
	90 B14	•	•	95	161.5	115	4	9		8		140	10

**Limitatore di coppia cavo passante**

Concepito per lavorare a bagno d'olio, il dispositivo risulta affidabile nel tempo ed è esente da usura se non viene mantenuto in condizioni prolungate di slittamento (condizione che si verifica quando la coppia presenta valori superiori a quelli di taratura). La taratura è facilmente regolabile dall'esterno attraverso il serraggio di una ghiera autobloccante che porta a compressione le 4 molle a tazza disposte tra loro in serie.

Il dispositivo non consente:

- l'impiego di cuscinetti a rulli conici in uscita
- funzionamento prolungato in condizioni di slittamento.

Nella tabella seguente vengono riportati i valori delle coppie di slittamento M<sub>2S</sub> in funzione del n° di giri della ghiera.

**Torque limiter with through hollow shaft**

*Designed to be working in oil bath, the device is reliable over time and is not subject to wear unless in case of operation with prolonged slipping (it occurs when the torque values are higher than the calibration values). Calibration can be easily adjusted from outside by tightening of the self-locking ring nut, which causes the compression of the 4 Belleville washers arranged in series.*

*The device does not go together with:*

- the use of tapered roller bearings at output
- prolonged operation under slipping conditions

*The following table shows the values of M<sub>2S</sub> slipping torques depending on the number of revolutions of the ring nut.*

**Drehmomentbegrenzer mit durchgehender Hohlwelle**

Er ist zuverlässig und verschleißfrei (nur im Falle eines dauerhaften Rutschens entsteht Verschleiß, hier ist das Drehmoment größer als der eingestellte Eichwert). Die Eichung kann mühelos von aussen durch das Anziehen einer selbstsperrenden Mutter ausgeführt werden, dadurch wird der Druck auf die 4 wechselseitig angeordneten Tellerfedern erhöht.

Die Vorrichtung sieht das folgende nicht vor:

- die Verwendung von Kegelrollenlager am Abtrieb
- Längerer Rutschbetrieb

Die nachstehende Tabelle zeigt die Werte der Rutschmomente M<sub>2S</sub> abhängig von der Anzahl der Umdrehungen der Mutter. Die Eichwerte weisen ±10% Toleranz.

**Limitatore di coppia cavo passante**

**Torque limiter with through hollow shaft**

**Drehmomentbegrenzer mit durchgehender Hohlwelle**

XX-KX KK	N°. giri della ghiera di regolazione / N°. revolutions of ring nut / Nr. Umdrehungen der Mutter														
	1	1 1/4	1 1/2	1 3/4	2	2 1/4	2 1/2	2 3/4	3	3 1/4	3 1/2	3 3/4	4	4 1/4	4 1/2
30/30	20	25	30	35	40										
30/40	50	60	70	80	90										
30/50	75	95	115	135	155										
30/63		110	125	145	160	180	200	220	230	245	255	265	285		
40/63															
40/75			220	245	275	310	350	375	410	450					
50/75															
40/89 40/90				330	365	410	435	465	500	530	560	580	600	630	670
50/89 50/90															
50/110		750	860	1000	1100	1230									
63/110															
63/130															

I valori di taratura presentano una tolleranza del  $\pm 10\%$  e si riferiscono ad una condizione statica.

In condizioni dinamiche è da notare che la coppia di slittamento assume valori diversi a seconda del tipo e/o modalità in cui si verifica il sovraccarico: con valori maggiori in caso di carico uniformemente crescente rispetto a valori più contenuti in seguito al verificarsi di picchi improvvisi di carico.

**NOTA:** quando si supera il valore di taratura si ha slittamento. Il coefficiente di attrito tra le superfici di contatto da statico diventa dinamico e la coppia trasmessa cala del 30% circa. È quindi opportuno prevedere uno stop per poter ripartire al valore di taratura iniziale.

*Calibration values feature a  $\pm 10\%$  tolerance and refer to static conditions. Under dynamic conditions the values of the slipping torque will change according to the type of overload: the values are higher if the load increase is uniform; the values are lower if sudden load peaks occur.*

**NOTE:** Slipping occurs when the setting values are exceeded. The friction coefficient between the contact surfaces from static becomes dynamic and the transmitted torque is approx. 30% lower. It is advisable to have a stop first in order to have a restart based on the initial setting value.

Auf und beziehen sich auf statische Bedingungen. Unter dynamischen Bedingungen hat das Rutschmoment verschiedene Werte je nach Art der Überbelastung. Die Werte sind höher, wenn die Belastung gleichmäßig zunimmt; sie sind niedriger im Falle von plötzlichen Belastungsspitzen.

**BEMERKUNG:** Rutschen tritt auf, wenn die eingestellten Werte überschritten werden. Der Reibungskoeffizient zwischen den Berührungsflächen wird dynamisch anstatt statisch und das übertragene Drehmoment sinkt um ca. 30%. Es ist daher ratsam, vor dem erneuten Anfahren anzuhalten, um die ursprünglichen Drehmomentwerte zu erreichen.

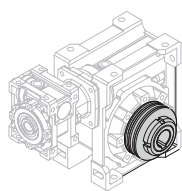
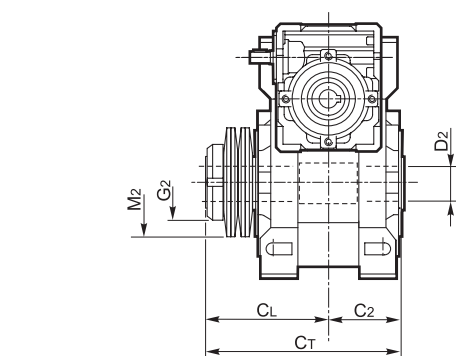

**LD**

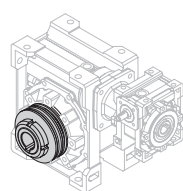

**LS**

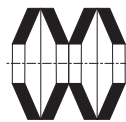

Disposizione delle molle  
Washers' arrangement  
Lage der Feder

**IN SERIE** (min. coppia, max. sensibilità)  
**SERIES** (min. torque, max sensitivity)  
**SERIE** (min. Moment, max. Empfindlichkeit)

XX - KX LD - LS	C <sub>2</sub>	C <sub>L</sub>	C <sub>t</sub>	D <sub>2</sub> H8	G <sub>2</sub>	M <sub>2</sub>
30/30	31.5	55.5	87	14	M25x1.5	50x25.4x1.5
30/40	39	65	104	18 (19)	M30x1.5	56x30.5x2
30/50	46	76	122	25 (24)	M40x1.5	63x40.5x2.5
30/63						
40/63	56	91	147	25	M40x1.5	71x40.5x2.5
40/75						
50/75	60	100	160	28 (30)	M50x1.5	90x50.5x3.5
40/89 - 40/90						
50/89 - 50/90	70	109	179	35 (32)	M50x1.5	100x51x3.5
50/110						
63/110	77.5	127.5	205	42	M60x2	125x61x5
63/130						

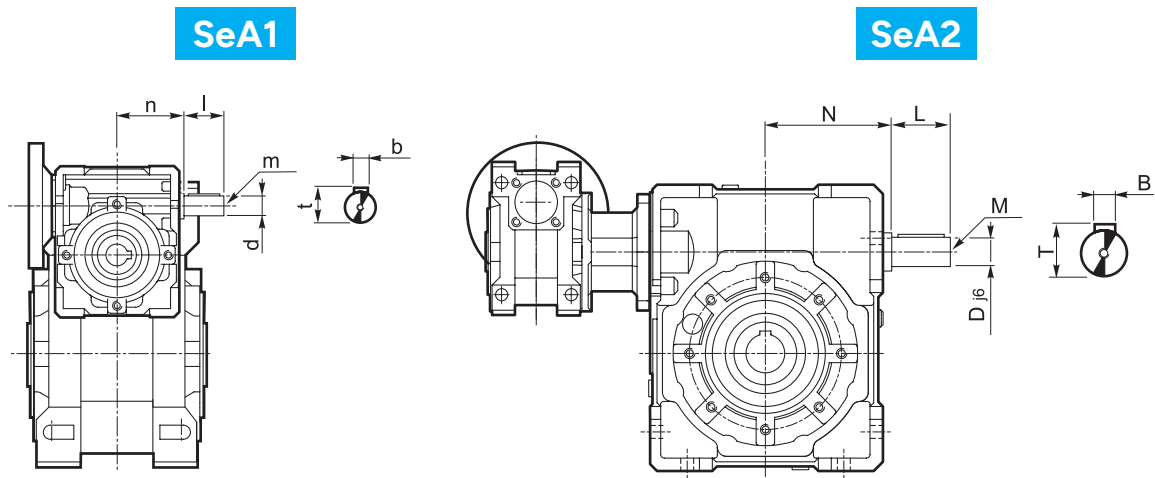

L'entrata supplementare del riduttore in uscita (SeA2) non può essere utilizzata come comando in quanto il relativo movimento risulta impedito dalla irreversibilità del primo riduttore. Utilizzato come asse condotto, avrà velocità corrispondente a quella di ingresso ridotta del rapporto del primo riduttore.

*The second input shaft of the output gearbox (SeA2) can not be utilized as a drive because its motion will be stopped by the reversibility of the first gearbox. If utilized as a drive shaft its speed will be equal to the input speed decreased by the ratio of the first gearbox.*

Die verlängerte Schneckenwelle des zweiten Getriebes (SeA2) kann nicht als Antrieb verwendet werden, da die Selbsthemmung des ersten Getriebes entgegengewirkt. Wird sie als Abtriebswelle verwendet, besitzt sie eine um die Untersetzung des ersten Getriebes entsprechend reduzierte Drehzahl und Drehmoment.

KXC - XXC XXF - XXA KKC	SeA1							SeA2						
	b	d j6	l	m	n		t	B	D j6	L	M	N		T
					KK-KX	XX						KK	KX-XX	
30/30	3	9	15	M4x10	42.5	42.5	10.2	3	9	15	M4x10	42.5	42.5	10.2
30/40	3	9	15	M4x10	42.5	42.5	10.2	4	11	20	M4x12	52.5	52.5	12.5
30/50	3	9	15	M4x10	42.5	42.5	10.2	5	14	25	M5x13	62.5	62.5	16
30/63	3	9	15	M4x10	42.5	42.5	10.2	6	19	30	M8x20	72.5	74.5	21.5
40/63	4	11	20	M4x12	52.5	52.5	12.5	6	19	30	M8x20	72.5	74.5	21.5
40/75	4	11	20	M4x12	52.5	52.5	12.5	8	24	40	M8x20	89	91	27
50/75	5	14	25	M5x13	62.5	62.5	16	8	24	40	M8x20	89	91	27
40/89 40/90	4	11	20	M4x12	52.5	52.5	12.5	8	24	40	M8x20	108	108	27
50/89 50/90	5	14	25	M5x13	62.5	62.5	16	8	24	40	M8x20	108	108	27
50/110	5	14	25	M5x13	62.5	62.5	16	8	28	50	M8x20	132	132	31
63/110	6	19	30	M8x20	72.5	74.5	21.5	8	28	50	M8x20	132	132	31
63/130	6	19	30	M8x20	72.5	74.5	21.5	10	38	70	M10x25	152	152	41

### Accessori

### Accessories

### Zubehör

#### Albero lento

Albero lento semplice  
Single output shaft  
Standard Abtriebswelle

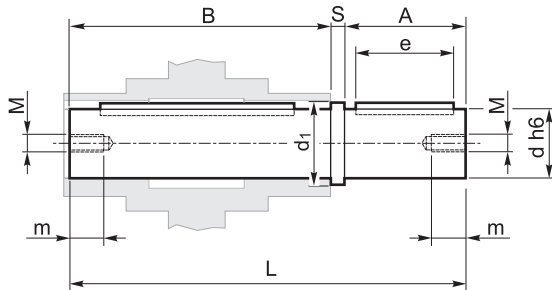

#### Output shaft

#### Abtriebswelle

Albero lento doppio  
Double output shaft  
Doppelte Abtriebswelle

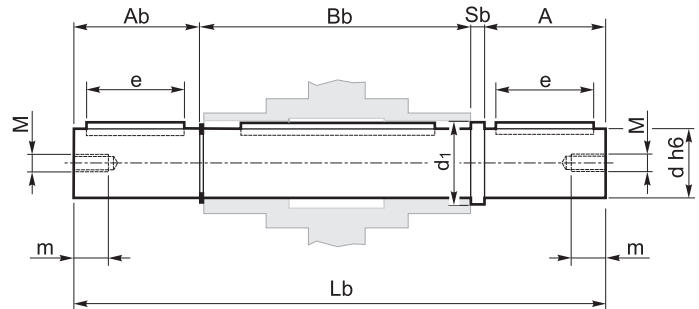

KK-KX-XX	A	B	d <sub>h6</sub>	d <sub>1</sub>	e	L	M	m	S	A	A <sub>b</sub>	B <sub>b</sub>	d <sub>h6</sub>	d <sub>1</sub>	e	L <sub>b</sub>	S <sub>b</sub>
30/30	30	62	14	18.5	20	94.5	M6	16	2.5	30	29	64	14	18.5	20	126	2.5
30/40	40	77	18	19	23.5	120	M6	16	3	40	39	79	18	23.5	30	161	3
30/50	50	90	25	24	31.5	143.5	M8	22	3.5	50	49	93	25	31.5	40	195.5	3.5
30/63 40/63	50	111	25	31.5	40	165	M8	22	4	50	49	113	25	31.5	40	216	4
40/75 50/75	60	119	28	30	34.5	183	M8	22	4	60	59	121	28	34.5	50	244	4
40/89 - 40/90 50/89 - 50/90	80	139	35	41.5	60	224	M10	28	5	80	78.5	141.5	35	41.5	60	305	5
50/110 63/110	80	154.5	42	49.5	60	242.5	M10	28	8	80	77.5	157	42	49.5	60	322.5	8
63/130	80	168	45	54.5	70	253	M16	36	5	80	78	172	45	54.5	70	335	5

#### Braccio di reazione

#### Torque arm

#### Drehmomentstütze

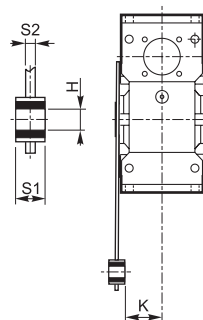
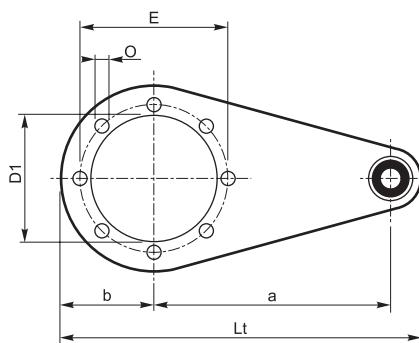

KK KX XX	a	b	D <sub>1</sub>	E	H	K	L <sub>t</sub>	O	S1	S2
30/30	85	37.5	55	65	8	24	141.5	7	14	4
30/40	100	45	60	75	10	31.5	167	7	14	4
30/50	100	50	70	85	10	39	172	9	14	5
30/63 40/63	150	55	80	95	10	49	227	9	14	6
40/75 50/75	200	70	95	115	20	47.5	302	9	25	6
40/89 - 40/90 50/89 - 50/90	200	80	110	130	20	57.5	312	11	25	6
50/110 63/110	250	100	130	165	25	62	390	11	30	6
63/130	250	125	180	215	25	69	415	13	30	6

#### Kit di protezione solo su versione P

#### Protection Kit only for P Version

#### Schutzvorrichtung nur für Version P

Albero cavo / Hollow shaft / Hohlwelle

Limitatore di coppia / Torque limiter / Drehmomentbegrenzer

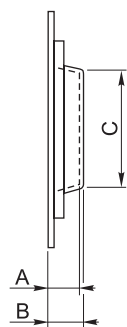

KK KX XX	A		B		C	
	IN	OUT	IN	OUT	IN	OUT
30/30		12		13		39
30/40	12	14	13	15.5	39	44
30/50		15		16.5		54
30/63		17		19		60
40/63	14		15.5		44	
40/75		18		20		70
50/75	15		16.5		54	
40/89 - 40/90 50/89 - 50/90	14	21.5	15.5	24	44	80
50/110	15		16.5		54	
63/110	17	22	19	25	60	96
63/130	17	22	19	25	60	130

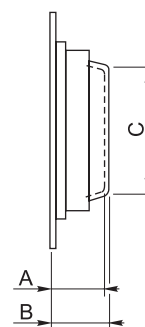

KK KX XX	A		B		C	
	IN	OUT	IN	OUT	IN	OUT
30/30		36		37		36
30/40	36	40	37	41.5	36	44
30/50		47		48.5		53
30/63		52		54		55
40/63	40		41.5		44	
40/75		58		60		68
50/75	47		48.5		53	
40/89 - 40/90 50/89 - 50/90	40	60.5	41.5	63	44	70
50/110	47		48.5		53	
63/110	52	72	54	75	55	85
63/130	52		54		55	

#### Opzioni disponibili:

#### Available options:

#### Auf Anfrage ist folgendes Zubehör erhältlich:

Cuscinetti a rulli conici corona

Tapered roller bearing on wormgear

Kegelrollenlager auf Schneckenrad

**KXC - XXC - XXA - XXF - KKC**

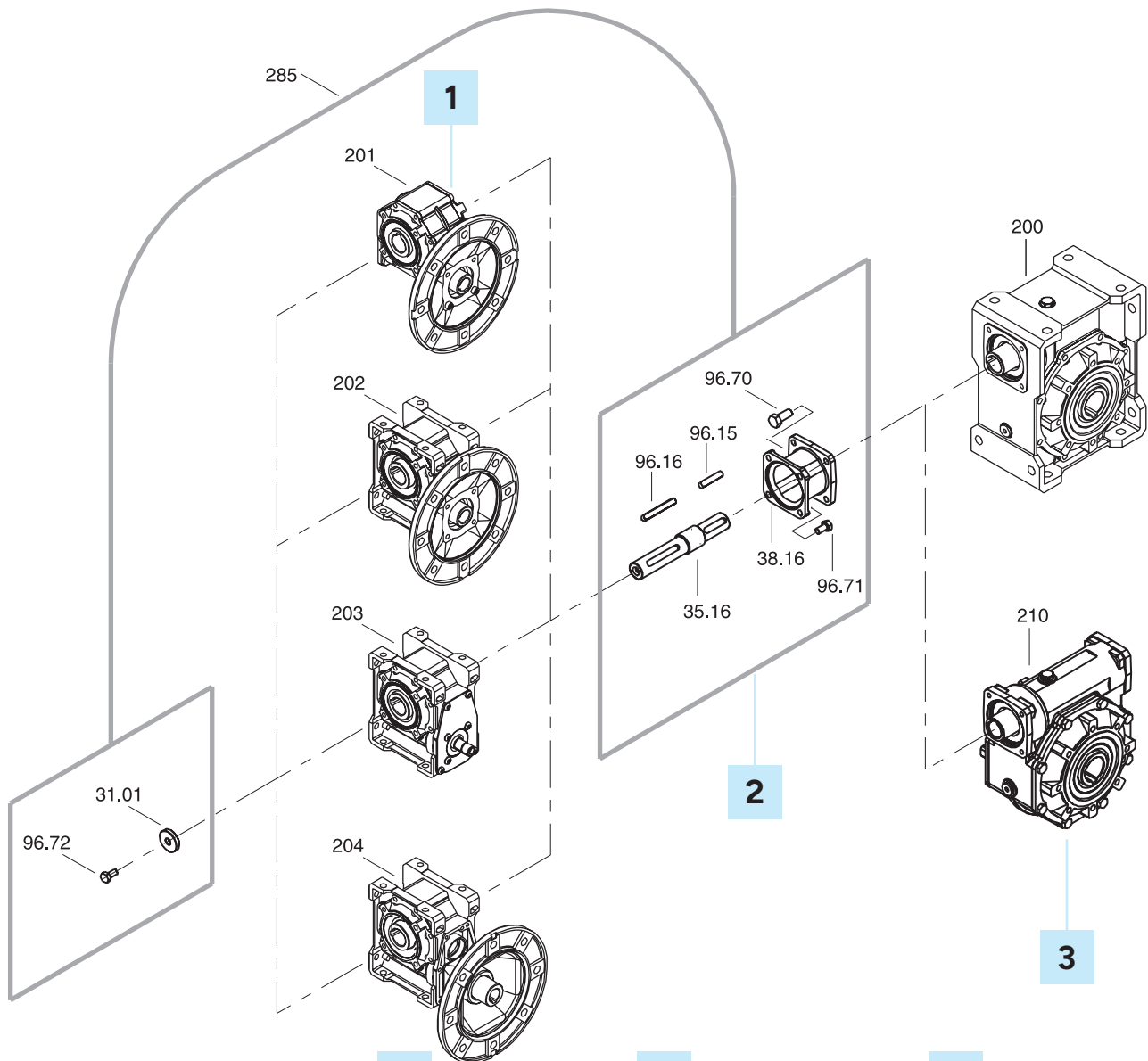

**1**

**2**

**3**

30/30
30/40
30/50
30/63
40/63
40/75
40/89 - 40/90
50/75
50/89 - 50/90
50/110
63/110
63/130

IN X..P - K..P
<b>X30 KC30</b>
<b>X40 KC40</b>
<b>X50 KC50</b>
<b>X63 KC63</b>
<b>X63 KC63</b>

KIT
KIT 30/30 (2850002010)
KIT 30/40 (2850002013)
KIT 30/50 (2850002016)
KIT 30/63 (2850002019)
KIT 40/63 (2850002028)
KIT 40/75-90 (2850002031)
KIT 50/75-90 (2850002034)
KIT 50/110 (2850002049)
KIT 63/110-130 (2850002052)
KIT 63/110-130 (2850002052)

OUT XC - KC
<b>30/9</b>
<b>40/11</b>
<b>50/14</b>
<b>63/19</b>
<b>63/19</b>
<b>75/24</b>
<b>90/24</b>
<b>75/24</b>
<b>90/24</b>
<b>110/28</b>
<b>110/28</b>
<b>110/28</b>

Lista parti di ricambio

Spare parts list

Ersatzteilliste

**X - H - K - KX - XX - KK**

Limitatore di coppia cavo passante

Torque limiter with through hollow shaft

Drehmomentbegrenzer mit durchgehende Hohlwelle

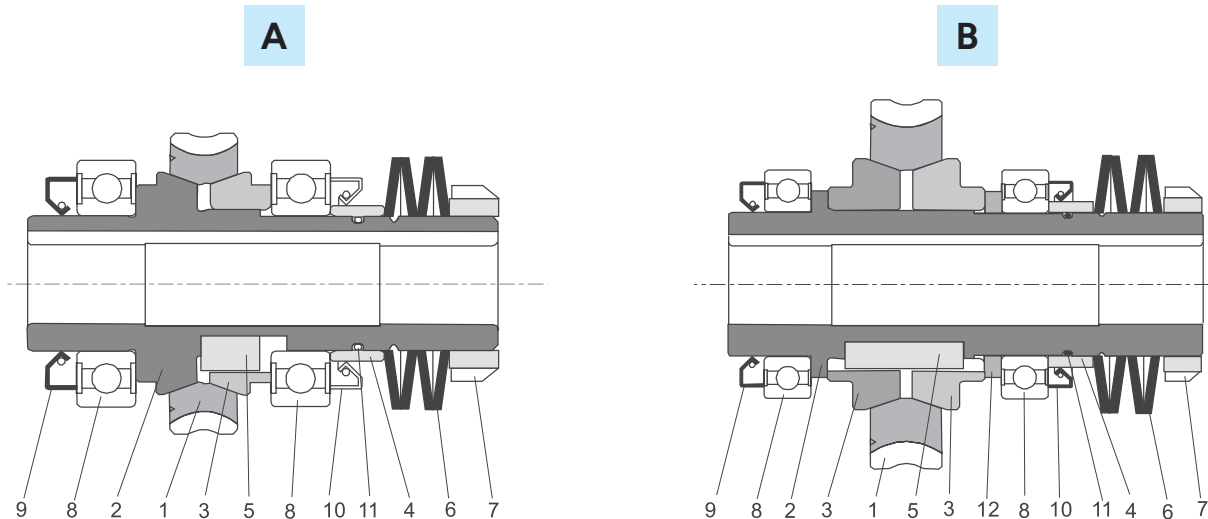

A			B				
<b>X - H - K</b>							
30 (LD - LS)	40 (LD - LS)	50 (LD - LS)	63 (LD - LS)	75 (LD - LS)	90 (LD - LS)	110 (LD - LS)	130 (LD - LS)
<b>KX - XX - KK</b>							
30/30 (L1-LD-LS) 30/40 (L1) 30/50 (L1) 30/63 (L1)	30/40 (LD - LS) 40/63 (L1) 40/75 (L1) 40/89 (L1) 40/90 (L1)	30/50 (LD - LS) 50/75 (L1) 50/89 (L1) 50/90 (L1) 50/110 (L1)	30/63 (LD - LS) 40/63 (LD - LS) 63/110 (L1)	40/75 (LD - LS) 50/75 (LD - LS)	40/90 (LD - LS) 50/90 (LD - LS)	50/110 (LD - LS) 63/110 (LD - LS)	63/130 (LD - LS)
1	Corona in bronzo / Bronze wheel / Bronzerad /						
2	Albero cavo limitatore / Hollow shaft torque limiter / Rutschkupplungs-Hohlwelle						
3	Anello di frizione / Friction ring / Reibring						
4	Distanziale molle / Washers' distance ring / Federdistanzring						
5	Linguetta / key / Passfeder						
	8x7x10AB	10x8x13AB	12x8x18AB	12x8x40A	16x10x40A	16x10x50A	18x11x60A
6	Molle a tazza / Belleville washers / Tellerfeder						
7	Ghiera / Metal ring / Metall Ring						
8	6005 25x47x12	6006 30x55x13	6008 40x68x15	6008 40x68x15	6010 50x80x16	6010 50x80x16	6012 60x95x18
9	25x40x7	30x47x7	40x62x8	40x62x8	50x72x8	50x72x8	60x85x8
10	30x40x5	35x47x7	48x62x8	48x62x8	58x72x8	58x72x8	70x85x8
11	OR2087 21.95x1.78	OR2106 26.7x1.78	OR 36.27x1.78	OR 36.27x1.78	OR2187 47.37x1.78	OR2187 47.37x1.78	OR2225 56.87x1.78
12	Distanziale / Spacer / Abstandshülse						

**Targhetta**
**Plate**
**Schild**

In fase di ordine delle parti di ricambio, specificare sempre n° particolare (vedi disegno esploso), data (1), n° codice (2) e n° variante (3). (Vedi targhetta).

When ordering please specify the spare part number (see exploded view) as well as the date (1), the article number (2) and the variant number (3). (see plate)

Bei der Bestellung von Ersatzteilen sind Ersatzteilnummer (s. Explosionszeichnung), Datum (1), Artikelnummer (2) und Variantenummer (3) anzugeben. (s. Schild)

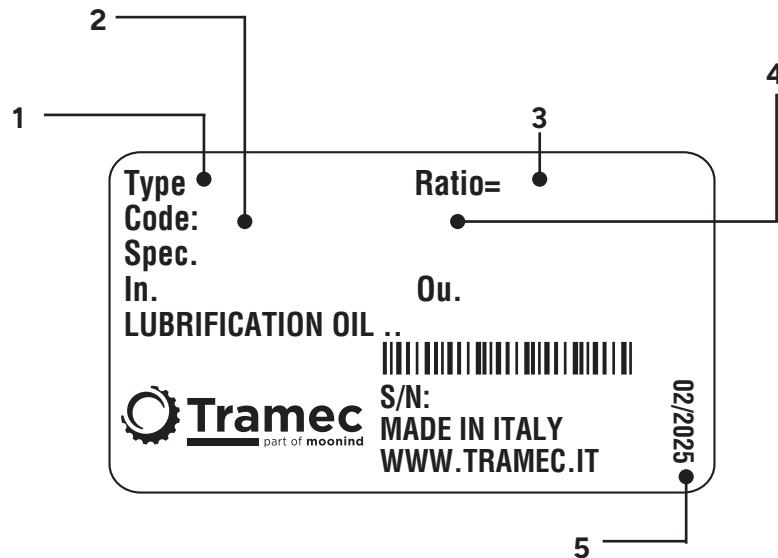

1	TIPO: descrizione	TYPE: description	TYP: Bezeichnung
2	CODICE: distinta base	CODE: base list	ART.-Nr.: Basisstückliste
3	RAP: rapporto di riduzione	RATIO: reduction ratio	ÜBERS: Untersetzungsverhältnis
4	VARIANTE: codice alfanumerico	MODEL: alphanumeric code	VARIANTE: alphanumerische Nummer
5	DATA: mese/anno	DATE: month/year	DATUM: Monat/Jahr

**RIDUTTORI A VITE  
SENZA FINE CON  
DOPPIA USCITA**
**DOUBLE OUTPUT  
WORM  
GEARBOXES**
**SCHNECKENGETRIEBE  
MIT ZWEI  
AUSGANGSWELLEN**
**VM**

Caratteristiche	<i>Characteristics</i>	Merkmale	<b>F2</b>
Designazione	<i>Designation</i>	Bezeichnung	<b>F2</b>
Lubrificazione	<i>Lubrication</i>	Schmierung	<b>F3</b>
Carichi radiali e assiali	<i>Radial and axial loads</i>	Radial und axial Belastungen	<b>F3</b>
Dati tecnici	<i>Technical data</i>	Technische Daten	<b>F4</b>
Dimensioni	<i>Dimensions</i>	Abmessungen	<b>F5</b>
Lista parti di ricambio	<i>Spare parts list</i>	Ersatzteilliste	<b>F7</b>
Targhetta	<i>Plate</i>	Schild	<b>F11</b>



## Caratteristiche

La serie di vite senza fine con doppia uscita comprende riduttori costruiti appositamente per soddisfare delle specifiche esigenze di automazione. Il cinematismo, composto da una vite senza fine e due corone, consente di disporre, all'uscita, di due alberi cavi con una rotazione sincrona controrotante. La motorizzazione può essere effettuata tramite motori elettrici o motorizzatori provvisti di una flangia di fissaggio dimensionata a norme IEC.

- **Corpo e flange**  
Costruiti in alluminio e verniciati colore BLU RAL 5010
- **Vite senza fine**  
In acciaio legato. Indurita tramite cementazione e tempra e finita di rettifica
- **Corona**  
Fascia dentata in bronzo GcuSn12 UNI 7013 riportata di fusione su mozzo in ghisa G20 UNI 5007
- **Cuscinetti**  
Sulla vite e sulle due uscite sono montati cuscinetti a rulli conici
- **Lubrificazione**  
Normalmente i riduttori vengono forniti privi di lubrificante. Su richiesta possono essere forniti con lubrificante sintetico

## Characteristics

*Double output worm gearboxes series includes gearboxes specially manufactured to comply with specific requirements. The kinematic motion is carried out by means of a wormshaft and two wormwheels in order to have two output shafts with a synchronous rotation. These gearboxes can be assembled to electric motors or moto variators fully comply with the IEC specifications.*

- **Casing and flanges**  
*Made from aluminium and painted BLUE RAL 5010*
- **Worm screw**  
*Made from alloy steel. Hardened and case-hardened then finished by grinding*
- **Worm wheel**  
*UNI 7013 GcuSn12 bronze toothed band. Inserted by casting on UNI 5007 G20 cast-iron hub.*
- **Bearings**  
*Taper roller bearings are mounted on the screw and on the two outputs*
- **Lubrication**  
*Gearboxes are normally supplied without lubricant. However, they can be supplied with synthetic lubricant on request*

## Merkmale

Bei der Schneckengetriebe mit Zwei Ausgangswellen Serie handelt es sich um Schneckengetriebe, die für spezielle Antriebsaufgaben eingesetzt werden. Der Aufbau besteht aus einer Schneckewelle und zwei Schneckenräder umgewandelt. Der Antrieb erfolgt durch IEC Normmotoren oder Verstelltriebemotoren.

- **Gehäuse und Flansche**  
Aus Aluminium gefertigt und mit Farbe BLAU RAL 5010 lackiert
- **Schnecke**  
Aus legiertem Stahl. Gehärtet durch Einsatzhärtung und Abschreckhärtung mit Fertigschliff
- **Zahnkranz**  
Zahnband aus Bronze GcuSn 12 UNI 7013, aufgegossen auf Nabe aus Guss-eisen G20 UNI 5007
- **Lager**  
Auf der Schnecke und auf den beiden Abtrieben werden Kegelrollenlager montiert.
- **Schmierung**  
Normalerweise werden die Getriebe ohne Schmiermittel geliefert. Auf Anfrage können sie mit synthetischem Schmiermittel geliefert werden

## Designazione

## Designation

## Bezeichnung

Riduttore Gearbox Getriebe	Tipo entrata Input type Antriebsart	Grandezza Size Größe	Rapporto rid. Ratio Untersetzung	Predispos.att. mot. Motor coupling Motoranschluss
<b>VSF.2USC.</b>	<b>VM</b>	<b>135</b>	<b>40</b>	<b>pam 200/19</b>
	<b>VM VI</b>	<b>135 150 170 230</b>	<b>i</b>	

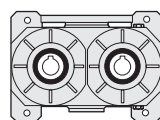

### Lubrificazione

Normalmente i riduttori vengono forniti privi di lubrificante. I tappi sono predisposti come da disegno.

### Lubrication

The gearboxes are normally supplied without lubricant. The filler plugs are arranged as shown in the drawing.

### Schmierung

Normalerweise werden die Getriebe ohne Schmiermittel geliefert. Die Anbringung der Füllstopfen entspricht der Zeichnung.

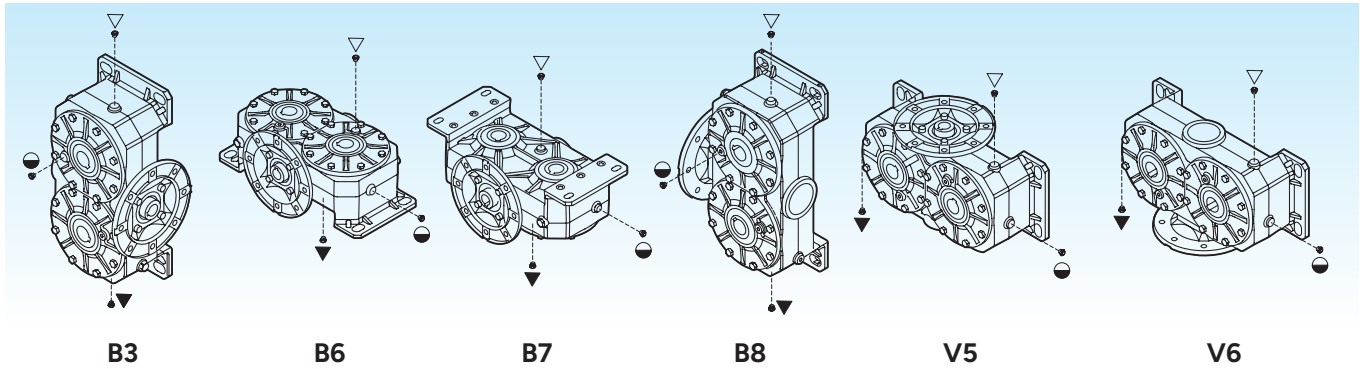

- ▽ Carico e sfiato / Filling and breather  
Einfüll und Entlüftung
- Livello / Level / Ölstand
- ▼ Scarico / Drain / Ablass

		Q.tà olio / Oil quantity / Schmiermittelmenge [lt]				
		Posizione di montaggio / Mounting position / Einbaulage				
		B3	B6	B7	B8	V5 - V6
VM	135	0.8	0.6	0.6	0.8	0.5
	150	1.5	1.2	1.2	1.5	1
	170	2	1.5	1.5	2	1.2
	230	5	4.5	3.5	5	3.2

### Carichi radiali e assiali

Nella tabella sono indicati i valori, espressi in N, dei carichi radiali e assiali ammissibili su ogni singola uscita. Il carico radiale  $F_{r2}$  si considera applicato ad una distanza dalla battuta dell'albero cavo pari al valore del diametro. I valori indicati hanno come limite la struttura del riduttore, perciò non variano al diminuire della velocità, cosa che normalmente avviene quando il limite è riferito ai cuscinetti.

### Radial and axial loads

In the table, the permissible radial and axial loads for each individual output are shown as N. The radial load  $F_{r2}$  should be considered as applied at a distance from the shaft shoulder equal to the diameter figure. The listed values are limited by the gear drive structure, therefore, they will not change as the speed decreases, which is normally the case when bearings are the limit reference.

### Radial und Axial Belastungen

In der Tabelle werden die Werte der auf jedem einzelnen Abtrieb zulässigen Radial- und Axialbelastungen in N angegeben. Hinsichtlich der radialen Belastung  $F_{r2}$  wird von einem Abstand vom Anschlag der Hohlwelle ausgegangen, der dem Wert des Durchmessers entspricht. Die angegebenen Werte werden durch die Struktur des Getriebes beschränkt und verändern sich daher bei Reduzierung der Drehzahl nicht. Dies ist normalerweise dann der Fall, wenn der Grenzwert sich auf die Lager bezieht.

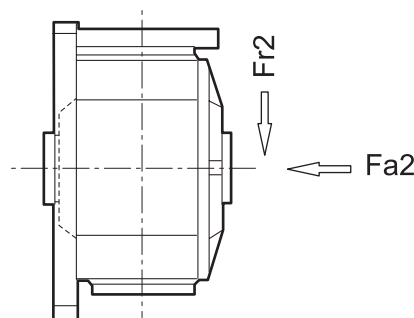

Tipo Size Typ	135	150	170	230
$F_{r2}$ [N]	1200	1900	1700	3000
$F_{a2}$ [N]	600	950	850	1500

**Dati tecnici**
**Technical data**
**Technische Daten**

			135	150		170		230		
Tipo Size Typ			13	15.5		19		40		
		i	40	7.5	40	40	80	10	28	40
<b>VM</b>	$n_1 = 1400$ rpm	$n_2$ [rpm]	35	187	35	35	17.5	140	50	35
		$P_1$ [kW]	0.75	1.8	0.75	1.8	1.5	5.5	4	1.8
		$T_2$ [Nm]	66	37	65	160	221	149	268	160
		$F_s$	2	3.7	2.6	1.4	1	2.7	1.6	2.8
<b>VI</b>	$n_1 = 1400$ rpm	$n_2$ [rpm]	35	/	/	35	17.5	/	/	/
		$P_1$ [kW]	1.5	/	/	2.6	1.5	/	/	/
		$T_2$ [Nm]	131	/	/	234	218	/	/	/
		$\eta_D$	0.64	/	/	0.65	0.54	/	/	/
	$n_1 = 900$ rpm	$n_2$ [rpm]	23	/	/	23	11	/	/	/
		$P_1$ [kW]	1.2	/	/	2	1.1	/	/	/
		$T_2$ [Nm]	158	/	/	269	247	/	/	/
		$\eta_D$	0.60	/	/	0.62	0.51	/	/	/
	$n_1 = 500$ rpm	$n_2$ [rpm]	12.5	/	/	12.5	6	/	/	/
		$P_1$ [kW]	0.8	/	/	1.4	0.8	/	/	/
		$T_2$ [Nm]	186	/	/	317	288	/	/	/
		$\eta_D$	0.56	/	/	0.57	0.46	/	/	/
		$\eta_S$	0.43	0.70	0.44	0.45	0.33	0.69	0.49	0.42

 La coppia  $T_2$  è riferita a ciascuna uscita.  $T_2$  torque refers to each output

 $T_2$  bezieht sich auf jedes Abtrieb

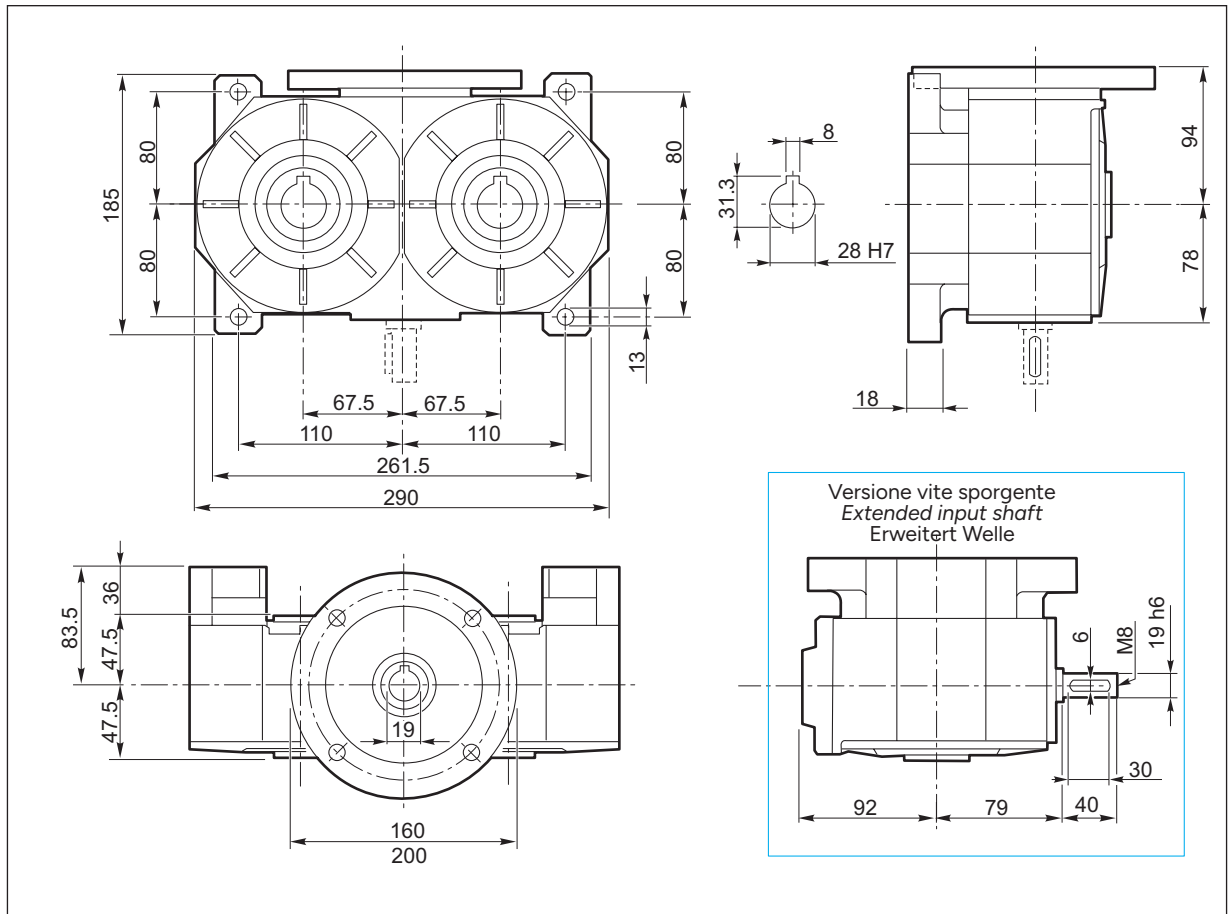
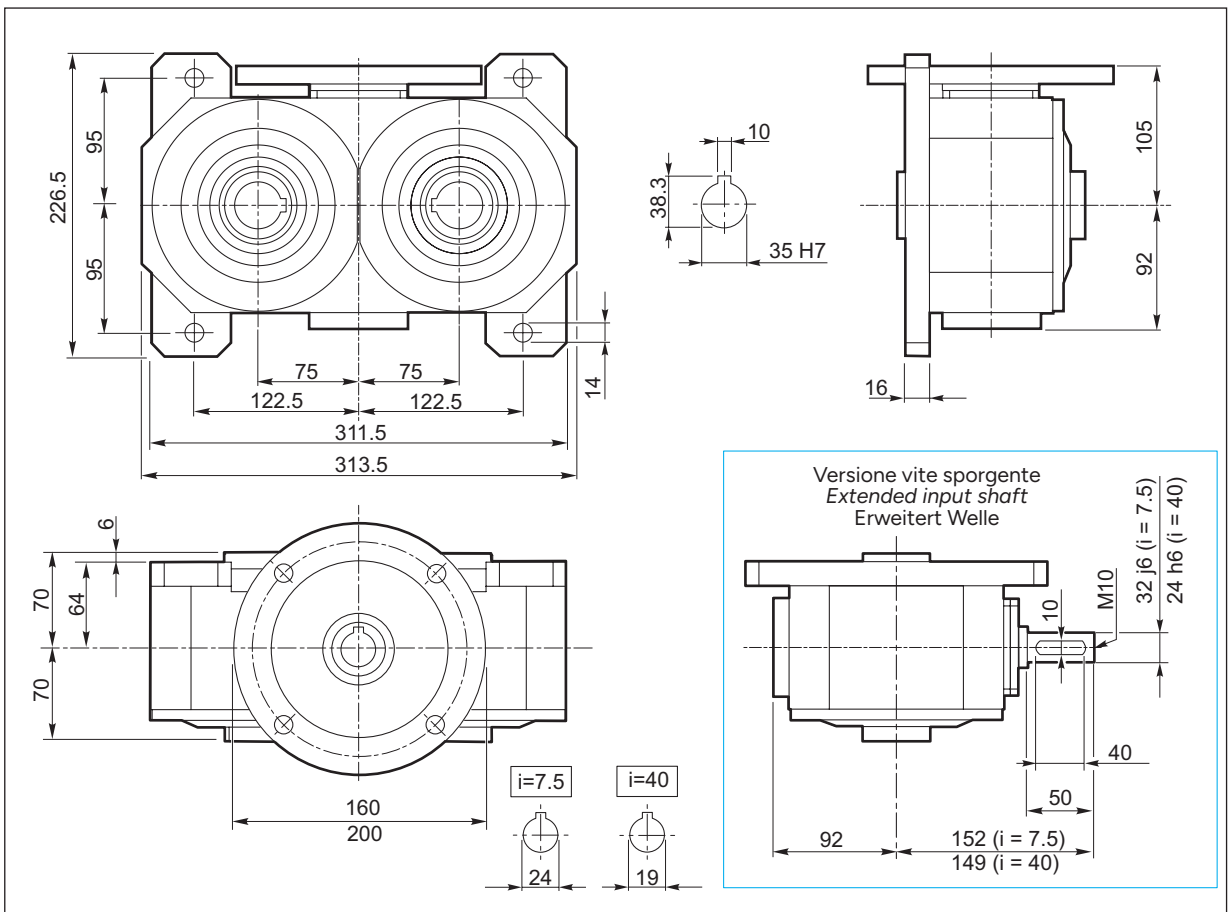
**Dimensioni**
**Dimensions**
**Abmessungen**
**135**

**150**

**Dimensioni**

**Dimensions**

**Abmessungen**

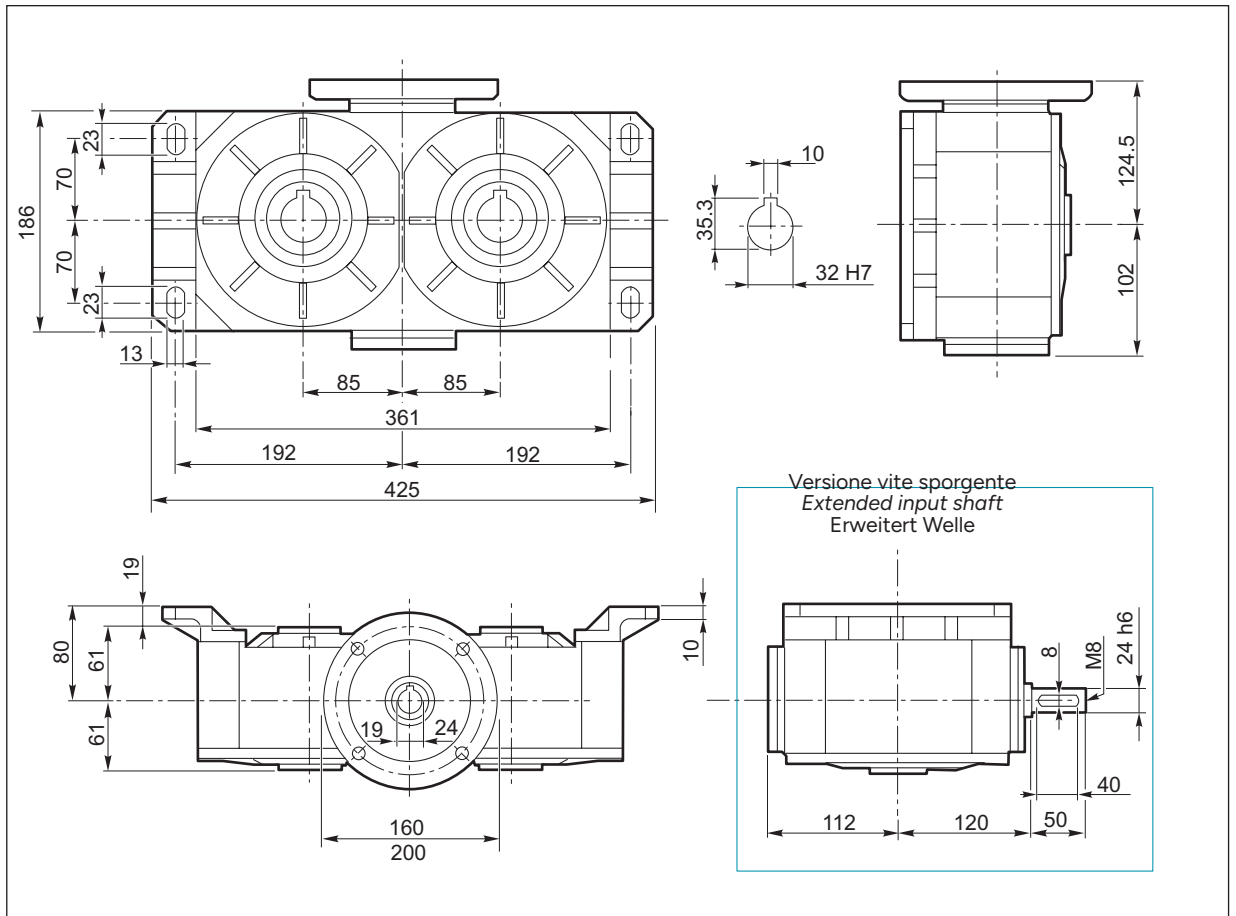
**170**



**230**

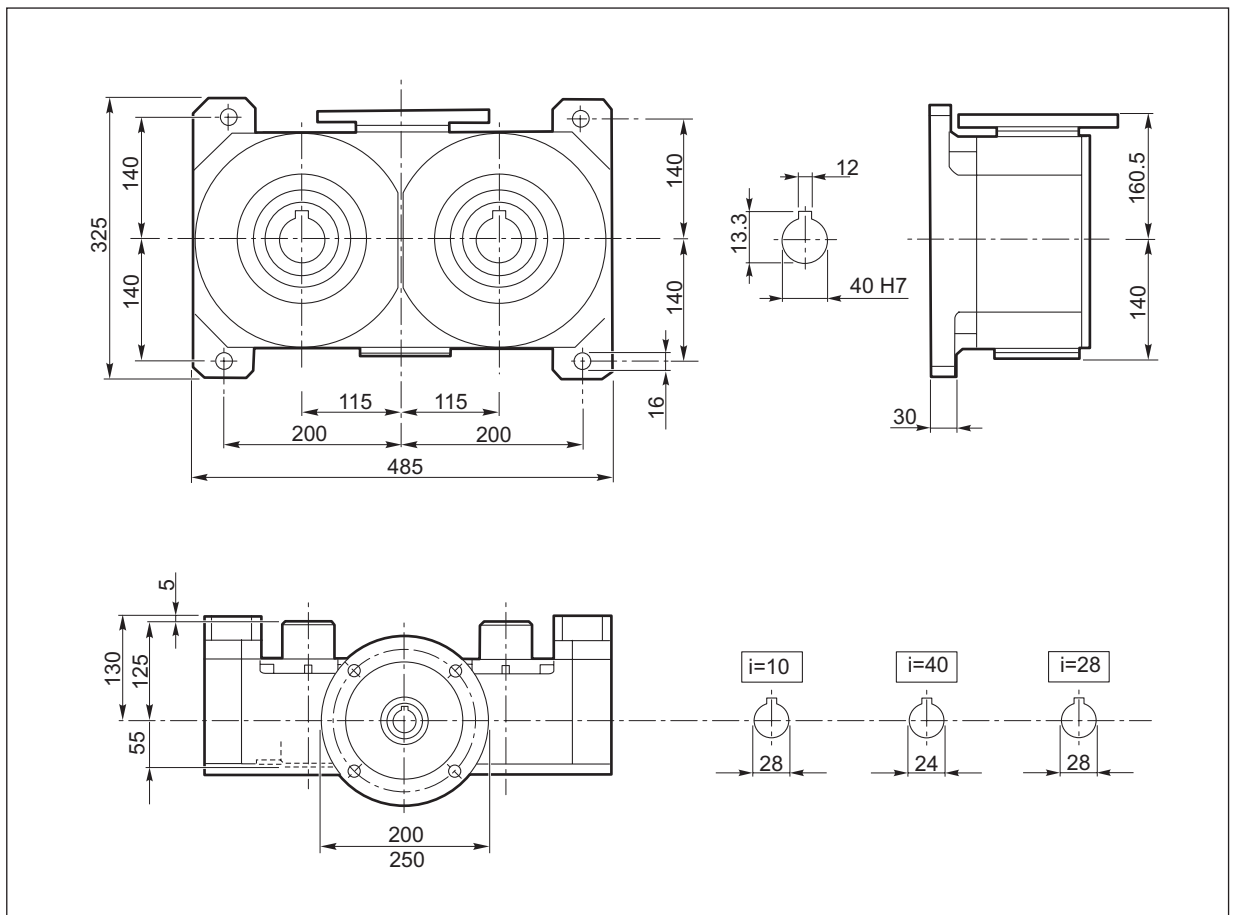





## VM - VI 170

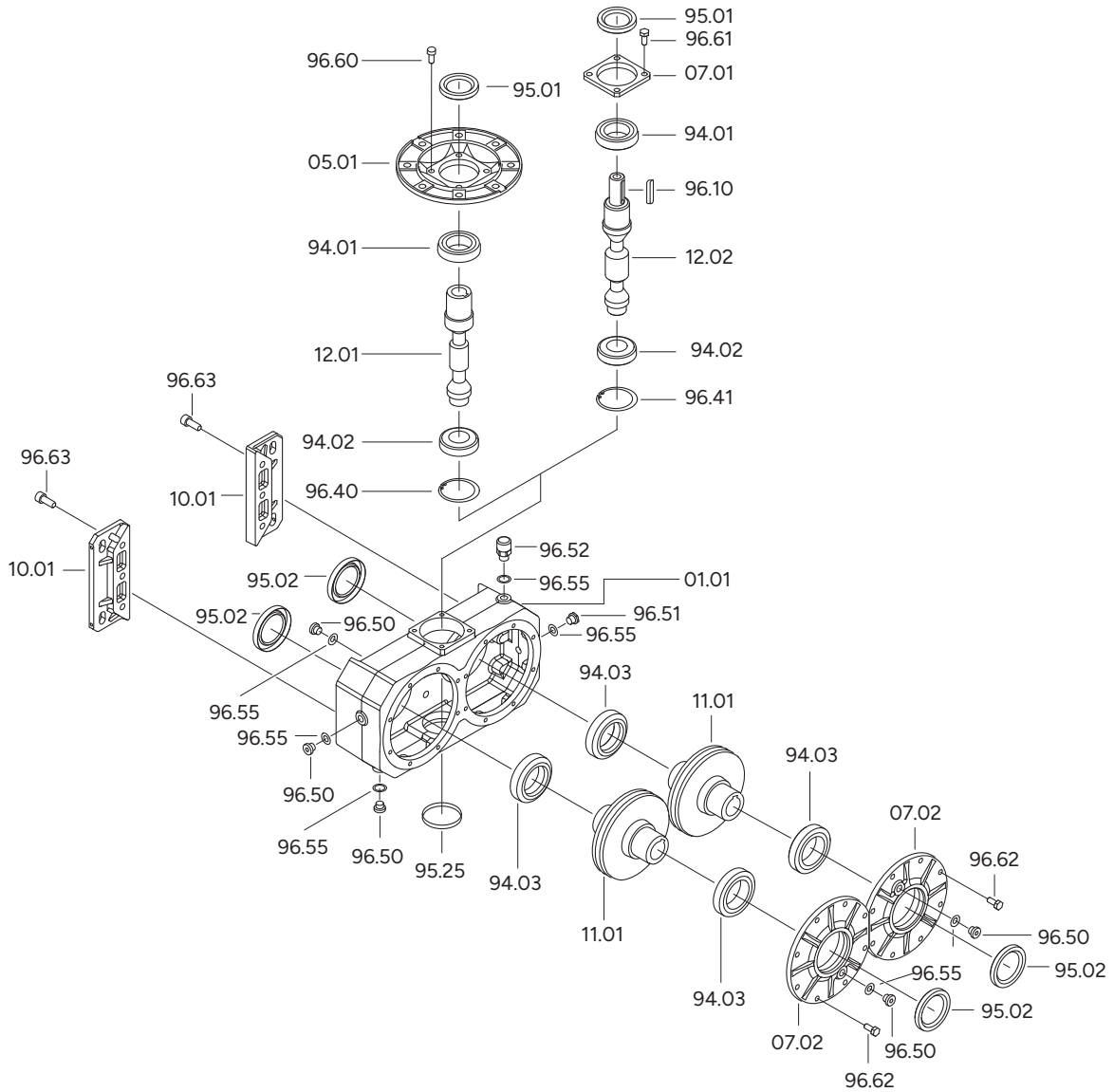

VM VI 170	Cuscinetti / Bearings / Lager			Anelli di tenuta / Oilseals Öldichtungen		Cappellotto / Closed oil seal Geschlossene Öldichtung
	94.01	94.02	94.03	95.01	95.02	95.25
	32008	30206	32010	40/62/8	50/72/8	ø 62x7
	40x68x19	30x62x17.25	50x80x20			

## VM 230

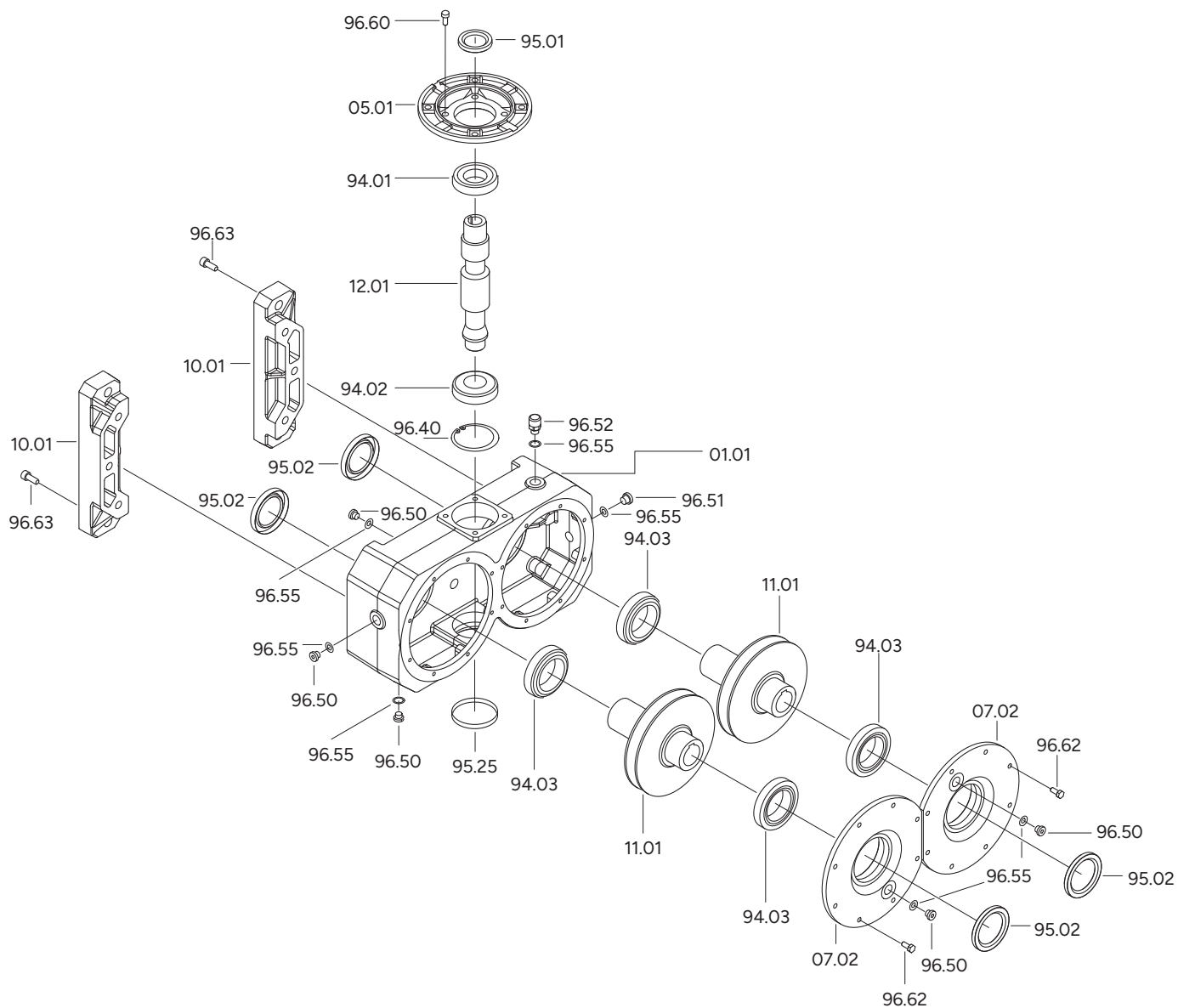

VM	Cuscinetti / Bearings / Lager			Anelli di tenuta / Oilseals Öldichtungen		Cappello / Closed oil seal Geschlossene Öldichtung
	94.01	94.02	94.03	95.01	95.02	95.25
230	30208	30307	32012	40/72/7	60/85/8	ø 80x10
	40x80x19.75	35x80x22.75	60x95x23			

## Targhetta

## Plate

## Schild

In fase di ordine delle parti di ricambio, specificare sempre n° particolare (vedi disegno esploso), data (1), n° codice (2) e n° variante (3). (Vedi targhetta).

When ordering please specify the spare part number (see exploded view) as well as the date (1), the article number (2) and the variant number (3). (see plate)

Bei der Bestellung von Ersatzteilen sind Ersatzteilnummer (s. Explosionszeichnung), Datum (1), Artikelnummer (2) und Variantennummer (3) anzugeben. (s. Schild)

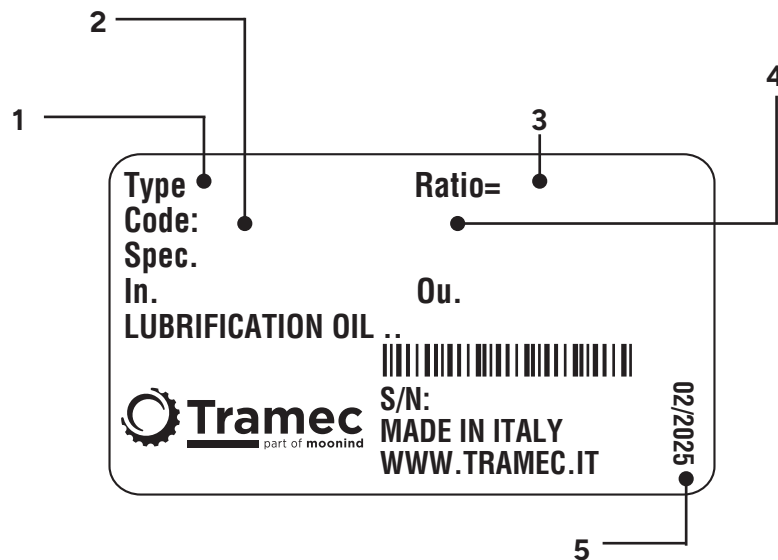

1	TIPO: descrizione	TYPE: description	TYP: Bezeichnung
2	CODICE: distinta base	CODE: base list	ART.-Nr.: Basisstückliste
3	RAP: rapporto di riduzione	RATIO: reduction ratio	ÜBERS: Untersetzungsverhältnis
4	VARIANTE: codice alfanumerico	MODEL: alphanumeric code	VARIANTE: alphanumerische Nummer
5	DATA: mese/anno	DATE: month/year	DATUM: Monat/Jahr



**VARIATORI N**
**VARIATORS N**
**VERSTELLGETRIEBE N**
**N**

Principio di funzionamento del variatore	<i>Variator operating principle</i>	Funktionsprinzip des Verstellgetriebes	<b>G2</b>
Variatori	<i>Variators</i>	Verstellgetriebe	<b>G3</b>
Caratteristiche	<i>Characteristics</i>	Merkmale	<b>G3</b>
Designazione	<i>Designation</i>	Bezeichnung	<b>G4</b>
Dati tecnici	<i>Technical data</i>	Technische Daten	<b>G6</b>
Lubrificazione	<i>Lubrication</i>	Schmierung	<b>G7</b>
Posizioni di montaggio	<i>Mounting positions</i>	Montageposition	<b>G8</b>
Dimensioni	<i>Dimensions</i>	Abmessungen	<b>G9</b>



## Principio di funzionamento del variatore

Si tratta di una trasmissione epicicloidale a rapporto variabile.

Quando il motore aziona il solare (5-6), i satelliti (8) sono indotti a ruotare sul proprio asse e, contemporaneamente, per effetto del vincolo con la pista esterna fissa (7) e la pista esterna mobile (9), ad un movimento di rivoluzione che trascina in rotazione il portasatelliti (albero uscita).

Variando la posizione assiale della pista esterna mobile (9) tramite la vite di comando, l'anello portasatelliti (14) e la camma fissa (15), i satelliti sono costretti a variare la loro posizione radiale di rivoluzione. In tal modo i diametri di rotolamento cambiano, così come la velocità angolare dell'albero uscita. Quando il contatto di rotolamento con le piste esterne (7) (9) si trova verso il centro del satellite (8), la velocità di rivoluzione è più bassa: l'albero uscita ruoterà più lentamente ma avrà disponibile un maggior momento torcente.

### Attenzione

La regolazione della velocità si può effettuare SOLO col variatore in funzione, MAI a macchina ferma.

## Variator operating principle

*The mechanical variator is based on an epicyclic transmission for variable ratios. The motor rotates the solar rings (5-6) which rotate the satellites (8). In turn these are in contact with the fixed outer ring (7) and external mobile ring (9).*

*The satellites rotate around their axes while simultaneously originate the rotation of the satellite carrier (output shaft).*

*When the rolling contact point of the outer rings (7) (9) is near the center of satellites (8) the output speed will reduce: the output shaft will rotate more slowly thus increasing the output torque value.*

### Warning

*Speed adjustment is only possible when variator is running, never adjust speed while variator is stationary. This will result in damage to the variator.*

## Funktionsprinzip des Verstellgetriebes

Das Verstellgetriebe ist ein Planetengetriebe mit verstellbarem Übersetzungsverhältnis. Der Motor treibt das Sonnenrad (5-6) an. Die Drehbewegung wird auf die Planetenräder (8) übertragen. Die Verbindung zwischen der unbeweglichen (7) und der beweglichen (9) äußeren Laufbahn überträgt die Drehbewegung an die Abtriebswelle.

Durch die Verschiebung des Kugelringes (14) und der Nocke (15) ändert sich die Axiallage der beweglichen Laufbahn (9) und die Radiallage der Planetenräder. Auf diese Weise ändern sich den Rollendurchmesser und die Winkelgeschwindigkeit der Abtriebswelle. Verschiebt sich der Kontaktpunkt zwischen den Planetenrädern (7) und der äußeren Laufbahn (9) gegen das Zentrum der Planetenräder, sinkt die Ausgangsdrehzahl und das Drehmoment steigt.

### Vorsicht

Die Geschwindigkeit darf nur verstellt werden, wenn das Verstellgetriebe im Betrieb ist und nicht wenn es still steht. Andernfalls kommt es zu einer Beschädigung des Verstellgetriebes.

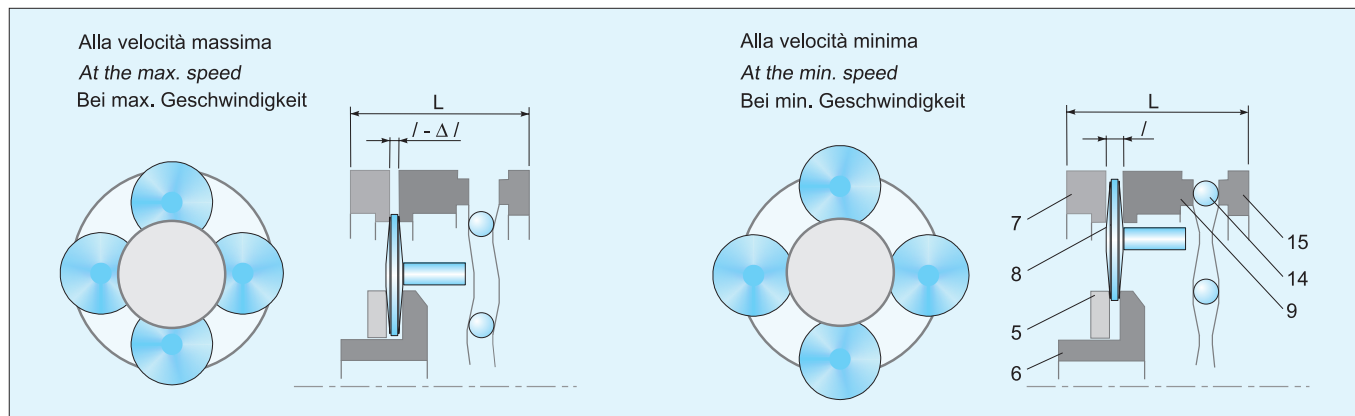

## Variatore

I variatori meccanici serie N sono in alluminio nelle grandezze 003, 005, 010, 020, 030, 050 per potenze da 0.18 kW a 4 kW.

## Variators

*The mechanical variators N Series size 003, 005, 010, 020, 030, and 050 power range 0.18 kW to 4kW are manufactured in aluminium.*

## Verstellgetriebe

Die mechanischen Verstellgetriebe Serie N in den Größen 003, 005, 010, 020, 030 und 050 für Leistungen von 0.18kW bis 4kW, sind aus Aluminium gefertigt.

## Caratteristiche

- La carcassa in alluminio, oltre ad una migliore estetica, comporta un minor peso del variatore rendendone più convenienti applicazioni e trasporti.
- Sul modulo base è possibile montare, in modo semplice e veloce, flangia uscita o piede, a seconda delle necessità. Questo riduce i volumi di stoccaggio ed i tempi di consegna.
- Il lato di entrata del variatore è chiuso, parte integrale col corpo: questo rende più facile l'installazione ed elimina totalmente la possibilità di perdite d'olio.
- È previsto, come standard, il collegamento a motori a dimensioni IEC forma B5.
- Il tappo di scarico olio è del tipo a magnete: la lubrificazione più pulita consente intervalli di manutenzione più lunghi.
- Funzionamento in bagno d'olio, silenzioso, con elevato rendimento ed esente da vibrazioni.
- Il funzionamento è possibile in entrambi i sensi di rotazione con entrata ed uscita concordi.
- Campo di variazione 1 - 6.
- L'albero di comando è bisporgente ed è quindi accessibile, per la manovra, da entrambe le estremità.

## Characteristics

- *The aluminium housing benefits weight reduction for more convenient applications and transportation.*
- *The simple design allows both foot or flange mounting to standard unit, reducing stocking levels and allowing quick delivery.*
- *The closed input flange is an integral part of the variator casing for easy installation and prevents possibility of oil leaks.*
- *IEC B5 motor connections available as standard.*
- *The magnetic breather plug maintains a clean lubricant and extends maintenance intervals.*
- *The oil bath operation provides high efficiency for noiseless and vibration free running.*
- *The unit can operate in both directions, input and output shafts rotate in the same direction.*
- *Range of variation 1 - 6.*
- *The double extended drive shaft allows easy installation from both sides.*

## Merkmale

- Dank dem Gehäuse aus Aluminium ist das Verstellgetriebe sehr leicht, was zur erleichterten Anwendung und Transport dient.
- Auf das Grundmodul können entweder Abtriebsflansch oder Fuß montiert werden. Das bringt Raumersparnis und schnellere Lieferzeit mit sich.
- Die Antriebsseite ist geschlossen und integrales Bestandteil des Gehäuses: Installation ist einfacher und Ölverluste sind ausgeschlossen.
- Standard-Anbau zu IEC B5 Motoren.
- Magnet-Ölablassschraube: die reinigere Schmierung erlaubt längere Wartungsintervalle.
- Betrieb im Ölbad ist geräuschlos, mit erhöhter Leistung und vibrationsfrei.
- Betrieb ist in beide Drehrichtungen möglich, mit Antriebs- und Abtriebswellen in derselber Richtung drehend.
- Verstellbereich 1 - 6.
- Die Welle für das Steuer-Handrad ist beidseitig herausgeführt, sodass es von beiden Seiten bedient werden kann.

**Designazione**
**Designation**
**Bezeichnung**

Tipo Type Typ	Grandezza Size Größe	Albero uscita diam. mm Output shaft diam. mm Abtriebswelle Durchmesser mm	Flangia uscita diam. mm Output flange diam. mm Abtriebsflansch Durchmesser mm	Attacco motore IEC IEC motor adaptor IEC Motoranbau	Posizione di montaggio Mounting position Einbaulage	Posizione scatola di comando Speed control box position Lage des Steuerkastens	Potenza motore Motor power Motorleistung	N° poli Poles number Polzahl	Forma costruttiva motore Motor version Motorversion	Tensione Voltage Spannung	Frequenza Frequency Frequenz	Posizione morsettiere Terminal box position Lage des Klemmkastens
<b>NF</b>	<b>030</b>	<b>AU28</b>	<b>F250</b>	<b>100B5</b>	<b>B5</b>	<b>SA</b>	<b>2.2 kW</b>	<b>4</b>	<b>B5</b>	<b>230/400</b>	<b>50Hz</b>	<b>MA</b>
<b>N</b> <b>NM</b> <b>NF</b>	<b>003</b> <b>005</b> <b>010</b> <b>020</b> <b>030</b> <b>050</b>	Vedi tabella	Vedi tabella	Vedi tabella	<b>B3</b> <b>B6</b> <b>B7</b> <b>B8</b> <b>V5</b> <b>V6</b> <b>B5</b> <b>V1</b> <b>V3</b>	<b>SA</b> <b>SB</b> <b>SC</b> <b>SD</b>	Vedi tabella	<b>2</b> <b>4</b> <b>6</b>	<b>B5</b>			<b>MA</b> <b>MB</b> <b>MC</b> <b>MD</b>
<b>NK</b> <b>NMK</b> <b>NFK</b>	<b>030</b> <b>050</b>	Siehe Tabelle	Siehe Tabelle	Siehe Tabelle			Siehe Tabelle					

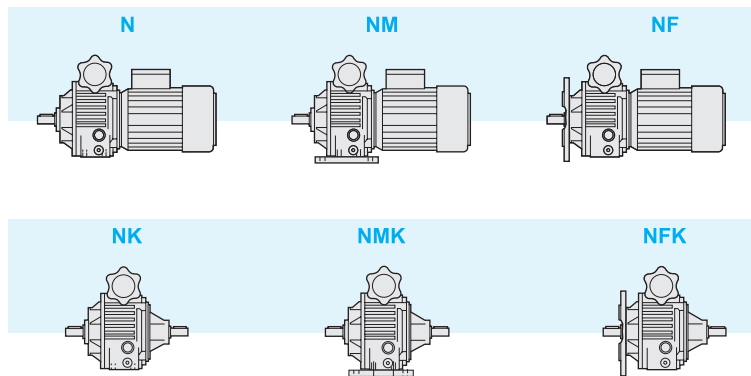
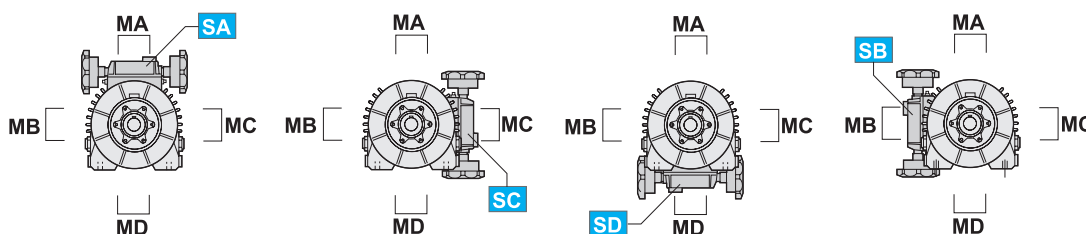

**Posizione morsettiere  
e scatola di comando**
**Terminal box and speed  
control box position**
**Lage des Klemmkastens und des  
Steuerkastens**

**MA, MB, MC, MD**  
 Posizione morsettiere  
 Terminal box position  
 Lage des Klemmkastens

**SA, SB, SC, SD**  
 Posizione scatola di comando  
 Speed control box position  
 Lage des Steuerkastens

**Designazione**
**Designation**
**Bezeichnung**

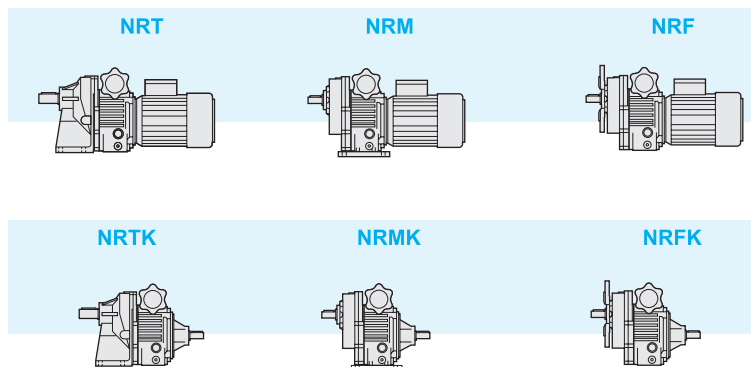
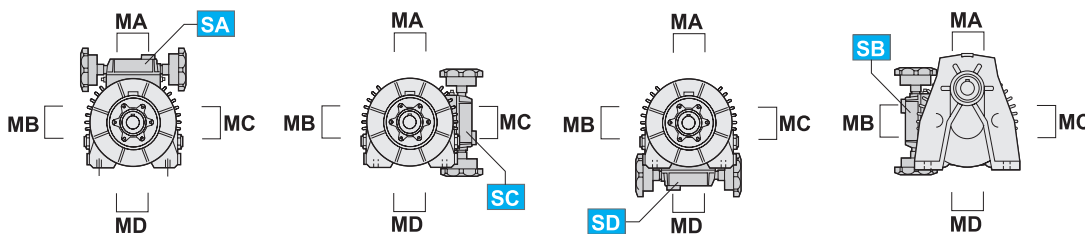
Tipo Type Typ	Grandezza Size Größe	Rapporto di riduzione (i) Reduction ratio (i) Untersetzungsverhältnis	Albero uscita diam. mm Output shaft diam. mm Abtriebswelle Durchmesser mm	Flangia uscita diam. mm Output flange diam. mm Abtriebsflansch Durchmesser mm	Attacco motore IEC IEC motor adaptor IEC Motoranbau	Posizione di montaggio Mounting position Einbaulage	Posizione scatola di comando Speed control box position Lage des Steuerkastens	Potenza motore Motor power Motorleistung	N° poli Poles number Polzahl	Forma costruttiva motore Motor version Motorversion	Tensione Voltage Spannung	Frequenza Frequency Frequenz	Posizione morsettiera Terminal box position Lage des Klemmkastens
<b>NRF</b>	<b>003/1</b>	<b>5</b>	<b>AU19</b>	<b>F160</b>	<b>63B5</b>	<b>B5</b>	<b>SA</b>	<b>0.25 kW</b>	<b>4</b>	<b>B5</b>	<b>230/400 50Hz</b>	<b>MA</b>	
<b>NRT</b> <b>NRM</b> <b>NRF</b> <b>NRTK</b> <b>NRMK</b> <b>NRFK</b>	<b>003/1</b> <b>005/1</b> <b>010/1</b> <b>020/1</b> <b>030/1</b> <b>050/1</b>	<b>2.5</b> <b>5</b>	Vedi tabella  See tables  Siehe Tabelle	Vedi tabella  See tables  Siehe Tabelle	Vedi tabella  See tables  Siehe Tabelle	<b>B3</b> <b>B6</b> <b>B7</b> <b>B8</b> <b>V5</b> <b>V6</b> <b>B5</b> <b>V1</b> <b>V3</b>	<b>SA</b> <b>SB</b> <b>SC</b> <b>SD</b>	Vedi tabella  See tables  Siehe Tabelle	<b>2</b> <b>4</b> <b>6</b>	<b>B5</b>			<b>MA</b> <b>MB</b> <b>MC</b> <b>MD</b>

**Posizione morsettiera  
e scatola di comando**
**Terminal box and speed  
control box position**
**Lage des Klemmkastens und des  
Steuerkastens**

**MA, MB, MC, MD**  
Posizione morsettiera  
Terminal box position  
Lage des Klemmkastens

**SA, SB, SC, SD**  
Posizione scatola di comando  
Speed control box position  
Lage des Steuerkastens

**Dati tecnici**
**Technical data**
**Technische Daten**

Tipo Type Typ	P <sub>1</sub> kW	Poli Poles Polen	Attacco motore IEC IEC motor adaptor IEC Motoranbau	n <sub>2</sub> max rpm	n <sub>2</sub> min rpm	i	T <sub>2</sub> min Nm	T <sub>2</sub> max Nm
N003	0.25	4	63 B5	950	190	—	1.9	3.8
	0.37	2	63 B5	1900	380	—	1.5	3
NR 003/1	0.25	4	63 B5	380	76	2.5	4.7	9.3
				190	38	5	9.3	18.6
N005	0.37	4	71 B5	1000	167	—	3	6
	0.55	4	71 B5	1000	167	—	4.5	9
	0.75	2	71 B5	2000	333	—	3	6
NR 005/1	0.37	4	71 B5	400	67	2.5	7.3	14.7
				200	33	5	14.7	29.4
N010	0.75	4	80 B5	1000	167	—	6	12
	0.92	4	80 B5	1000	167	—	7.5	12
	1.5	2	80 B5	2000	333	—	6	12
NR 010/1	0.75	4	80 B5	400	67	2.5	14.7	29.4
				200	33	5	29.4	58.8
N020	1.5	4	90 B5	1000	167	—	12	24
	1.85	4	90 B5	1000	167	—	15	24
	2.2	2	90 B5	2000	333	—	9	18
NR 020/1	1.5	4	90 B5	400	67	2.5	29.4	58.8
				200	33	5	58.8	118
N030	2.2	6	100 B5	660	125	—	27	54
	2.2	4	100 B5	1000	167	—	18	36
	3	4	100 B5	1000	167	—	24	48
NR 030/1	2.2	4	100 B5	400	67	2.5	44.1	88.2
				200	33	5	88.2	176
N050	4	4	112 B5	1000	167	—	32	64
NR 050/1	4	4	112 B5	400	67	2.5	78.4	157
				200	33	5	157	314

Simbologia:

**P<sub>1</sub>** [kW] Potenza motore  
**poli** N° poli motore  
**n<sub>2</sub> max** [rpm] Velocità massima in uscita  
**n<sub>2</sub> min** [rpm] Velocità minima in uscita  
**T<sub>2</sub> min** [Nm] Coppia alla velocità massima  
**T<sub>2</sub> max** [Nm] Coppia alla velocità minima  
**i** Rapporto di riduzione

Symbols:

**P<sub>1</sub>** [kW] Motor power  
**poles** Number of poles  
**n<sub>2</sub> max** [rpm] Max output speed  
**n<sub>2</sub> min** [rpm] Min output speed  
**T<sub>2</sub> min** [Nm] Output torque at the high speed  
**T<sub>2</sub> max** [Nm] Output torque at the low speed  
**i** Reduction ratio

Symbole:

**P<sub>1</sub>** [kW] Motorleistung  
**poli** Motor Polzahl  
**n<sub>2</sub> max** [rpm] Max Abtriebsdrehzahl  
**n<sub>2</sub> min** [rpm] Min. Abtriebsdrehzahl  
**T<sub>2</sub> min** [Nm] Drehmoment bei max. Drehzahl  
**T<sub>2</sub> max** [Nm] Drehmoment bei min. Drehzahl  
**i** Untersetzungsverhältnis

Il diagramma A riporta i valori indicativi del rendimento del variatore alle varie velocità in uscita n<sub>2</sub> espresse in rpm e il diagramma B indica la percentuale di carico sul motore.

Diagramm A shows the indicative value of efficiency in relation to output speed n<sub>2</sub> expressed in rpm. Diagram B shows the percentage of motor output power utilized.

Diagramm A zeigt die Richtwerte des Wirkungsgrads in Abhängigkeit zur n<sub>2</sub> in rpm. Diagramm B zeigt den Prozentsatz der abgegebenen Motorleistung.

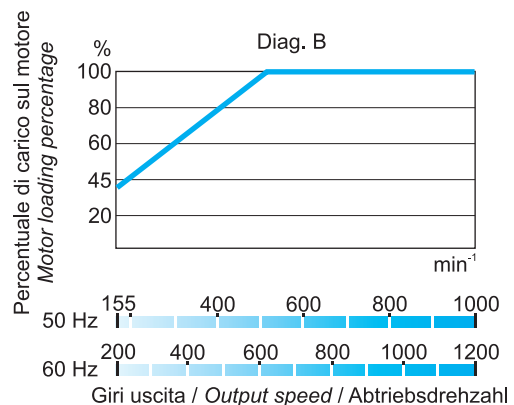
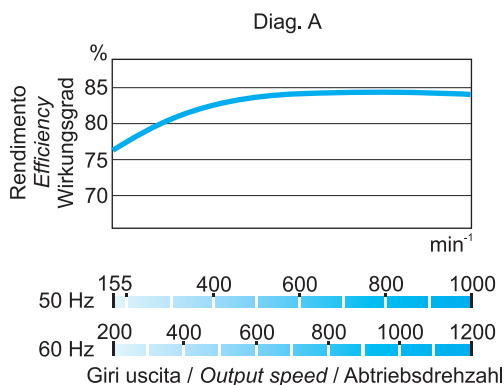

I diagrammi seguenti riportano le curve di coppia riferite alle varie potenze applicate e al numero di giri in entrata al variatore  $n_1$  (rpm).

The following diagrams show the performance for output torque in relation to input power and input speed  $n_1$  (rpm).

Die folgenden Diagramme zeigen die Drehmomentkurven bezüglich Leistung und Antriebsdrehzahl.

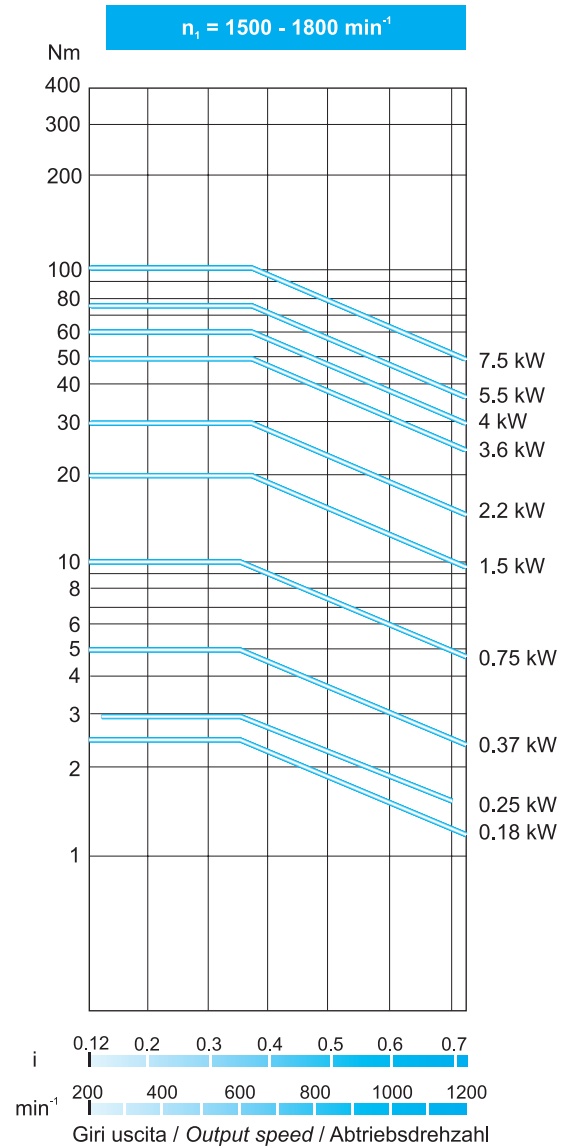
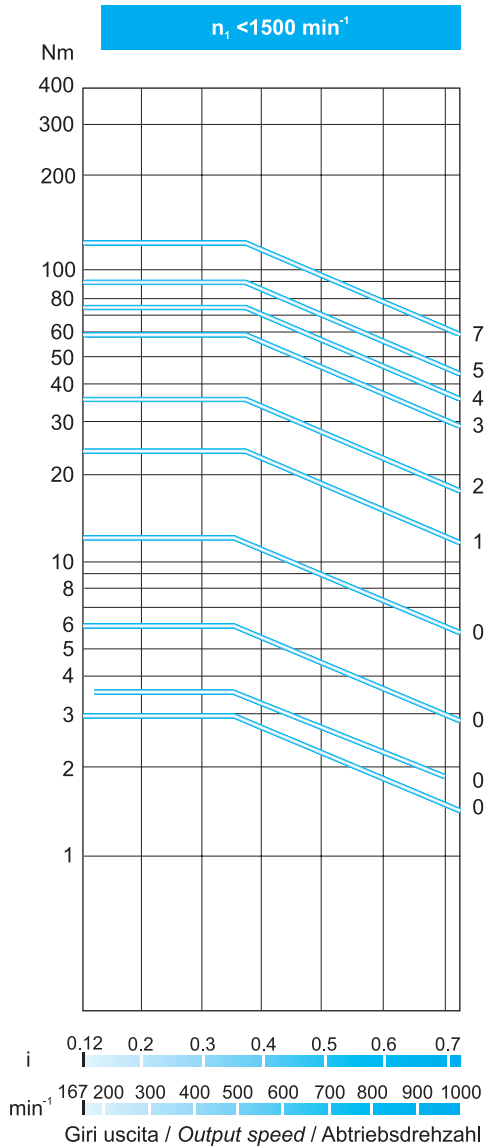

### Lubrificazione

I variatori vengono forniti completi di lubrificante. Dopo il piazzamento del variatore assicurarsi che il livello del lubrificante sia visibile dall'apposita spia di livello effettuando eventuali rabbocchi se necessario, con un analogo lubrificante scelto fra quelli raccomandati in tabella.

### Lubrication

The variators are supplied complete with lubricant. After the mounting pls make sure the oil can be seen through the oil level plug this to allow the filling up if necessary. Oil has to be selected among the recommended ones.

### Schmierung

Die Verstellgetriebe werden mit Schmiermittel geliefert. Nach Einbau des Verstellgetriebes ist der Ölstand durch das Schauglas zu prüfen. Wenn nötig, füllen Sie mit einem der empfohlenen Öle auf (siehe Tabelle).

Tipi di lubrificanti raccomandati / Recommended lubricants / Empfohlene Öle			
Dexron fluid II	<b>IP</b>		Atina grease O
A.T.F. Dexron fluid DIII	<b>SHELL</b>		
A.T.F. 200 RED	<b>MOBIL</b>		
A.T.F. Dexron	<b>FINA</b>		
BP Autran DX	<b>BP</b>		Tivela Compound A
A.T.F. Dexron	<b>ESSO</b>		
A.T.F. Dexron	<b>CHEVRON</b>		
A.T.F. Dexron	<b>AGIP</b>		

**Posizioni di montaggio**

**Mounting positions**

**Montageposition**

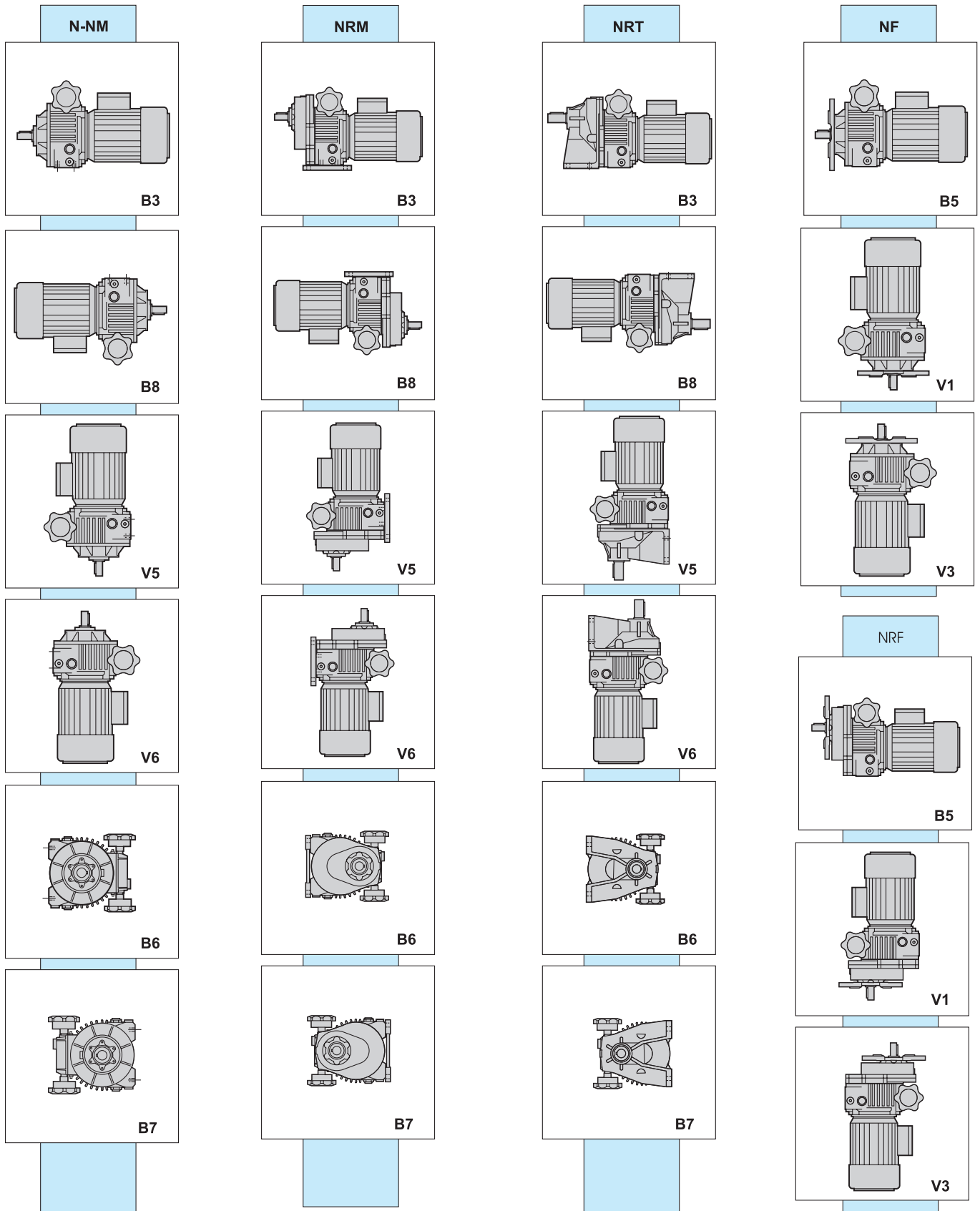

**Dimensioni**

**Dimensions**

**Abmessungen**

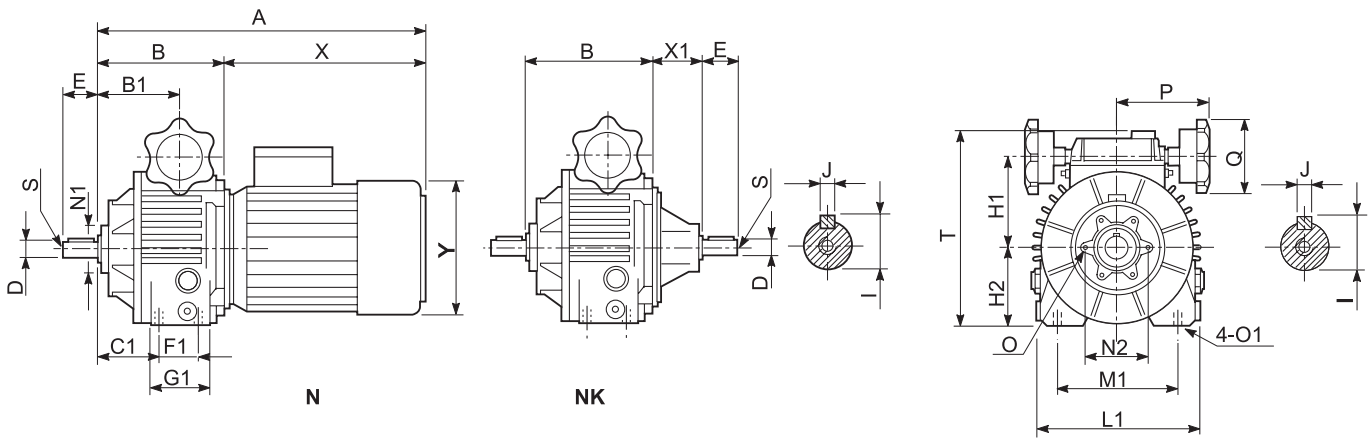

Tipo Type Typ	A	B	B1	C1	D	E	F1	G1	H1	H2	I	J	L1	M1	N1	N2	O	O1	P	Q	S	T	X	X1	Y	Kg
<b>N003</b>	302	110	66	44	11	23	36	55	79	58	12.5	4	128	100	42	56	M6	M8	97	89	M5	160	192	42	122	5
<b>N005</b>	336	118	78	61	14	30	36	55	88	73	16	5	153	120	56	75	M6	M8	97	89	M6	185	218	50	137	7
<b>N010</b>	383	145	95	75	19	40	45	82	107	91	21.5	6	187	140	56	75	M6	M10	107	89	M6	222	239	65	158	13
<b>N020</b>	450	172	105	82	24	50	58	82	126	108	27	8	220	190	75	100	M8	M10	107	89	M8	264	278	70	177	20

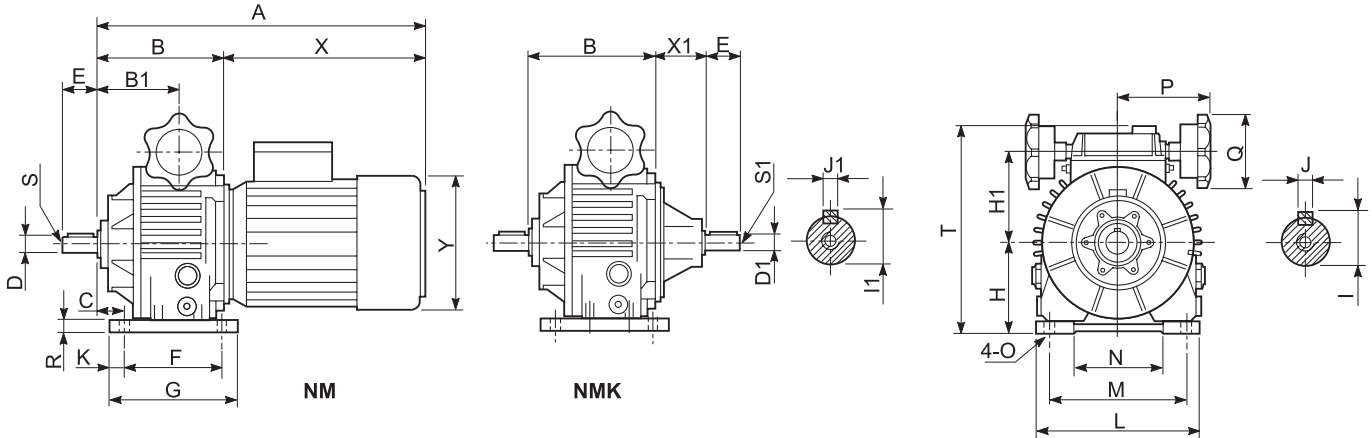

Tipo Type Typ	A	B	B1	C	D	D1	E	F	G	H	H1	I	I1	J	J1	K	L	M	N	O	P	Q	R	S	S1	T	X	X1	Y	Kg
<b>NM003</b>	302	110	66	25	11 (14)	11	23 (30)	105	130	71	76	12.5 (16)	12.5	4 (5)	4	12.5	140	110	80	9	97	89	11	M5 (M6)	M5	173	192	42	122	6
<b>NM005</b>	336	118	78	30	14 (19)	14	30 (40)	105	130	90	88	16 (21.5)	16	5 (6)	5	12.5	155	120	83	10	97	89	13	M6	M6	202	218	50	137	8
<b>NM010</b>	382	143	95	35	19 (24)	19	40 (50)	125	150	106	107	21.5 (27)	21.5	6 (8)	6	12.5	190	160	120	12	107	89	13.5	M6 (M8)	M6	242	239	65	158	14
<b>NM020</b>	441	171	104	50	24 (28)	24	50 (60)	140	165	125	126	27 (31)	27	8	8	12.5	230	180	130	12	107	89	16	M8 (M10)	M8	277	270	70	177	21
<b>NM030/050</b>	546	206	122	25	28 (38)	28	60 (80)	230	270	150	158	31 (41)	31	8 (10)	8	20	300	245	190	14	155	120	20	M10 (M12)	M10	337	340	95	197	51

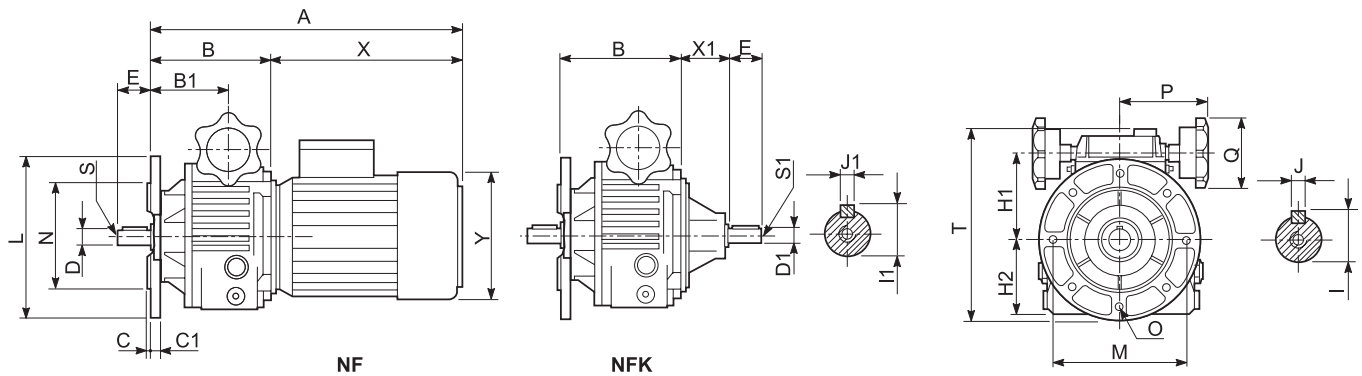
**Dimensioni**
**Dimensions**
**Abmessungen**

Tipo Type Typ	A	B	B1	C	C1	D	D1	E	H1	H2	I	I1	J	J1	L	M	N	O	P	Q	S	S1	T	X	X1	Y	Kg
<b>NF003</b>	302	110	66	3.5	8	11 (14)	11	23 (28)	76	58	12.5 (16)	12.5	4 (5)	4	140 (160)	115 (130)	95 (110)	9 (9)	97	89	M5	M5	165 (175)	192	42	122	6
<b>NF005</b>	338	120	80	3.5	10.5	14 (19)	14	28 (38)	88	73	16 (21.5)	16	5 (6)	5	160 (200)	130 (165)	110 (130)	9 (11)	97	89	M6	M6	188 (208)	218	50	137	8
<b>NF010</b>	384	145	97	3.5	13.5	19 (24)	19	38 (48)	107	91	21.5 (27)	21.5	6 (8)	6	200	165	130	11	107	89	M6 (M8)	M6	237	239	65	158	14
<b>NF020</b>	443	173	106	4	14	24 (28)	24	48 (58)	126	108	27 (31)	27	8	8	200 (250)	165 (215)	130 (180)	11 (14)	107	89	M8 (M10)	M8	260 (277)	270	70	177	21
<b>NF030/050</b>	548	208	124	4(5)	16	28 (38)	28	58 (78)	158	134	31 (41)	31	8 (10)	8	250 (300)	215 (265)	180 (230)	14	155	120	M10 (M12)	M10	336	340	95	197	51

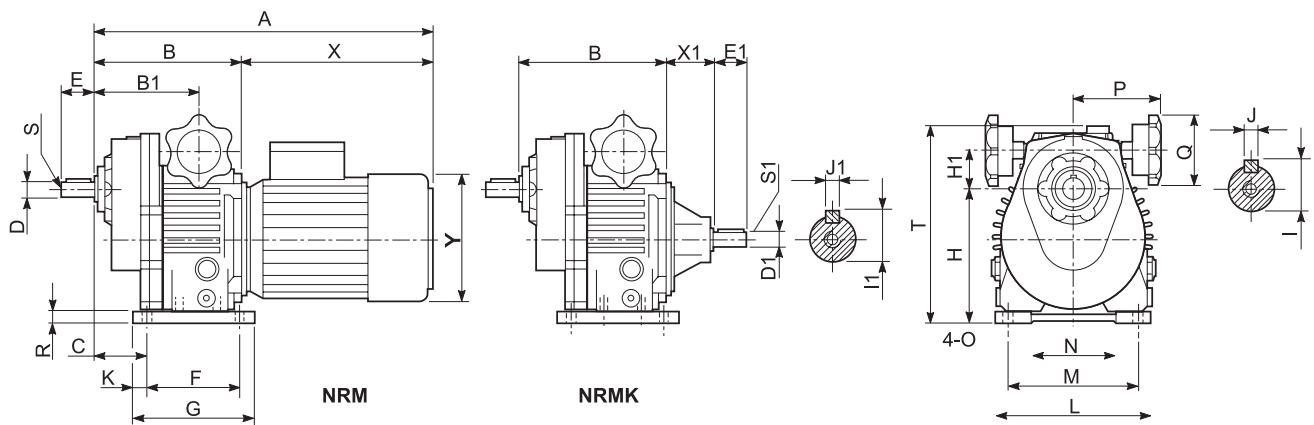

Tipo Type Typ	A	B	B1	C	D	D1	E	E1	F	G	H	H1	I	I1	J	J1	K	L	M	N	O	P	Q	R	S	S1	T	X	X1	Y	Kg
<b>NRM003</b>	331	139	108	57	19 (20)	11	30	23	105	130	111 (116)	36	21.5 (22.5)	12.5	6	4	12.5	140	110	80	9	97	89	11	M6	M5	173	192	42	122	7
<b>NRM005</b>	363	145	105	54	19 (20)	14	30	30	105	130	140 (135)	38	21.5 (22.5)	16	6	5	12.5	155	120	83	10	97	89	13	M6	M6	202	218	50	137	11
<b>NRM010</b>	418	179	131	69	24 (25)	19	35	40	125	150	169 (160)	44	27 (28)	21.5	8	6	12.5	190	160	120	12	107	89	13.5	M8	M6	242	239	65	158	9
<b>NRM020</b>	471	201	135	78	28 (30)	24	45	50	140	165	188 (190)	63	31 (33)	27	8	8	12.5	230	180	130	12	107	89	16	M10	M8	277	270	70	177	33
<b>NRM030</b> <b>NRM050</b>	586	246	165	63	38 (40)	28	60	60	230	270	230 (224)	78	41 (43)	31	10 (12)	8	20	300	245	190	14	155	120	20	M12	M8	337	340	95	197	75

**Dimensioni**

**Dimensions**

**Abmessungen**

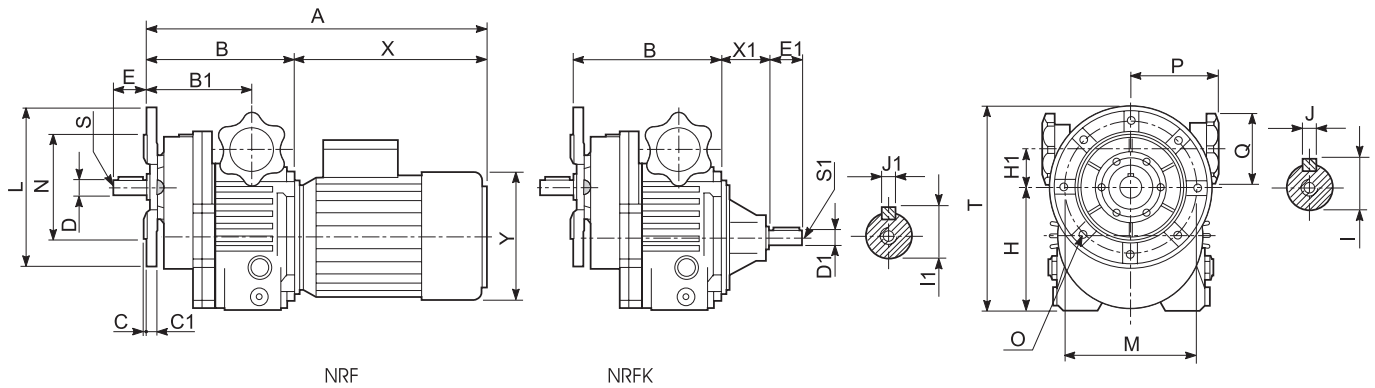

Tipo Type Typ	A	B	B1	C	C1	D	D1	E	E1	H	H1	I	I1	J	J1	L	M	N	O	P	Q	S	S1	T	X	X1	Y	Kg
<b>NRF003</b>	333	141	112	3.5	8	19	11	28	23	98	36	21.5	12.5	6	4	160	130	110	9	97	89	M6	M5	178	192	42	122	7
<b>NRF005</b>	372	154	114	3.5	10.5	19	14	28	30	123	38	21.5	16	6	5	160	130	110	9	97	89	M6	M6	203	218	50	137	11
<b>NRF010</b>	419	180	130	3.5	13.5	24	19	33	40	154	44	27	21.5	8	6	200	165	130	11	107	89	M8	M6	254	239	65	158	19
<b>NRF020</b>	473	203	137	4	14	28	24	43	50	171	63	31	27	8	8	250	215	180	14	107	89	M10	M8	296	270	70	177	33
<b>NRF030/050</b>	588	248	167	4	16	38	28	58	60	214	78	41	31	10	8	300	265	230	14	155	120	M12	M8	364	340	95	197	75

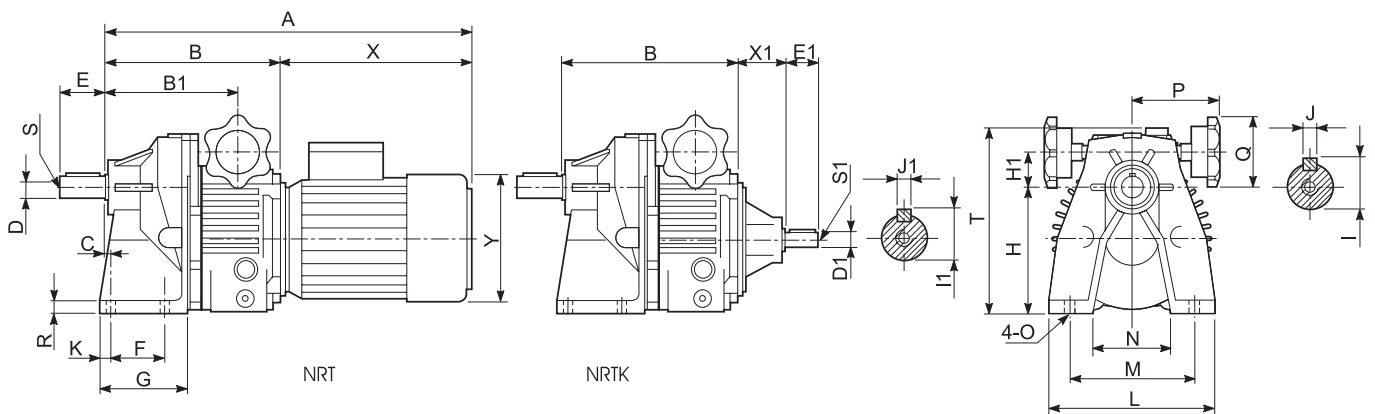

Tipo Type Typ	A	B	B1	C	D	D1	E	E1	F	G	H	H1	I	I1	J	J1	K	L	M	N	O	P	Q	R	S	S1	T	X	X1	Y	Kg
<b>NRT003</b>	<b>376</b>	184	140	20	19	11	40	23	45	80	110	36	21.5	12.5	6	4	14	130	105	70	9	97	89	10	M6	M5	167	192	42	122	9
<b>NRT005</b>	<b>412</b>	194	154	6	24	14	50	30	70	110	130	38	27	16	8	5	15	180	150	90	11	97	89	12	M8	M6	192	218	50	137	13
<b>NRT010</b>	<b>456</b>	218	171	7.5	28	19	60	40	70	115	163	44	31	21.5	8	6	14	215	165	100	11	107	89	15	M8	M6	231	239	65	158	21
<b>NRT020</b>	<b>551</b>	281	215	25	38	24	70	50	85	142	195	46	41	27	10	8	23	250	185	130	14	107	120	16	M10	M8	266	270	70	177	33
<b>NRT030/050</b>	<b>686</b>	346	261	19	48	28	100	60	130	178	250	59	51.5	31	14	8	17	310	240	160	17	155	120	18	M10	M8	337	340	95	197	75



**VARIATORI UDL**
**VARIATORS UDL**
**VERSTELLGETRIEBE UDL**
**UDL**

Principio di funzionamento del variatore	<i>Variator operating principle</i>	Funktionsprinzip des Verstellgetriebes	<b>H2</b>
Variatori	<i>Variators</i>	Verstellgetriebe	<b>H3</b>
Caratteristiche	<i>Characteristics</i>	Merkmale	<b>H3</b>
Designazione	<i>Designation</i>	Bezeichnung	<b>H4</b>
Dati tecnici	<i>Technical data</i>	Technische Daten	<b>H6</b>
Lubrificazione	<i>Lubrication</i>	Schmierung	<b>H7</b>
Posizioni di montaggio	<i>Mounting positions</i>	Montageposition	<b>H8</b>
Dimensioni	<i>Dimensions</i>	Abmessungen	<b>H9</b>



## Principio di funzionamento del variatore

Si tratta di una trasmissione epicicloidale a rapporto variabile.

Quando il motore aziona il solare (5-6), i satelliti (8) sono indotti a ruotare sul proprio asse e, contemporaneamente, per effetto del vincolo con la pista esterna fissa (7) e la pista esterna mobile (9), ad un movimento di rivoluzione che trascina in rotazione il portasatelliti (albero uscita).

Variando la posizione assiale della pista esterna mobile (9) tramite la vite di comando, l'anello portasfere (14) e la camma fissa (15), i satelliti sono costretti a variare la loro posizione radiale di rivoluzione. In tal modo i diametri di rotolamento cambiano, così come la velocità angolare dell'albero uscita.

Quando il contatto di rotolamento con le piste esterne (7) (9) si trova verso il centro del satellite (8), la velocità di rivoluzione è più bassa: l'albero uscita ruoterà più lentamente ma avrà disponibile un maggior momento torcente.

### Attenzione

La regolazione della velocità si può effettuare SOLO col variatore in funzione, MAI a macchina ferma.

## Variator operating principle

*The mechanical variator is based on an epicyclic transmission for variable ratios. The motor rotates the solar rings (5-6) which rotate the satellites (8). In turn these are in contact with the fixed outer ring (7) and external mobile ring (9). The satellites rotate around their axes while simultaneously originate the rotation of the satellite carrier (output shaft).*

*When the rolling contact point of the outer rings (7) (9) is near the center of satellites (8) the output speed will reduce: the output shaft will rotate more slowly thus increasing the output torque value.*

### Warning

*Speed adjustment is only possible when variator is running, never adjust speed while variator is stationary. This will result in damage to the variator.*

## Funktionsprinzip des Verstellgetriebes

Das Verstellgetriebe ist ein Planetengetriebe mit verstellbarem Übersetzungsverhältnis. Der Motor treibt das Sonnenrad (5-6) an. Die Drehbewegung wird auf die Planetenräder (8) übertragen. Die Verbindung zwischen der unbeweglichen (7) und der beweglichen (9) äußeren Laufbahn überträgt die Drehbewegung an die Abtriebswelle.

Durch die Verschiebung des Kugelringes (14) und der Nocke (15) ändert sich die Axiallage der beweglichen Laufbahn (9) und die Radiallage der Planetenräder. Auf diese Weise ändern sich den Rollendurchmesser und die Winkelgeschwindigkeit der Abtriebswelle. Verschiebt sich der Kontaktpunkt zwischen den Planetenrädern (7) und der äußeren Laufbahn (9) gegen das Zentrum der Planetenräder, sinkt die Ausgangsdrehzahl und das Drehmoment steigt.

### Vorsicht

Die Geschwindigkeit darf nur verstellt werden, wenn das Verstellgetriebe im Betrieb ist und nicht wenn es still steht. Andernfalls kommt es zu einer Beschädigung des Verstellgetriebes.

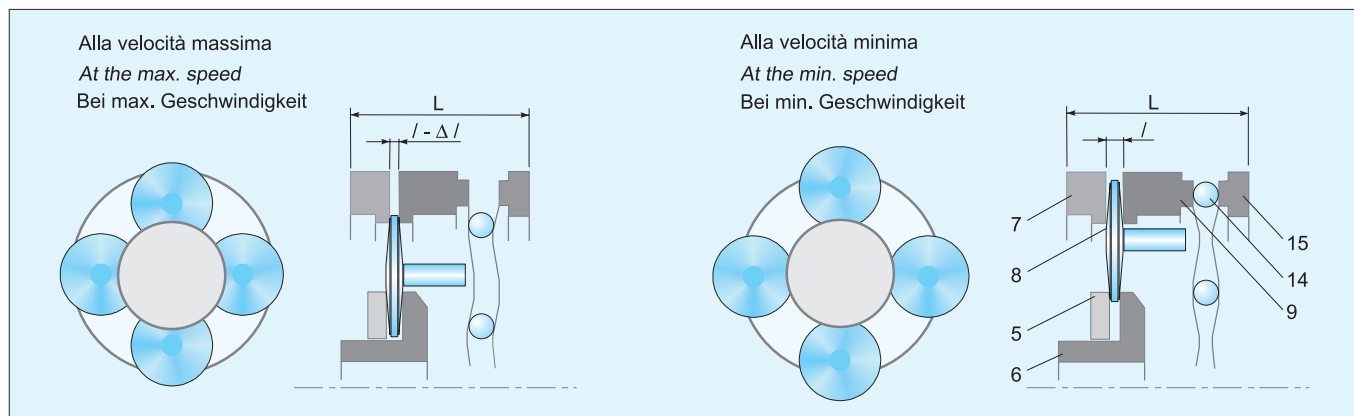

## Variatore

La gamma dei variatori di velocità TRAMEC si completa con la nuova serie UDL, grandezze disponibili 002, 005 e 010.

## Variators

*The present range of Tramec speed reducers has been completed by the new UDL Series available in 3 sizes: 002,005 and 010*

## Verstellgetriebe

Die aktuelle Tramec Variatoren - Serie wird ergänzt durch die neue UDL Serie. Sie ist in den Größen 002, 005 und 010 erhältlich.

## Caratteristiche

- La carcassa in alluminio, oltre ad una migliore estetica, comporta un minor peso del variatore rendendone più convenienti applicazioni e trasporti.
- Sul modulo base è possibile montare, in modo semplice e veloce, flangia uscita o piede, a seconda delle necessità. Questo riduce i volumi di stoccaggio ed i tempi di consegna.
- Il lato di entrata del variatore è chiuso, parte integrale col corpo: questo rende più facile l'installazione ed elimina totalmente la possibilità di perdite d'olio.
- È previsto, come standard, il collegamento a motori a dimensioni IEC forma B5.
- Il tappo di scarico olio è del tipo a magnete: la lubrificazione più pulita consente intervalli di manutenzione più lunghi.
- Funzionamento in bagno d'olio, silenzioso, con elevato rendimento ed esente da vibrazioni.
- Il funzionamento è possibile in entrambi i sensi di rotazione con entrata ed uscita concordi.

## Characteristics

- *The aluminium housing benefits weight reduction for more convenient applications and transportation.*
- *The simple design allows both foot or flange mounting to standard unit, reducing stocking levels and allowing quick delivery.*
- *The closed input flange is an integral part of the variator casing for easy installation and prevents possibility of oil leaks.*
- *IEC B5 motor connections available as standard.*
- *The magnetic breather plug maintains a clean lubricant and extends maintenance intervals.*
- *The oil bath operation provides high efficiency for noiseless and vibration free running.*
- *The unit can operate in both directions, input and output shafts rotate in the same direction.*

## Merkmale

- Dank dem Gehäuse aus Aluminium ist das Verstellgetriebe sehr leicht, was zur erleichterten Anwendung und Transport dient.
- Auf das Grundmodul können entweder Abtriebsflansch oder Fuß montiert werden. Das bringt Rausersparnis und schnellere Lieferzeit mit sich.
- Die Antriebsseite ist geschlossen und integrales Bestandteil des Gehäuses: Installation ist einfacher und Ölverluste sind ausgeschlossen.
- Standard-Anbau zu IEC B5 Motoren.
- Magnet-Ölablassschraube: die reinigere Schmierung erlaubt längere Wartungsintervalle.
- Betrieb im Ölbad ist geräuschlos, mit erhöhter Leistung und vibrationsfrei.
- Betrieb ist in beide Drehrichtungen möglich, mit Antriebs- und Abtriebswellen in derselben Richtung drehend.

Designazione	Designation						Bezeichnung				
Tipo Type Typ	Grandezza Size Größe	Albero uscita diam. mm Output shaft diam. mm Abtriebswelle Durchmesser mm	Flangia uscita diam. mm Output flange diam. mm Abtriebsflansch Durchmesser mm	Attacco motore IEC IEC motor adaptor IEC Motoranbau	Posizione di montaggio Mounting position Einbaulage	Potenza motore Motor power Motorleistung	N° poli Poles number Polzahl	Forma costruttiva motore Motor version Motorversion	Tensione Voltage Spannung	Frequenza Frequency Frequenz	
UDL	010	AU19	F200	80B5	B5	0.75 kW	4	B5	230/400	50Hz	
UDL	002 005 010	AU 11 AU 14 AU 19	F 140 F 160 F 200	63 B5 71 B5 80 B5	B5 V1 V3	0.18 0.25 0.37 0.55 0.75	4	B5	230/400	50Hz	

Dati tecnici	Technical data				Technische Daten			
Tipo Type Typ	P <sub>1</sub> kW	Poli Poles Polen	Attacco motore IEC IEC motor adaptor IEC Motoranbau	n <sub>2</sub> max rpm	n <sub>2</sub> min rpm	T <sub>2</sub> min Nm	T <sub>2</sub> max Nm	
UDL 002	0.18	4	63 B5	880	170	1.5	3	
UDL 005	0.25	4	71 B5	1000	200	2	6	
	0.37			1000	200	3	6	
UDL 010	0.55	4	80 B5	1000	200	4.4	12	
	0.75	4		1000	200	6	12	

Lubrificazione	Lubrication	Schmierung
I variatori vengono forniti completi di lubrificante. Dopo il piazzamento del variatore assicurarsi che il livello del lubrificante sia visibile dall'apposita spia di livello effettuando eventuali rabbocchi se necessario, con un analogo lubrificante scelto fra quelli raccomandati in tabella.	<i>The variators are supplied complete with lubricant. After the mounting pls make sure the oil can be seen through the oil level plug this to allow the filling up if necessary. Oil has to be selected among the recommended ones.</i>	Die Verstellgetriebe werden mit Schmiermittel geliefert. Nach Einbau des Verstellgetriebes ist der Ölstand durch das Schauglas zu prüfen. Wenn nötig, füllen Sie mit einem der empfohlenen Öle auf (siehe Tabelle).

Tipi di lubrificanti raccomandati / Recommended lubricants / Empfohlene Öle	
Dexron fluid II	IP
A.T.F. Dexron fluid DIII	SHELL
A.T.F. 200 RED	MOBIL
A.T.F. Dexron	FINA
BP Autran DX	BP
A.T.F. Dexron	ESSO
A.T.F. Dexron	CHEVRON
A.T.F. Dexron	AGIP

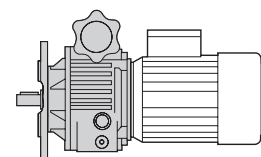

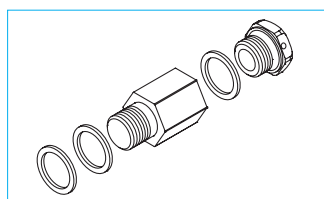
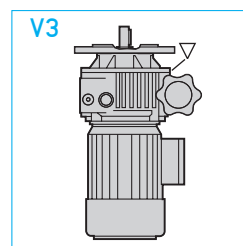
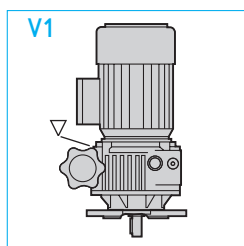
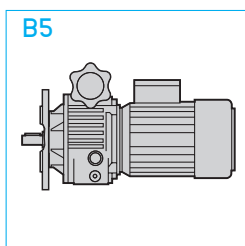
**Posizioni di montaggio**
**Mounting positions**
**Montageposition**

- ▽ Kit Tappo di sfianto solo per posizione di montaggio V1, V3
- ▽ Kit breather plug only for mounting positions V1, V3
- ▽ Kit Entlüftungsschraube Nur für die Einbaulagen V1, V3

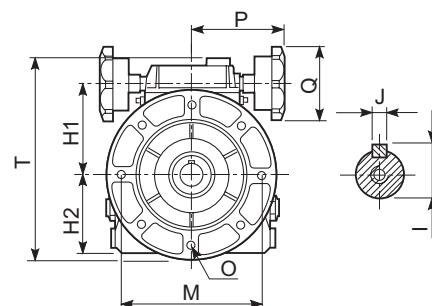
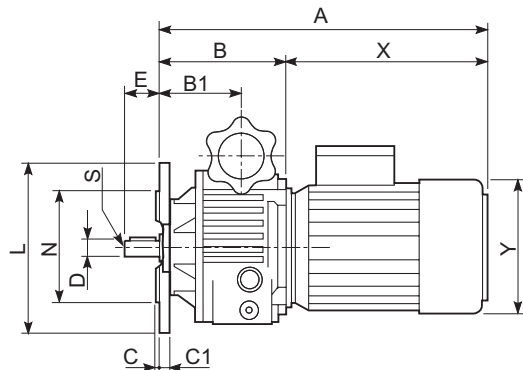
**Dimensioni**
**Dimensions**
**Abmessungen**

Tipo Type Typ	A	B	B1	C	C1	D	H1	H2	I	J	L	M	N	O	P	Q	S	T	X	Y	Kg
<b>UDL 002</b>	318.5	111.5	64	3.5	6.5	11	78	70	12.5	4	140	115	95	9	113	70	M5	183	207	130	3.3
<b>UDL 005</b>	333	108	71.5	3.5	8.5	14	91	80	16	5	160	130	110	9	113	70	M5	205	225	145	4.6
<b>UDL 010</b>	398.5	143.5	87.5	3.5	10.5	19	107	100	21.5	6	200	165	130	11	120	85	M6	242	255	175	7.9

I valori A, X e Y dipendono dal motore utilizzato

The values A, X and Y depend on the electric motor used.

Die Werte A, X und Y auf den Elektromotor abhängen



MOTORI ELETTRICI

ELECTRIC MOTORS

ELEKTROMOTOREN

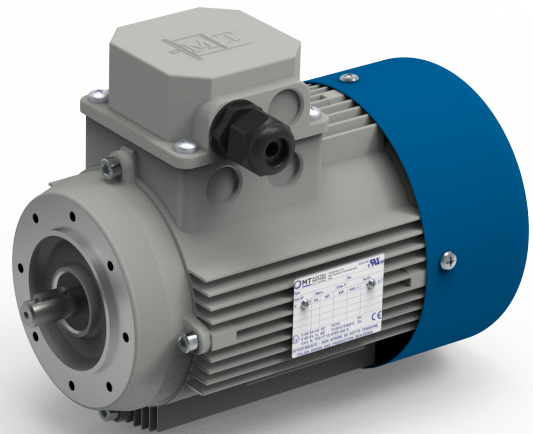
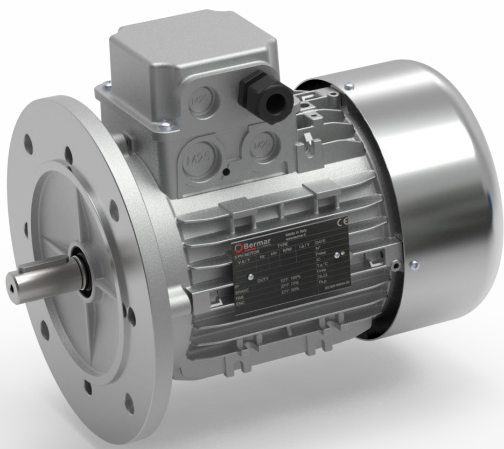

**B5**

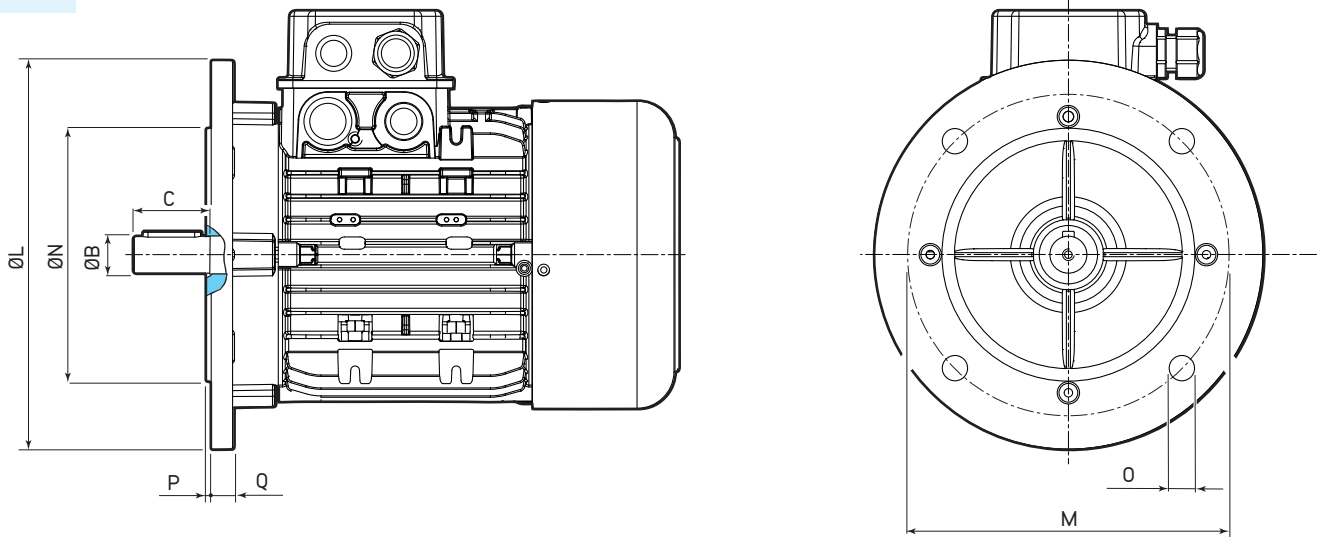

		4 poles	B	C	L	M	N	O	P	Q
		kW								
<b>56</b>	A	0.06	9	20	120	100	80	7	3	8
	B	0.09								
	C	0.11								
<b>63</b>	A	0.13	11	23	140	115	95	9	3	9
	B	0.18								
	C	0.22								
<b>71</b>	A	0.25	14	30	160	130	110	9	3.5	9
	B	0.37								
	C	0.55								
<b>80</b>	A	0.55	19	40	200	165	130	11	3.5	10
	B	0.75								
	C	0.9								
<b>90</b>	S	1.1	24	50	200	165	130	11	3.5	10
	L	1.5								
	LB	1.8								
<b>100</b>	A	2.2	28	60	250	215	180	14	4	14
	B	3								
	BL	4								
<b>112</b>	A	4	28	60	250	215	180	14	4	14
	BL	5.5								
	S	5.5								
<b>132</b>	M	7.5	38	80	300	265	230	14	4	20
	ML	9.2								
	M	11								
<b>160</b>	L	15	42	110	350	300	250	18	5	15
	M	18.5								
<b>180</b>	L	22	48	110	350	300	250	19	5	15
	M	30								
<b>200</b>	L	30	55	110	400	350	300	19	5	15
<b>225</b>	S	37	60	140	450	400	350	18	5	16
	M	45								

Motori elettrici disponibili vedi gamma:  
BerMar: [www.bermar.it](http://www.bermar.it)  
MT: [www.electricmotorsmt.com](http://www.electricmotorsmt.com)

Electric motors range available on:  
BerMar: [www.bermar.it](http://www.bermar.it)  
MT: [www.electricmotorsmt.com](http://www.electricmotorsmt.com)

Elektromotoren sind verfügbar auf:  
BerMar: [www.bermar.it](http://www.bermar.it)  
MT: [www.electricmotorsmt.com](http://www.electricmotorsmt.com)

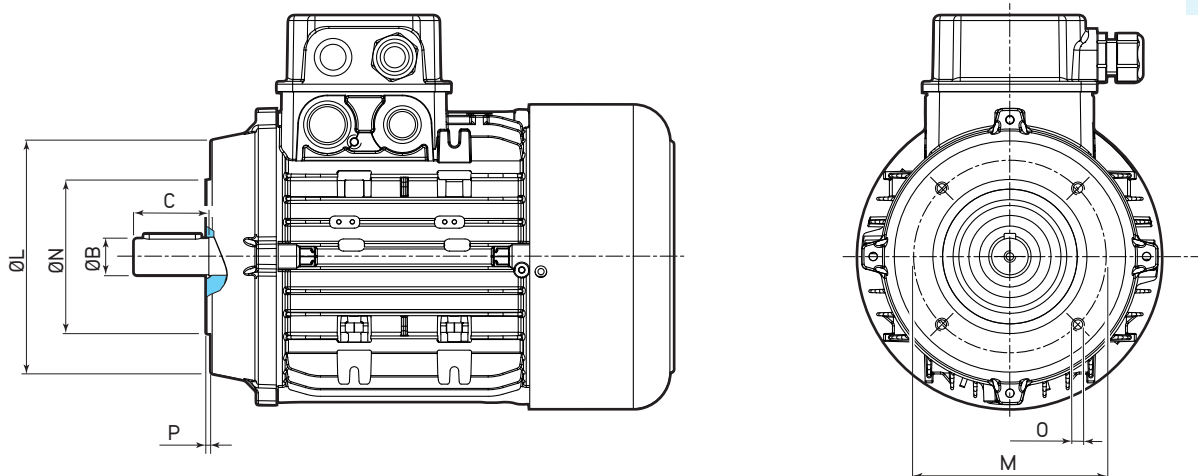
**B14**

		4 poles	B	C	L	M	N	O	P
		kW							
<b>56</b>	A	0.06	9	20	80	65	50	M5	2.5
	B	0.09							
	C	0.11							
<b>63</b>	A	0.13	11	23	90	75	60	M5	2.5
	B	0.18							
	C	0.22							
<b>71</b>	A	0.25	14	30	105	85	70	M6	2.5
	B	0.37							
	C	0.55							
<b>80</b>	A	0.55	19	40	120	100	80	M6	3
	B	0.75							
	C	0.9							
<b>90</b>	S	1.1	24	50	140	115	95	M8	3
	L	1.5							
	LB	1.8							
<b>100</b>	A	2.2	28	60	160	130	110	M8	3.5
	B	3							
	BL	4							
<b>112</b>	A	4	28	60	160	130	110	M8	3.5
	BL	5.5							
	S	5.5							
<b>132</b>	M	7.5	38	80	200	165	130	M10	4
	ML	9.2							

Motori elettrici disponibili vedi gamma:  
 BerMar: [www.bermar.it](http://www.bermar.it)  
 MT: [www.electricmotorsmt.com](http://www.electricmotorsmt.com)

Electric motors range available on:  
 BerMar: [www.bermar.it](http://www.bermar.it)  
 MT: [www.electricmotorsmt.com](http://www.electricmotorsmt.com)

Elektromotoren sind verfügbar auf:  
 BerMar: [www.bermar.it](http://www.bermar.it)  
 MT: [www.electricmotorsmt.com](http://www.electricmotorsmt.com)



## CONDIZIONI GENERALI DI VENDITA

Per consultare le condizioni di vendita si prega di fare riferimento al sito internet aziendale [tramec.it](http://tramec.it), nella sezione "Download" (link: [tramec.it/en/download](http://tramec.it/en/download)), consultare il documento denominato "Condizioni generali di vendita"

## TERMS AND CONDITIONS OF SALE

*Kindly refer to our Sales Conditions available on the "Download" area of our [tramec.it](http://tramec.it) website (link: [tramec.it/en/download](http://tramec.it/en/download)). You shall download the following file: "Sales Terms and Conditions".*

## ALLGEMEINE GESCHÄFTSBEDINGUNGEN

Bitte beachten Sie unsere Verkaufsbedingungen, die im Bereich "Download" unseres [Tramec.it](http://Tramec.it) webseite (Link: [tramec.it/en/download](http://tramec.it/en/download) ). Sie sollen die File "Sales Terms and Conditions" herunterladen.











*Production Sites:*

 **Tramec srl**  
Via Bizzarri, 6  
40012 - Calderara di Reno  
Bologna (Italy)  
[tramec.it](http://tramec.it)

 **Varmec srl**  
Via dell'Industria, 13  
36016 - Thiene  
Vicenza (Italy)  
[varmec.com](http://varmec.com)

 **MT Motori Elettrici srl**  
 **Bermar srl**  
via Bologna, 175  
40017 - San Giovanni in Persiceto  
Bologna (Italy)  
[electricmotorsmt.com](http://electricmotorsmt.com)  
[bermar.it](http://bermar.it)

*Italian Branches:*

**Italtech srl** (Centro)  
[italtech1.it](http://italtech1.it)

**Tramec Sud srl** (Sud)  
[tramecsud.it](http://tramecsud.it)

**Tramec Technology srl** (Nord)  
[tramectechology.it](http://tramectechology.it)

*Foreign Branches:*

**Tramec France sarl** (France)  
[tramec.fr](http://tramec.fr)

**Tramec Getriebe gmbh** (Germany)  
[tramec-getriebe.de](http://tramec-getriebe.de)

**Tramec Polska SP. Z O.O.** (Poland)  
[tramec.pl](http://tramec.pl)

 [moon-ind.com](http://moon-ind.com)



## Gamma prodotti | Product range

 **Riduttori | Gearboxes**



 **Riduttori e Motori CC | Gearboxes and DC motors**



 **Motori e Inverter | Motors and Inverter**

