

TECHNICAL CATALOGUE

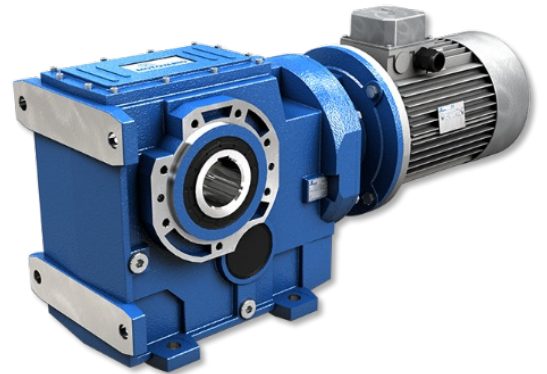

HELICAL BEVEL GEARED MOTORS

STANDARD **IEC**
DIRECTIVE **ATEX** 

1. GENERAL INFORMATION

1.1	ATEX	4
1.2	SYMBOLS AND FORMULAS	5
1.2.1	Symbols	5
1.2.2	Formulas	6
1.3	PRODUCT SELECTION	7
1.4	SERVICE FACTOR	8
1.5	INSTALLATION	9

2. PRODUCT INFORMATION

2.1	DESIGN FEATURES	10
2.2	TYOLOGY	11
2.2.1	Designation	11
2.2.2	Versions	12
2.2.3	Modularity	16
2.3	MOUNTING POSITIONS	18
2.3.1	Mounting positions	18
2.3.2	Position of terminal box	18
2.4	DIRECTION OF ROTATION	19
2.5	CRITICAL APPLICATIONS	20
2.5.1	Critical applications	20
2.5.2	Information	20
2.6	MOTOR FLANGE AVAILABILITY	21
2.6.1	BA Motor flange availability	21
2.6.2	B Motor flange availability	22
2.7	OUTPUT SHAFT BEARINGS	25
2.8	OVERHUNG LOAD	26
2.8.1	Information	26
2.8.2	Input	26
2.8.3	Output	27
2.9	LUBRICATION	28
2.9.1	Information	28
2.9.2	Lubricants	28

2.9.3	Special lubricants	29
2.9.4	Quantity	30
2.10	MOMENTS OF INERTIA	31

3. DIMENSIONS

3.1	REDUCERS/GEARED MOTORS	32
3.1.1	BA.2	32
3.1.2	BA.3	33
3.1.3	CBA.2	34
3.1.4	CBA.3	35
3.1.5	IBA.2	36
3.1.6	IBA.3	37
3.1.7	B	38
3.1.8	CB	40
3.1.9	IB	42
3.2	ELECTRIC MOTORS	44
3.2.1	Electric motors	44
3.2.2	Standard high efficiency (TS), high (TH) and premium- (TP) motors	46
3.2.3	Nominal power - [kW]	47
3.3	WEIGHT	48
3.4	END SHAFT	49

4. ACCESSORIES AND OPTIONS

4.1	LOW SPEED SHAFTS	50
4.2	OUTPUT FLANGE	51
4.2.1	BA	51
4.2.2	B	52
4.3	SHAFT MOUNTING FASTENING	53
4.3.1	Torque arm: BA Mounting position	53
4.3.2	Torque arm: BA Dimensions	53
4.3.3	Torque arm: B Mounting position	54
4.3.4	Torque arm: B063-083-103-123 Dimensions	55
4.3.5	Torque arm: B143-153-163 Dimensions	55
4.4	BACKSTOP DEVICE	56

4.5	OUTPUT SHAFT WITH SHRINK DISC	57
4.6	THERMAL PROTECTOR	58
4.7	REINFORCED OIL SEALS FOR OUTPUT SHAFT	59
4.8	ASSEMBLING/DISASSEMBLING KIT	60

5. ATEX AVAILABILITY

5.1	ATEX AVAILABILITY	61
-----	-------------------------	----

6. PERFORMANCES

6.1	B/BA GEARED MOTORS (50Hz)	62
6.2	IB/IBA GEAR REDUCER - 1750 rpm	113
6.3	IB/IBA GEAR REDUCER - 1400 rpm	121
6.4	IB/IBA GEAR REDUCER - 1140 rpm	129
6.5	IB/IBA GEAR REDUCER - 900 rpm	137
6.6	IB/IBA GEAR REDUCER - 700 rpm	145
6.7	IB/IBA GEAR REDUCER - 500 rpm	153

7. SALES CONDITIONS

7.1	SALES CONDITIONS	161
-----	------------------------	-----



ATEX Certification

The gear reducers described in this catalogue, defined as “ATEX”, were designed and manufactured in compliance with: Directive **ATEX 2014/34/UE**.

If used by following the instructions set forth in the INSTALLATION AND USE INSTRUCTIONS Atex Manual (provided as an attachment to the supplied products), ATEX MOTOVARIO gear reducers can be used in one of the following environments:

Group II

Category 2G and 2D

Zone 1/21 for gases and dusts (gas group IIB) with the following protection methods:

Protection against ignition:

EN13463-5 (c) constructional safety

EN13463-8 (k) liquid immersion

Group II

Category 3G and 3D

Zone 2/22 for gases and dusts

Protection against ignition:

EN13463-5 (c) constructional safety

The room temperature envisaged for the application must range between -20 and + 40 °C (*).

The products certified for use in Zone 1/21 can be used also in Zone 2/22. To identify the environment inside which the Atex certification of the special gear reducer is limited, refer to Atex Performance Tables.

The classified units are manufactured and marked to comply with the provisions of Directive **ATEX 2014/34/UE**.

UNINTENDED USE

It is strictly forbidden to use the gear reducer:

- inside an area with equipment category I (mines likely to become endangered by firedamp);
- inside an Area classified as more severe than specified on product label;
- at a room temperature not falling within the specified limits (*);
- under conditions (P1, n1, M2) that, even individually, exceed the values specified inside Atex Performance Tables.

1.2.1 Symbols

Physical dimension	Symbol	Symbol units of measure	Input	Output
Power	P	[kW]	P ₁	P ₂
Requested power	Pr	[kW]	Pr ₁	Pr ₂
Nominal power	Pn	[kW]	Pn ₁	Pn ₂
Torque	M	[Nm]	M ₁	M ₂
Nominal torque	Mn	[Nm]		Mn ₂
Requested torque	Mr	[Nm]	Mr ₁	Mr ₂
Speed	n	[rpm]	n ₁	n ₂
Force	F	[N]		
Radial load	Fr	[N]	Fr ₁	Fr ₂
Axial load	Fa	[N]	Fa ₁	Fa ₂
Reduction ratio	i			
Dynamic efficiency	η_d			
Service factor	f.s.			
Static	s			
Dynamic	d			
Calculated	c			
Maximum	max			
Minimum	min			
Moment of inertia	J	[kgm ²]	J ₁	
Ambient temperature	T _{amb}	[°C]		
Dimension		[mm]		

1.2.2 Formulas

REDUCER		
Starting or stopping time	$t = v / a$	[s]
Velocity in rotary motion	$v = \pi * d * n / 60$ $v = \omega * r$	[m/s]
Speed velocity Angular velocity	$n = 60 * v / (\pi * d)$ $\omega = v / r$	[rpm] [rad/s]
Acceleration or deceleration according to a starting / stopping time	$a = v / t$	[m/s ²]
Angular acceleration	$\alpha = n / (9,55 * t)$ $\alpha = \omega / t$	[rad/s ²]
Starting or stopping distance (according to acceleration / deceleration or angular velocity)	$s = a * t^2 / 2$ $s = v * t / 2$	[m]
Horizontal translation force	$F = \mu * m * g$	[N]
Vertical translation force (lifting)	$F = m * g$	
Inclined plane translation force	$F = m * g (\mu * \cos\beta + \sin\beta)$	
m= mass [kg]; g= gravity acceleration [m/s ²]; μ = friction coefficient; β = angle of inclination		
Moment of inertia	$J = m * v^2 / \omega^2$	[kgm ²]
Torque	$M = F * d / 2$ $M = J * \omega / t$	[Nm]

MOTOR and GEARMOTOR		
Starting time	$t_a = (J_{ext} + J_m) * n_n / 9,55 + (M_{peak} - M_r)$	[s]
Braking time	$t_s = (J_{ext} + J_m) * n_n / 9,55 + (M_{peak} + M_r)$	[s]
Motor rotation angle during starting	$\varphi = n_n * t_a / 19,1$	[rad]
Motor rotation angle during braking	$\varphi = n_n * t_s / 19,1$	[rad]
Power available at the shaft of single phase motor	$P = V * I * \eta * \cos\omega$	[W]
Power available at the shaft of three phase motor	$P = 1,73 * V * I * \eta * \cos\omega$	[W]

RUNNING at 60Hz		
Speed velocity at 60Hz	$n_{60Hz} = 1,2 * n_{50Hz}$	[rpm]
Power at 60Hz	$P_{1\ 60Hz} = P_{1\ 50Hz} * V_{60Hz} / V_{50Hz}$	[kW]
If input voltage at 60 Hz (V_{60Hz}) corresponds to winding voltage at 50 Hz (V_{50Hz}), power doesn't change $P_{1\ 60Hz} = P_{1\ 50Hz}$		
If input voltage at 60 Hz (V_{60Hz}) is 20% higher than winding voltage at 50 Hz (V_{50Hz}), power increases by 20% $P_{1\ 60Hz} = 1,2 P_{1\ 50Hz}$		
Torque at 60Hz	$M_{60Hz} = M_{50Hz} * P_{1\ 60Hz} / (1,2 * P_{1\ 50Hz})$	[Nm]
Service factor at 60Hz	$f.s_{60Hz} = f.s_{50Hz} * 1,175 * P_{1\ 50Hz} / P_{1\ 60Hz}$	-

For correctly selecting a gear reducer or geared motor, several essential pieces of data are required:

1. The rotational input speed to the gear reducer (n_1) and the rotational output speed (n_2). Through these two values it is possible to calculate the reduction ratio (i) of the gear reducer using the following formula: $i = n_1/n_2$
2. The torque required by the application (Mr_2).

The geared motor or gear reducer can be selected once this data is known.

This guide helps you to select the right product in just a few steps:

Geared motor selection

1. Determine the application's actual service factor (**s.f.**). This parameter depends on the type of load of the powered machine, the number of starts per hour and the hours of operation (refer to the "Service factor" paragraph).
2. Calculate the input power Pr_1 using the required torque value Mr_2 , the speed n_2 and dynamic efficiency value. $Pr_1 = (Mr_2 * n_2) / (9550 * \eta_d)$. The dynamic efficiency value depends on the type of gear reducer and on the number of gear reduction stages. (To calculate the efficiency value see its page).
3. Consult the geared motor performance tables and identify a normalised power value Pn_1 exceeding the required power Pr_1 , such that: $Pn_1 \geq Pr_1$
4. Once the suitable nominal power has been identified, select the geared motor capable of generating the rotational speed closest to the desired n_2 value and with service factor s.f. greater or equal to that required by the application.



For ATEX product selection, use the service factor "f.s. ATEX".

In the geared motor selection tables the combinations include 2-pole, 4-pole and 6-pole motors powered at 50Hz.

Gear reducer selection

1. Determine the application's service factor (**s.f.**) (consult to the "Service factor" paragraph on its page) .
2. Calculate the reduction ratio i from the requested output speed n_2 and from the input speed n_1 . $i = n_1/n_2$
3. Calculate the torque Mc_2 for selecting the gear reducer through the torque required by the application Mr_2 and the service factor s.f.: $Mc_2 = Mr_2 * (f.s.)$
4. Consult the Gear Reducer Performance tables looking for the reducer that, with the reduction ratio closer to the calculated one, has a nominal torque Mn_2 so that: $Mn_2 \geq Mc_2$



For ATEX product Selection, refer to ATEX Gear Reducer Performance tables.

Checks

Once the gear reducer or geared motor has been selected, the following checks should be performed:

A. Thermal power

The gear reducer's thermal power must be equal to or greater than the installed mechanical power, or the power required by the application according to the indications contained in the section (refer to the "Thermal power" paragraph).

B. Maximum torque

Generally, the maximum torque (peak instantaneous load) that can be applied to the gear reducer must not exceed 200% of the nominal torque Mn_2 (ATEX - M_2max).

C. Radial loads

1. Verify that the radial loads acting on the input and/or output shafts are within with the values indicated in the catalogue. If they exceed these values, increase the size of the gear reducer or modify the external load capacity. During the checking phase, it is important to remember that the values indicated in the catalogue refer to loads acting on the mid-point of the shaft protrusion, therefore, if the load is applied to a different position, appropriate formulas must be used to calculate the admissible load in the desired position (refer to the "Radial loads" paragraph).
2. If accessory output shafts are present, make sure that the applied load is compatible with shaft size. If help is needed: contact MOTOVARIO TECHNICAL SERVICE.

D. If an electric motor is going to be fitted to the selected gear reducer, check for its applicability by referring to the configuration table (see paragraph "Motor flange availability"). From IEC 180 motors, verify if necessary to support the motor with feet. In case of need please contact MOTOVARIO TECHNICAL SERVICE.

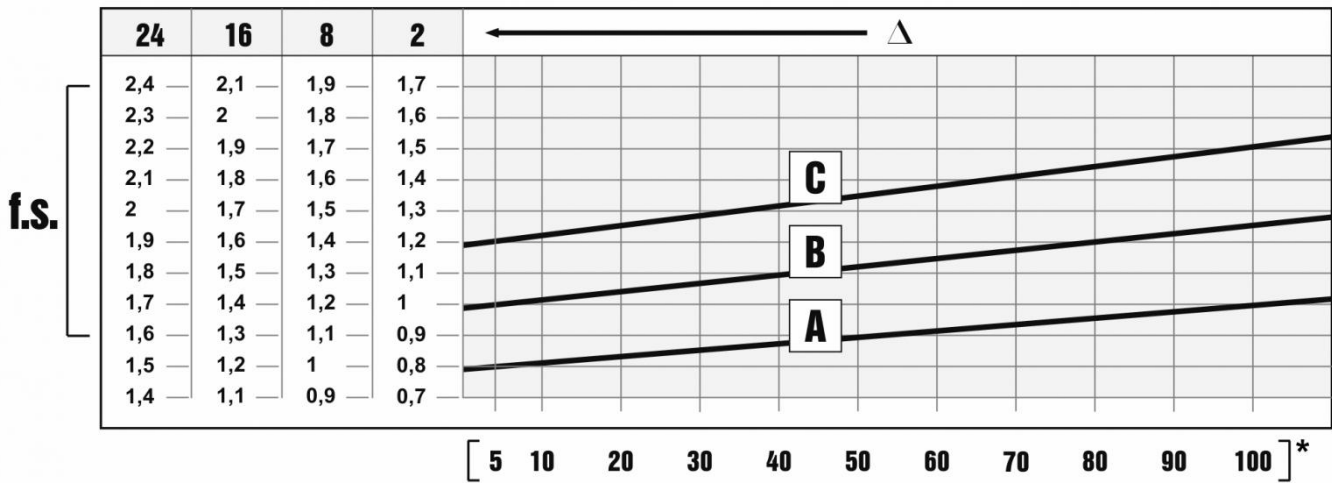

The service factor (f.s.) depends on the operating conditions the gear reducer is subjected to. The parameters that need to be taken into consideration to select the most adequate service factor correctly comprise:

- type of load of the operated machine : A - B - C
- length of daily operating time: hours/day (Δ)
- start-up frequency: starts/hour (*)

LOAD:

- **A** - uniform = $f_a \leq 0,3$
- **B** - moderate shocks = $f_a \leq 3$
- **C** - heavy shocks = $f_a \leq 10$

$f_a = J_e/J_m$

- J_e [kgm²] moment of reduced external inertia at the drive-shaft
- J_m [kgm²] moment of inertia of motor

If $f_a > 10$ call our Technical Service.

- A. Screw feeders for light materials, fans, assembly lines, conveyor belts for light materials, small mixers, lifts, cleaning machines, fillers, control machines.
- B. Winding devices, woodworking machine feeders, goods lifts, balancers, threading machines, medium mixers, conveyor belts for heavy materials, winches, sliding doors, fertilizer scrapers, packing machines, concrete mixers, crane mechanisms, milling cutters, folding machines, gear pumps.
- C. Mixers for heavy materials, shears, presses, centrifuges, rotating supports, winches and lifts for heavy materials, grinding lathes, stone mills, bucket elevators, drilling machines, hammer mills, cam presses, folding machines, turntables, tumbling barrels, vibrators, shredders.

To install the gear reducer it is necessary to note the following recommendations:

- Check the correct direction of rotation of the gear reducer output shaft before fitting the unit to the machine.
- In the case of particularly lengthy periods of storage (4/6 months), if the oil seal is not immersed in the lubricant inside the unit, it is recommended to change it since the rubber could stick to the shaft or may even have lost the elasticity it needs to function properly.
- Whenever possible, protect the gear reducer against solar radiation and bad weather.
- Ensure the motor cools correctly by ensuring good passage of air from the fan side.
- In the case of ambient temperatures $< -5^{\circ}\text{C}$ or $> +40^{\circ}\text{C}$ call the Technical Service.
- The various parts (pulleys, gear wheels, couplings, shafts, etc.) must be mounted on the shafts using special threaded holes or other systems that anyhow ensure correct operation without risking damage to the bearings or external parts of the units. Lubricate the surfaces in contact to avoid seizure or oxidation.
- Painting must definitely not go over rubber parts and the holes on the breather plugs, if any.
- For units equipped with oil plugs, replace the closed plug used for shipping with the special breather plug.
- Check the correct level of the lubricant through the indicator, if there is one.
- Starting must take place gradually, without immediately applying the maximum load.
- When there are parts, objects or materials under the motor drive that can be damaged by even limited spillage of oil, special protection should be fitted.

Assembling motor on pam flange

When the unit is supplied without motor, it is necessary to follow these recommendation to ensure the correct assembly of the electric motor. Check that the tolerances for the motor shaft and flange correspond to the "standard". Carefully clean the shaft, spigot and surfaces of the flange removing traces of paint and dirt, and confirm the key is fitted correctly. Fit the half coupling/sleeve to the motor shaft (see picture) taking care to ensure the motor shaft and bearings are not damaged by avoiding excessive force and where necessary using assembly equipment. Place the couplings elastic element onto the motor half coupling and position the motor up to the gear unit ensuring the coupling element is aligned with the driven half coupling. Complete the assembly using the fixing bolts. Key-ways with tightened tolerances.

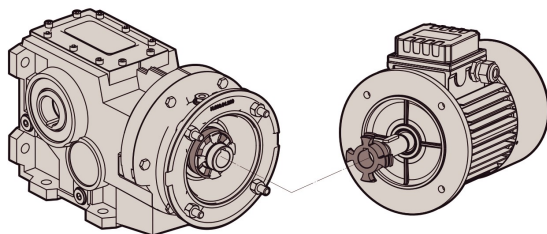
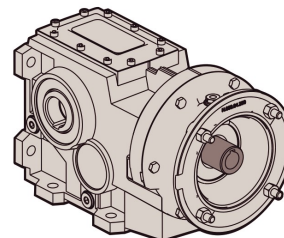

In case of ATEX units, fit gasket (to be requested to Motovario) between PAM flange and motor.

Flexible joint**PAM Sleeve**

Motovario products are supplied with the following surface treatment features:

Die-cast aluminium alloy cases for gears

Die-cast materials undergo the following surface cleaning operations:

- De-burring by means of a mechanically operated shearing system.
- Accurate shot-peening.
- Painting.
- Washing and passivation.

Grey-coloured cast-iron cases for gears

- Die-cast materials are always painted.

Painting specifications:

- Orange-peel blue epoxy-polyester RAL 5010. Polyester resin based heat-hardening powders, altered with epoxy resins.

Mechanical properties

- Tests carried out onto degreased Unichim white lattens (film thickness: 60 microns) comply with the following specifications: adherence (ISO2409).

Heat resistance

- 24 HOURS AT 150°C.

Corrosion strength

- ASTM B 117/97 salt fog from 100 to 500 hours depending on the support's preliminary treatment.

Performance:

- Loading capacity in accordance with DIN 3990, ISO 6336, AGMA 2101, ISO 10300, DIN 3991, ISO 281, DIN 743

Efficiency η :

- The efficiency is the ratio between the output power P_2 and the power absorbed by the gear reducer P_1 : $\eta = P_2 / P_1$

B/BA-range helical bevel gear reducers have an average value equal to:

B..3 stages = 0,9

BA.2 stages = 0,95

BA.3 stages = 0,9

2.2.1 Designation

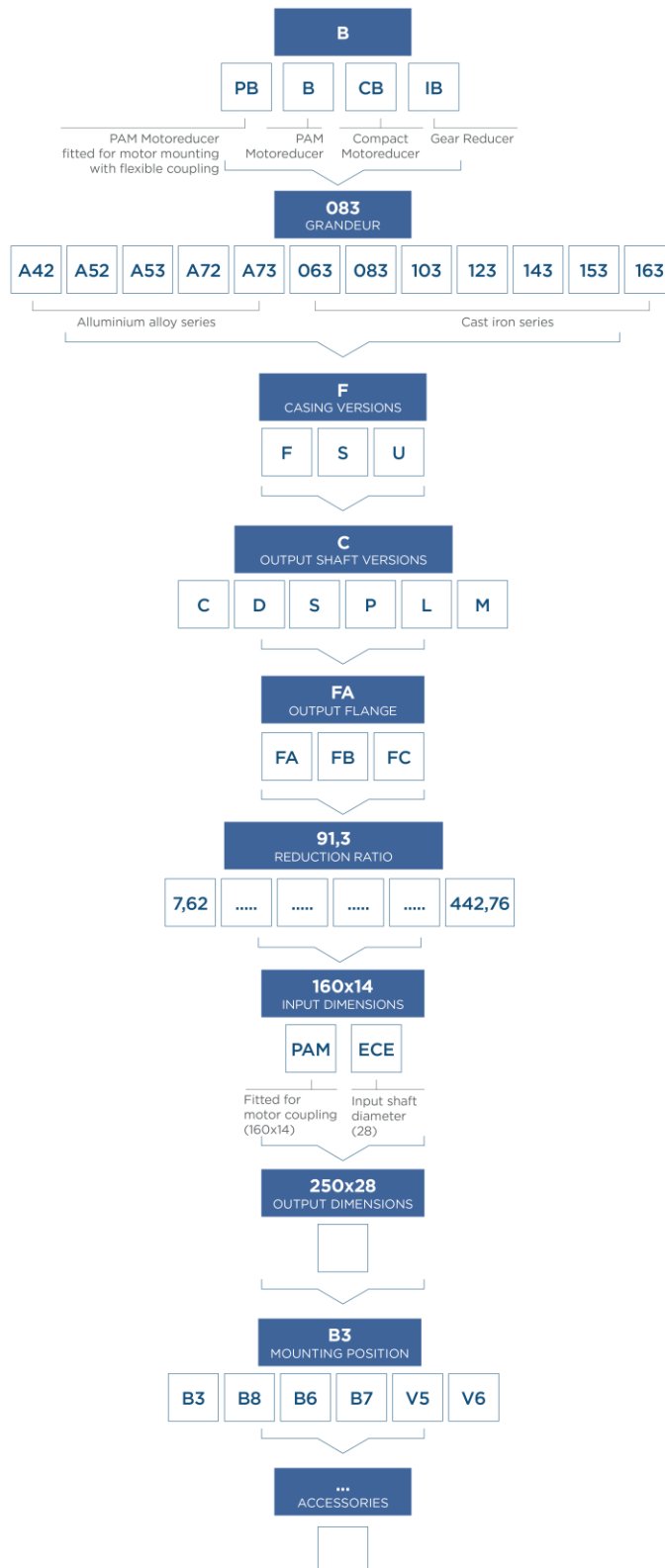

2.2.2 Versions

A40-A50-A70

C FOOT MOUNTING / HOLLOW SHAFT

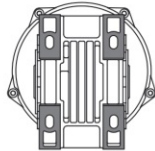
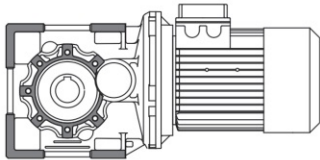

D FOOT MOUNTING / D SOLID SHAFT

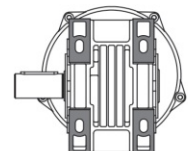
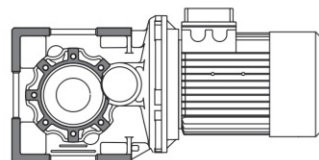

S FOOT MOUNTING / S SOLID SHAFT

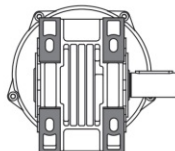
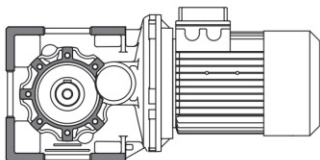

P FOOT MOUNTING / DOUBLE OUTPUT SHAFT

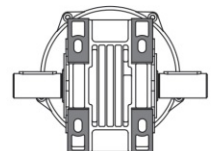
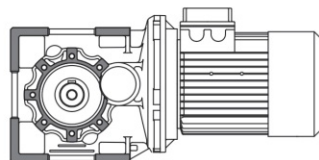

L FOOT MOUNTING / SHRINK DISC SHAFT

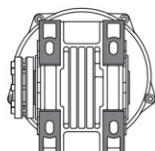
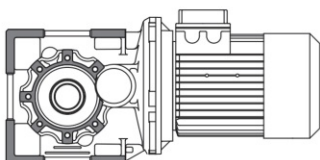

SIZES A42 - A52 - A53
ARE NOT AVAILABLE IN VERSIONS D-S-P



NOTE ATEX GEAR REDUCERS:
AVAILABLE FOR 3G/3D CERTIFICATION, ONLY.

063 - 083 - 103 - 123

FC FOOT MOUNTING / HOLLOW SHAFT

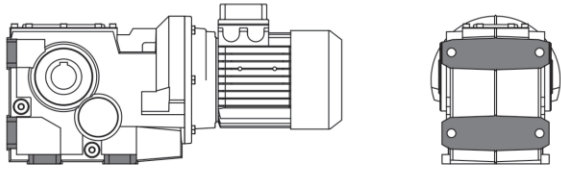

FD FOOT MOUNTING / D SOLID SHAFT

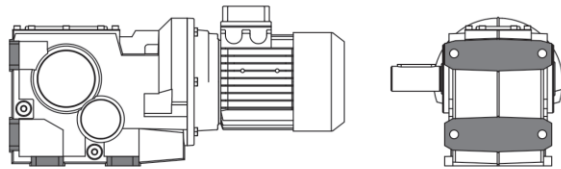

FS FOOT MOUNTING / S SOLID SHAFT

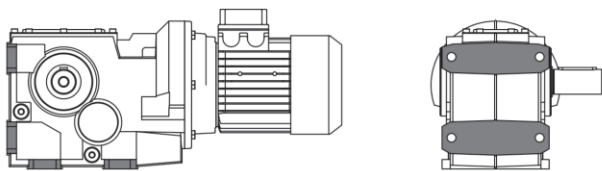

FP FOOT MOUNTING / DOUBLE OUTPUT SHAFT

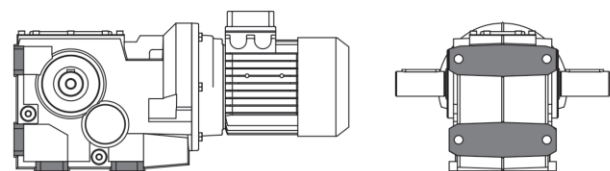

FL FOOT MOUNTING / SHRINK DISC SHAFT

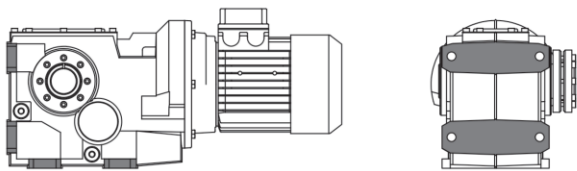

FM FOOT MOUNTING / SHRINK DISC SHAFT

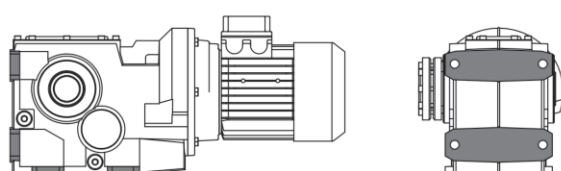

NOTE ATEX GEAR REDUCERS:
FL, FM VERSIONS ARE AVAILABLE FOR 3G/3D
CERTIFICATION, ONLY.

063 - 083 - 103 - 123

SC FLANGE MOUNTING / HOLLOW SHAFT

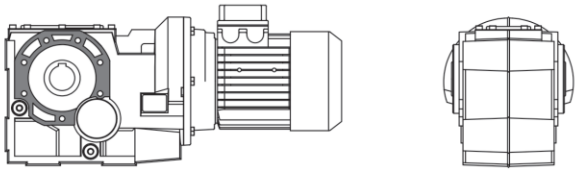

SD FLANGE MOUNTING / D SOLID SHAFT

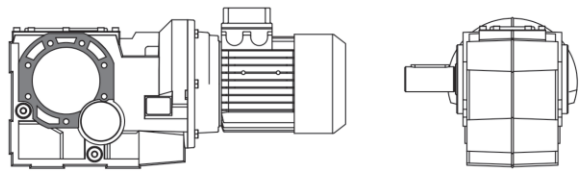

SS FLANGE MOUNTING / S SOLID SHAFT

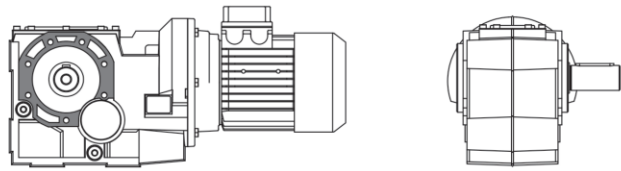

SP FLANGE MOUNTING / DOUBLE OUTPUT SHAFT

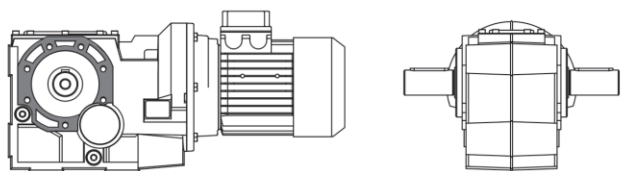

SL FLANGE MOUNTING / HOLLOW SHAFT

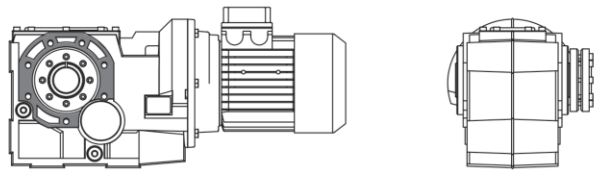

SM FLANGE MOUNTING / D SOLID SHAFT

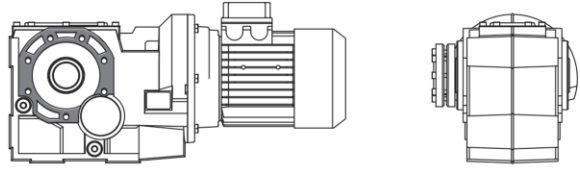

NOTE ATEX GEAR REDUCERS:
SL, SM VERSIONS ARE AVAILABLE FOR 3G/3D
CERTIFICATION, ONLY.

063 - 083 - 103 - 123 - 143 - 153 - 163

UC FOOT-FLANGE MOUNTING / HOLLOW SHAFT

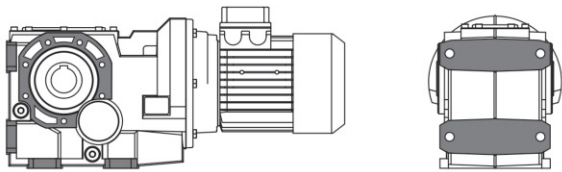

UD FOOT-FLANGE MOUNTING / D SOLID SHAFT

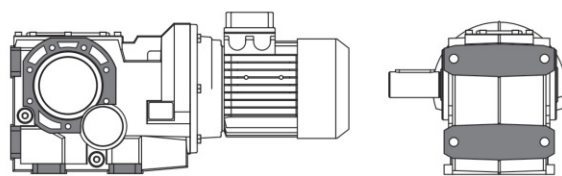

US FOOT-FLANGE MOUNTING / S SOLID SHAFT

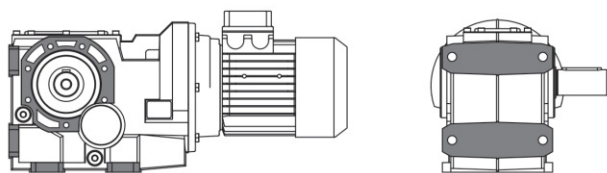

UP FOOT-FLANGE MOUNTING / DOUBLE OUTPUT SHAF

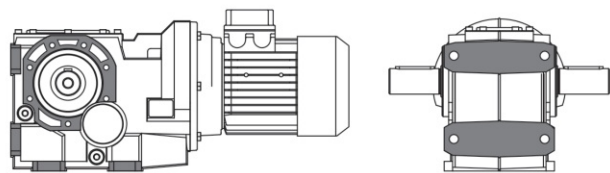

UL FOOT-FLANGE MOUNTING / SHRINK DISC SHAFT

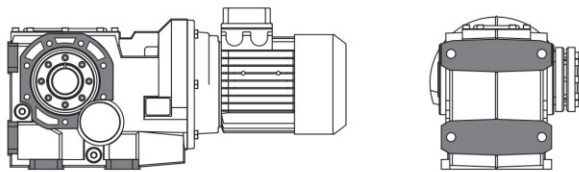

UM FOOT-FLANGE MOUNTING / SHRINK DISC SHAFT

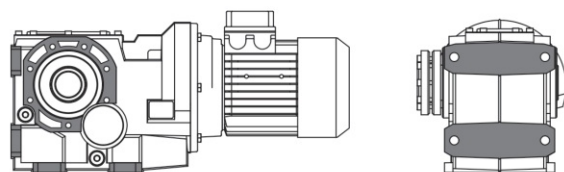

NOTE ATEX GEAR REDUCERS:
 UL, UM VERSIONS ARE AVAILABLE FOR 3G/3D
 CERTIFICATION, ONLY.

2.2.3 Modularity

BA ALUMINIUM ALLOY SERIES

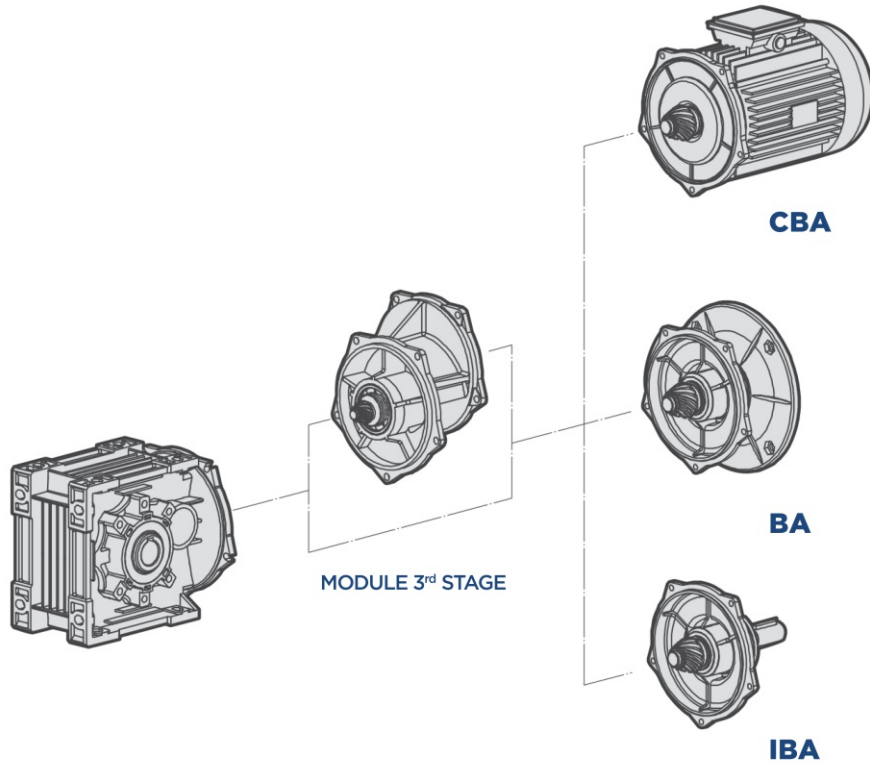

CBA

Compact electric motor versions

BA

Fitted for motor coupling version (PAM)

IBA

Input shaft versions

B GREY CAST IRON SERIES

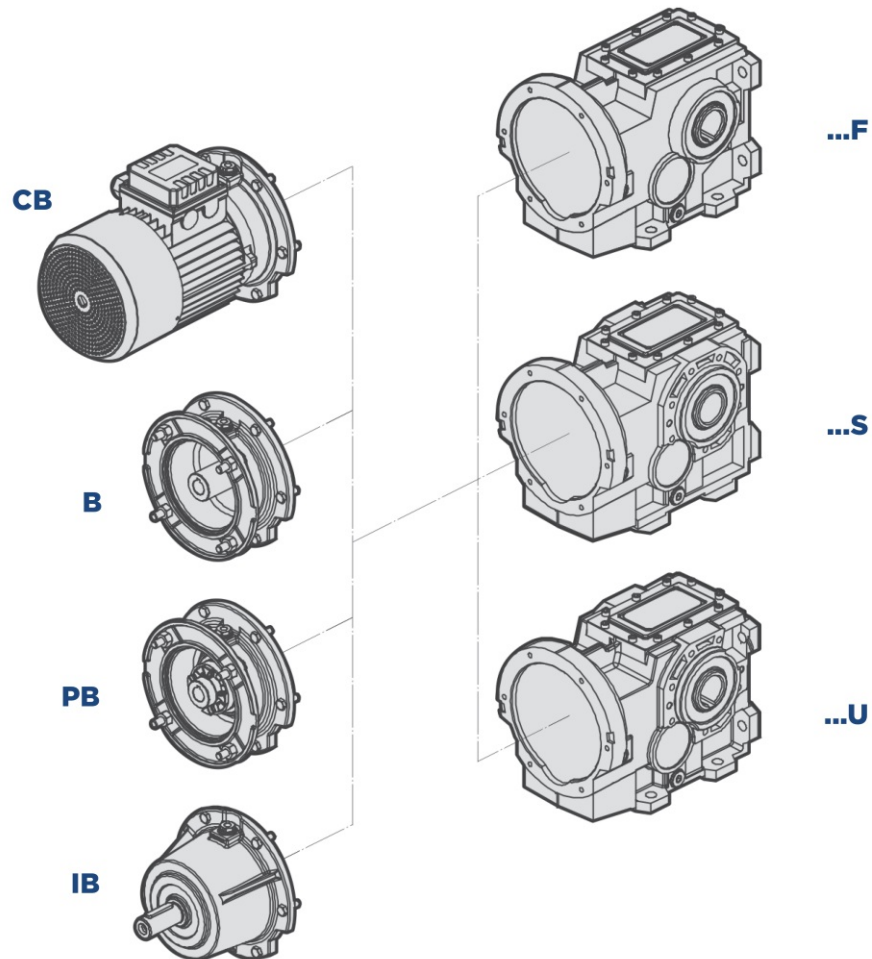

CB
Compact electric motor versions

PB
Fitted for motor mounting
with flexible coupling

B
Fitted for motor coupling version
(PAM)

IB
Input shaft versions

2.3.1 Mounting positions

The mounting position of the gear unit identifies its space orientation. B3 mounting position, as from a technical point of view, ensures lower oil splash, better lubrication and less heating.

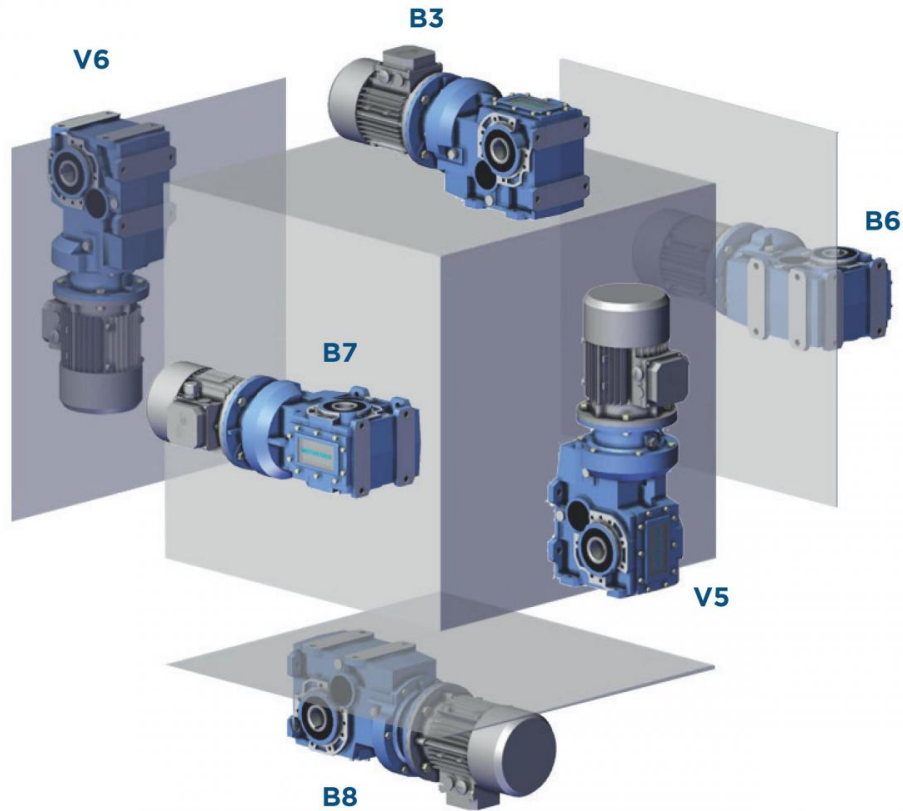

2.3.2 Position of terminal box

Unless otherwise specified when ordering, the gear reducer is supplied with terminal box in position 1.

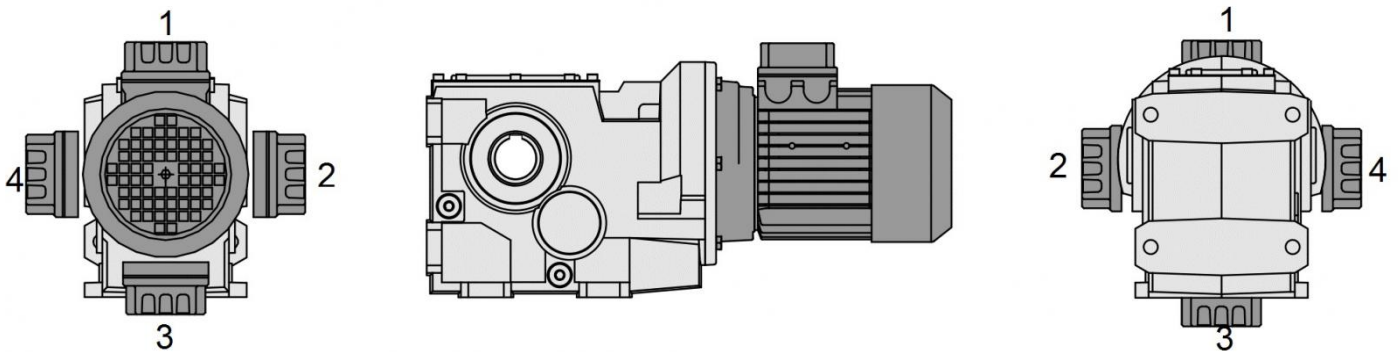

Helical bevel reduction units are supplied as “standard” with rotation as shown in the diagram. On request, the direction of rotation of low speed shaft can be reversed; in this case, it is necessary to specify “opposite rotation to catalogue” when ordering. The “opposite rotation to catalogue” is not possible for sizes BA42 - BA52 - BA53.

DIRECTION OF ROTATION - HIGH SPEED SHAFT

B-CB-IB A42-A52-A72

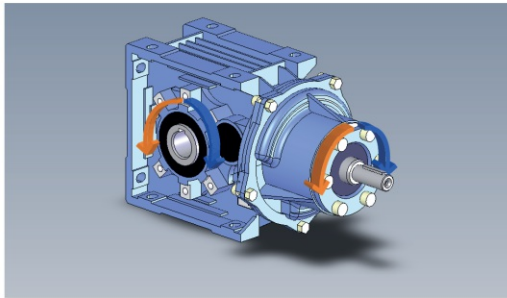

VERSIONS **C-D-P-L**

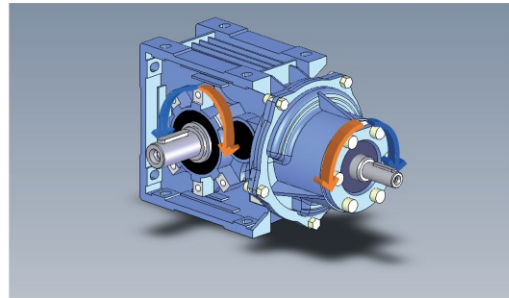

VERSION **S**

B-CB-IB A53-A73

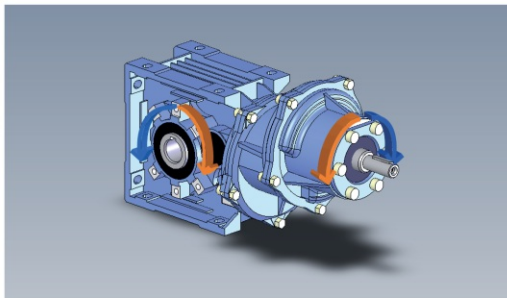

VERSIONS **C-D-P-L**

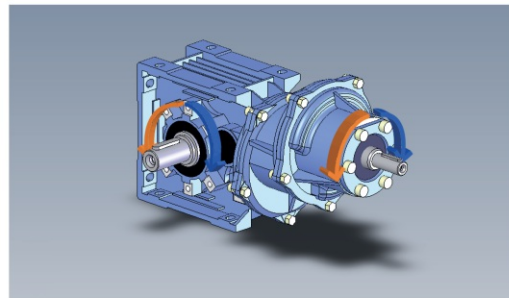

VERSION **S**

B-PB-CB-IB 063-163

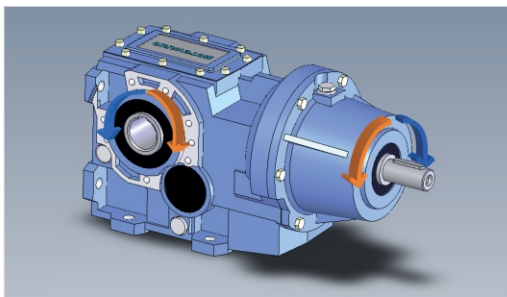

VERSIONS **C-D-P-L**

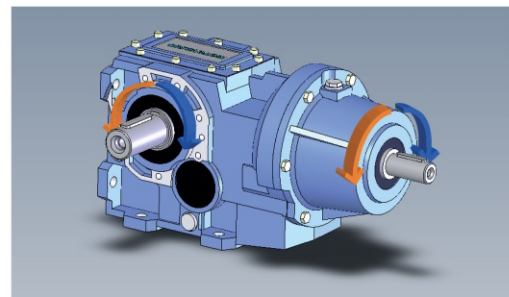

VERSION **S-M**

2.5.1 Critical applications

B	A40	A50	A70
2000 < n1 < 3000	✓	✓	✓
V6	B	B	B
n1 > 3000	B	B	B
...L : B6 - B7	B	B	B

B	060	080	100	125	140	150	160
2000 < n1 < 3000	✓	✓	✓	B	B	B	B
V6	B	B	B	B	B	B	B
n1 > 3000	B	B	B	B	A	A	A
...L : B6 - B7	B	B	B	B	B	B	B

✓ Verified application

A Application not recommended

B Check the application and/or call our technical service

The shrink disc is designed only to transmit the output torque.

In case of mounting position with radial and/or axial loads, please contact the technical support.

2.5.2 Information

The performance given in the catalogue correspond to mounting position B3 or similar, when the first stage is not entirely immersed in oil. For other mounting positions and/or particular input speeds, refer to the tables that highlight different critical situations for each size of gear reducer. It is also necessary to take due consideration of and carefully assess the following applications by calling our Technical Service:

- To avoid the use as multiplier.
- Use in services that could be hazardous for people if the gear reducer fails.
- Applications with especially high inertia.
- Use as a lifting winch.
- Applications with high dynamic strain on the case of the gear reducer.
- In places with T_{amb} under -5°C or over 40°C .
- Use in chemically aggressive environments.
- Use in a salty environment.
- Mounting positions not envisaged in the catalogue.
- Use in radioactive environments.
- Use in environments pressures other than atmospheric pressure.

Avoid applications where even partial immersion of the reducer is required.

In the presence of overloading due to full load, braking, shocks or other static and dynamic causes, please verify that the peak torque is less than $2 \cdot Mn_2$.

2.6.1 BA Motor flange availability

B10 = Compact electric motor versions.

These tables report all possible dimensions. Please verify service factor.



NOTE Atex gear reducers: available for 3G/3D certification, only.

	i	063	071	080	090	100	112
CB A42	7,62 ÷ 64,13	B10	B10	B10			
CB A42	78,17	B10	B10				
CB A52	7,91 ÷ 31,63	B10	B10	B10	B10		
CB A52	35,1 ÷ 64,87	B10	B10	B10			
CB A52	79,07	B10	B10				
CB A53	73,7 ÷ 172,53	B10	B10	B10	B10		
CB A53	197,11 ÷ 342,65	B10	B10				
CB A72	8,36 ÷ 22,19				B10	B10	B10
CB A72	27,45 ÷ 40,87			B10	B10	B10	B10
CB A72	45,64 ÷ 67,96			B10	B10		
CB A73	43,89 ÷ 222,93	B10	B10	B10	B10		
CB A73	260,2 ÷ 442,76	B10	B10				

	i	063	071	080	090	100	112
BA42	7,62 ÷ 64,13	B5	B5-B14	B5 - B14			
BA42	78,17	B5	B5-B14				
BA52	7,91 ÷ 31,63	B5	B5-B14	B5-B14	B5-B14		
BA52	35,1 ÷ 64,87	B5	B5-B14	B5-B14			
BA52	79,07	B5	B5-B14				
BA53	73,7 ÷ 172,53	B5	B5-B14	B5-B14	B5-B14		
BA53	197,11 ÷ 342,65	B5	B5-B14				
BA72	8,36 ÷ 22,19				B5-B14	B5-B14	B5-B14
BA72	27,45 ÷ 40,87			B5-B14	B5-B14	B5-B14	B5-B14
BA72	45,64 ÷ 67,96			B5-B14	B5-B14		
BA73	43,89 ÷ 222,93	B5	B5-B14	B5-B14	B5-B14		
BA73	260,2 ÷ 442,76	B5	B5-B14				

2.6.2 B Motor flange availability

B11 = Compact electric motor versions.

These tables report all possible dimensions. Please verify service factor.

*Configuration supplied with thermal protector.

**For motor size 063 the PB version does not exist.



NOTE Atex geared motors (versions with compact electric motor B11): available for 3G/3D certification, only.

CB - B - PB 063					
i	**063	071	080	090	100-112
5,71			B5-B11	B5-B11	B5-B11
6,88			B5-B11	B5-B11	B5-B11
7,32		B5-B11	B5-B11	B5-B11	B5-B11
9,16			B5-B11	B5-B11	B5-B11
10,26			B5-B11	B5-B11	B5-B11
11,03			B5-B11	B5-B11	B5-B11
12,35			B5-B11	B5-B11	B5-B11
13,15		B5-B11	B5-B11	B5-B11	B5-B11
15,18		B5-B11	B5-B11	B5-B11	B5-B11
17,00		B5-B11	B5-B11	B5-B11	B5-B11
22,39		B5-B11	B5-B11	B5-B11	B5-B11
26,09			B5-B11	B5-B11	B5-B11
28,03			B5-B11	B5-B11	B5-B11
33,43		B5-B11	B5-B11	B5-B11	B5-B11
38,58		B5-B11	B5-B11	B5-B11	B5-B11
43,22		B5-B11	B5-B11	B5-B11	B5-B11
50,81		B5-B11	B5-B11	B5-B11	B5-B11
56,93		B5-B11	B5-B11	B5-B11	B5-B11
69,16	B5-B11	B5-B11	B5-B11	B5-B11	
77,48	B5-B11	B5-B11	B5-B11	B5-B11	
90,33	B5-B11	B5-B11	B5-B11		
101,20	B5-B11	B5-B11	B5-B11		
111,74	B5-B11	B5-B11	B5-B11		
124,20	B5-B11	B5-B11	B5-B11		
139,15	B5-B11	B5-B11	B5-B11		
157,42	B5-B11	B5-B11	B5-B11		

CB - B - PB 083					
i	080	090	100	112	132
7,81	B5-B11	B5-B11	B5-B11	B5-B11	B5-B11
8,62	B5-B11	B5-B11	B5-B11	B5-B11	B5-B11
10,49	B5-B11	B5-B11	B5-B11	B5-B11	B5-B11
11,59	B5-B11	B5-B11	B5-B11	B5-B11	B5-B11
14,43	B5-B11	B5-B11	B5-B11	B5-B11	B5-B11
16,60	B5-B11	B5-B11	B5-B11	B5-B11	B5-B11
18,32	B5-B11	B5-B11	B5-B11	B5-B11	B5-B11
22,82	B5-B11	B5-B11	B5-B11	B5-B11	B5-B11
26,71	B5-B11	B5-B11	B5-B11	B5-B11	B5-B11
29,50	B5-B11	B5-B11	B5-B11	B5-B11	B5-B11
31,80	B5-B11	B5-B11	B5-B11	B5-B11	B5-B11
34,49	B5-B11	B5-B11	B5-B11	B5-B11	B5-B11
39,60	B5-B11	B5-B11	B5-B11	B5-B11	B5-B11
42,95	B5-B11	B5-B11	B5-B11	B5-B11	B5-B11
45,44	B5-B11	B5-B11	B5-B11	B5-B11	B5-B11
51,19	B5-B11	B5-B11	B5-B11	B5-B11	B5-B11
55,52	B5-B11	B5-B11	B5-B11	B5-B11	B5-B11
59,96	B5-B11	B5-B11	B5-B11	B5-B11	B5-B11
63,74	B5-B11	B5-B11	B5-B11	B5-B11	B5-B11
69,14	B5-B11	B5-B11	B5-B11	B5-B11	B5-B11
73,14	B5-B11	B5-B11	B5-B11	B5-B11	B5-B11
80,76	B5-B11	B5-B11	B5-B11	B5-B11	B5-B11
92,19	B5-B11	B5-B11	B5-B11	B5-B11	
100,57	B5-B11	B5-B11	B5-B11	B5-B11	B5-B11
105,29	B5-B11	B5-B11	B5-B11	B5-B11	
116,25	B5-B11	B5-B11	B5-B11	B5-B11	
126,76	B5-B11	B5-B11	B5-B11	B5-B11	
144,77	B5-B11	B5-B11	B5-B11	B5-B11	

2.6 MOTOR FLANGE AVAILABILITY

CB - B - PB 103						
i	080	090	100	112	132	160
*17,27	B5-B11	B5-B11	B5-B11	B5-B11	B5-B11	B5
*19,06	B5-B11	B5-B11	B5-B11	B5-B11	B5-B11	B5
*23,7	B5-B11	B5-B11	B5-B11	B5-B11	B5-B11	B5
*26,51	B5-B11	B5-B11	B5-B11	B5-B11	B5-B11	B5
*30,55	B5-B11	B5-B11	B5-B11	B5-B11	B5-B11	B5
*33,07	B5-B11	B5-B11	B5-B11	B5-B11	B5-B11	
*35,87	B5-B11	B5-B11	B5-B11	B5-B11	B5-B11	
*41,12	B5-B11	B5-B11	B5-B11	B5-B11	B5-B11	
*44,61	B5-B11	B5-B11	B5-B11	B5-B11	B5-B11	
*47,28	B5-B11	B5-B11	B5-B11	B5-B11	B5-B11	
*50,24	B5-B11	B5-B11	B5-B11	B5-B11	B5-B11	
53,02	B5-B11	B5-B11	B5-B11	B5-B11	B5-B11	
58,50	B5-B11	B5-B11	B5-B11	B5-B11	B5-B11	
64,89	B5-B11	B5-B11	B5-B11	B5-B11	B5-B11	
68,58	B5-B11	B5-B11	B5-B11	B5-B11	B5-B11	
72,76	B5-B11	B5-B11	B5-B11	B5-B11	B5-B11	
78,92	B5-B11	B5-B11	B5-B11	B5-B11	B5-B11	
83,66	B5-B11	B5-B11	B5-B11	B5-B11	B5-B11	
92,31	B5-B11	B5-B11	B5-B11	B5-B11	B5-B11	
105,44	B5-B11	B5-B11	B5-B11	B5-B11		
114,80	B5-B11	B5-B11	B5-B11	B5-B11	B5-B11	
120,42	B5-B11	B5-B11	B5-B11	B5-B11		
132,87	B5-B11	B5-B11	B5-B11	B5-B11		
144,69	B5-B11	B5-B11	B5-B11	B5-B11		
165,25	B5-B11	B5-B11	B5-B11	B5-B11		

CB - B - PB 123						
i	090	100	112	132	160	180
*7,97				B5-B11	B5	B5
*9,62				B5-B11	B5	B5
*10,33				B5-B11	B5	B5
*12,48				B5-B11	B5	B5
*13,84				B5-B11	B5	B5
*15,38				B5-B11	B5	B5
*18,58				B5-B11	B5	B5
*20,61				B5-B11	B5	B5
*22,78				B5-B11	B5	B5
*25,89		B5-B11	B5-B11	B5-B11	B5	B5
*27,51				B5-B11	B5	B5
*30,79				B5-B11	B5	B5
*31,26		B5-B11	B5-B11	B5-B11	B5	B5
*34,68		B5-B11	B5-B11	B5-B11	B5	B5
*40,53		B5-B11	B5-B11	B5-B11	B5	B5
*44,89		B5-B11	B5-B11	B5-B11	B5	B5
*49,80		B5-B11	B5-B11	B5-B11	B5	B5
54,30		B5-B11	B5-B11	B5-B11	B5	B5
59,36		B5-B11	B5-B11	B5-B11	B5	B5
62,59		B5-B11	B5-B11	B5-B11	B5	B5
69,43		B5-B11	B5-B11	B5-B11	B5	B5
74,42		B5-B11	B5-B11	B5-B11	B5	B5
80,04	B5-B11	B5-B11	B5-B11	B5-B11		
89,87		B5-B11	B5-B11	B5-B11	B5	B5
99,70		B5-B11	B5-B11	B5-B11	B5	B5
106,65	B5-B11	B5-B11	B5-B11	B5-B11		
119,60	B5-B11	B5-B11	B5-B11	B5-B11		
129,96	B5-B11	B5-B11	B5-B11	B5-B11		
144,43	B5-B11	B5-B11	B5-B11	B5-B11		
160,23	B5-B11	B5-B11	B5-B11	B5-B11		
180,40	B5-B11	B5-B11	B5-B11	B5-B11		

2.6 MOTOR FLANGE AVAILABILITY

CB - B - PB 143						
i	100	112	132	160	180	200
*10,84			B5-B11	B5	B5	B5
*11,87			B5-B11	B5	B5	B5
*14,49			B5-B11	B5	B5	B5
*17,04			B5-B11	B5	B5	B5
*18,66			B5-B11	B5	B5	B5
*21,00			B5-B11	B5	B5	B5
*22,77			B5-B11	B5	B5	B5
*25,63			B5-B11	B5	B5	B5
*27,44	B5-B11	B5-B11	B5-B11	B5	B5	B5
*30,05	B5-B11	B5-B11	B5-B11	B5	B5	B5
*33,01			B5-B11	B5	B5	B5
*36,67	B5-B11	B5-B11	B5-B11	B5	B5	B5
*40,29			B5-B11	B5	B5	B5
*44,16	B5-B11	B5-B11	B5-B11	B5	B5	B5
*48,35	B5-B11	B5-B11	B5-B11	B5	B5	B5
53,16	B5-B11	B5-B11	B5-B11	B5	B5	B5
54,63	B5-B11	B5-B11	B5-B11	B5	B5	B5
59,02	B5-B11	B5-B11	B5-B11	B5	B5	B5
64,88	B5-B11	B5-B11	B5-B11	B5	B5	B5
70,43	B5-B11	B5-B11	B5-B11	B5	B5	
77,12	B5-B11	B5-B11	B5-B11	B5	B5	
85,54	B5-B11	B5-B11	B5-B11	B5	B5	B5
94,13	B5-B11	B5-B11	B5-B11	B5	B5	
105,83	B5-B11	B5-B11	B5-B11			
111,94	B5-B11	B5-B11	B5-B11	B5	B5	
124,62	B5-B11	B5-B11	B5-B11	B5	B5	
136,44	B5-B11	B5-B11	B5-B11	B5	B5	
149,59	B5-B11	B5-B11	B5-B11	B5	B5	
166,53	B5-B11	B5-B11	B5-B11	B5	B5	
187,24	B5-B11	B5-B11	B5-B11			

B - PB 153					
i	132	160	180	200	225
*10,49		B5	B5	B5	B5
*12,64		B5	B5	B5	B5
*14,01		B5	B5	B5	B5
*15,40		B5	B5	B5	B5
*18,56		B5	B5	B5	B5
*20,56		B5	B5	B5	B5
*23,86		B5	B5	B5	B5
*25,19	B5	B5	B5	B5	B5
*28,23	B5	B5	B5	B5	B5
*30,35	B5	B5	B5	B5	B5
*33,63	B5	B5	B5	B5	B5
*35,02		B5	B5	B5	B5
*38,81		B5	B5	B5	B5
*42,30	B5	B5	B5	B5	B5
*47,53	B5	B5	B5	B5	B5
*50,56	B5	B5	B5	B5	B5
54,64	B5	B5	B5	B5	B5
57,27	B5	B5	B5	B5	B5
60,92	B5	B5	B5	B5	B5
63,47	B5	B5	B5	B5	B5
71,10	B5	B5	B5		
77,22	B5	B5	B5	B5	B5
83,90	B5	B5	B5		
87,70	B5	B5	B5		
93,05	B5	B5	B5	B5	B5
103,12	B5	B5	B5	B5	B5
123,90	B5	B5	B5		
134,30	B5	B5	B5		
149,30	B5	B5	B5		
165,40	B5	B5	B5		

B - PB 163						
i	160	180	200	225	250	280
*8,89		B5	B5	B5	B5	B5
*10,58		B5	B5	B5	B5	B5
*11,87		B5	B5	B5	B5	B5
*12,81		B5	B5	B5	B5	B5
*14,08		B5	B5	B5	B5	B5
*15,52		B5	B5	B5	B5	B5
*16,39		B5	B5	B5	B5	B5
*18,02	B5	B5	B5	B5	B5	B5
*19,96	B5	B5	B5	B5	B5	
*21,94	B5	B5	B5	B5	B5	B5
*24,17	B5	B5	B5	B5	B5	B5
*26,58	B5	B5	B5	B5	B5	B5
*28,80	B5	B5	B5	B5	B5	
*30,92	B5	B5	B5	B5	B5	B5
*34,25	B5	B5	B5	B5	B5	
*37,66	B5	B5	B5	B5	B5	
*40,65	B5	B5	B5	B5	B5	
*45,09	B5	B5	B5	B5	B5	
51,00	B5	B5	B5	B5	B5	
53,63	B5	B5	B5	B5	B5	
58,97	B5	B5	B5	B5	B5	
69,78	B5	B5	B5	B5		
76,72	B5	B5	B5			
87,54	B5	B5	B5			
96,25	B5	B5	B5			
103,93	B5	B5	B5			
114,27	B5	B5				
126,29	B5	B5				
138,85	B5	B5				
154,83	B5	B5				

2.7 OUTPUT SHAFT BEARINGS

BA		BA40		BA50		BA70	
Versions (*)		Standard	On request	Standard	On request	Standard	On request
U	C	1	/	1	/	1	/
	D/S/P	/	/	/	/	1	/
	L/M	1	/	1	/	1	/

(*) N.B. sizes A42 - A52 - A53 are not available in versions D-S-P.

B		B060		B080		B100/125		B140/150/160	
Versions		Standard	On request	Standard	On request	Standard	On request	Standard	On request
U	C	2	/	2 (Ø40)	1 (Ø45)	2	/	2	/
	D/S/P	2	/	2	/	2	/	2	/
	L/M	1	/	1	/	1	/	2	/
F/S	C	1	2	1	2	1	2	/	/
	D/S/P	2	/	2	/	2	/	/	/
	L/M	1	/	1	/	1	/	/	/

1 - Ball Bearing

2 - Roller bearings

/ - Not available

2.8.1 Information

The value of the admissible radial load [N] is given in the tables relating to the performance of the gear reducer at issue. It is related to the load applied on the centre line of the shaft and in the most unfavourable conditions of angle of application and direction of rotation. The maximum admissible axial loads are 1/5 of the value of the given radial load when they are applied in combination with the radial load. The tables relating to the output shafts give the maximum admissible value. This value must never be exceeded since it relates to the strength of the case. Particular conditions of radial load higher than the limits of the catalogue may occur. In this case, call our Technical Service and provide details on the application: direction of the load, direction of rotation of the shaft, type of service. In case of double extension shafts with radial load applied on both ends, the max. admissible radial loads must be defined according to the specific running conditions, in this case call our Technical Service. The radial load on the shaft is calculated with the following formula:

$$Fr_e = (2000 * M * fz) / D \leq Fr_1 \text{ or } Fr_2$$

- **Fr_e** [N] Resulting radial load
- **M** [Nm] Torque on the shaft
- **D** [mm] Diameter of the transmission member mounted on the shaft
- **Fr₁-Fr₂** [N] Value of the maximum admitted radial load (see relative tables)
- **fz** = 1,1 gear pinion - 1,4 chain wheel - 1,7 v-pulley - 2,5 flat pulley

2.8.2 Input

When the radial load is not on the centre line of the shaft, it is necessary to adjust the admissible radial load Fr₁ with the following formula: $Fr_x = (Fr_1 * a) / (b + x)$

- **a, b** = values given in the tables
- **x** = distance from the point of application of the load to the shaft shoulder

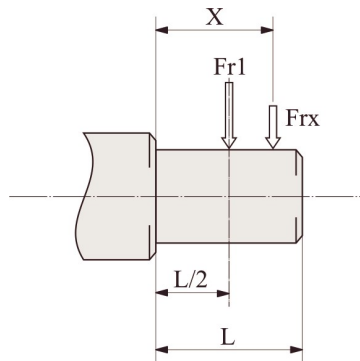

IB	A42 A52 A53 A73	A72
a	84	89
b	64	69
Fr1 max (**)	500	830

IB	063	083	103	123	143	153	163
a	105	137	137	175	175	225	221
b	80	108	108	135	135	170	166
Fr1 max (**)	2200	2500	3200	4200	7000	10000	12000

(**Fr₁ max) Max admissible value of the reducer in static conditions and/or for limited operations. For continuous overhung loads please check the values on the performances tables calculated according to the casing, the shaft and bearings.

2.8.3 Output

When the radial load is not on the centre line of the shaft, it is necessary to adjust the admissible radial load Fr2 with the following formula: $Fr_x = (Fr_2 \cdot a) / (b + x)$

- a , b = values given in the tables
- x = distance from the point of application of the load to the shaft shoulder

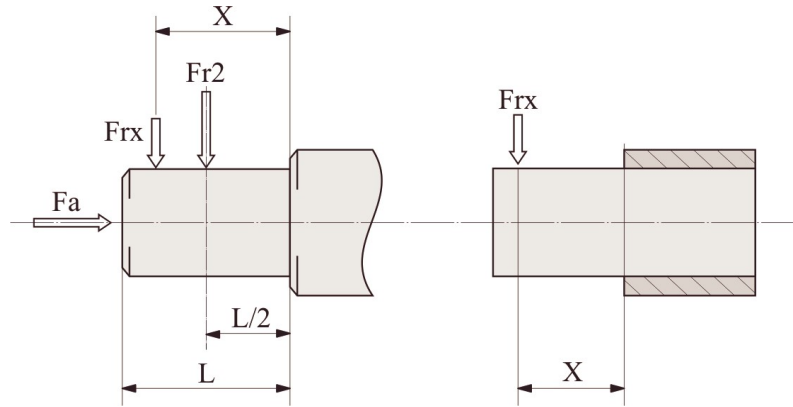

B	A42	A52 A53	A72 A73
a	105	119	145
b	85	94	116
D-S-P (Fr2 max **)	-	-	10000
C (Fr2 max **)	4000	4000	5500

B	063	083	103	123	143	153	163
a	129	190	225	262	306	348	468
b	100	150	175	202	236	278	363
D-S-P (Fr2 max **)	12000	18000	22000	30000	40000	65000	80000
C (Fr2 max **)	8000	12000	15000	20000	40000	65000	65000

(**Fr2 max) Max admissible value of the reducer in static conditions and/or for limited operations. For continuous overhung loads please check the values on the performances tables calculated according to the casing, the shaft and bearings.

2.9.1 Information

In cases of ambient temperatures not envisaged in the table, call our Technical Service. In the case of temperatures under -30°C or over 60°C it is necessary to use oil seals with special properties. For operating ranges with temperatures under 0°C it is necessary to consider the following:

1. The motors need to be suitable for operation at the envisaged ambient temperature.
2. The power of the electric motor needs to be adequate for exceeding the higher starting torques required.
3. In case of cast-iron gear reducers, pay attention to impact loads since cast iron may have problems of fragility at temperatures under -15°C.
4. During the early stages of service, problems of lubrication may arise due to the high level of viscosity taken on by the oil and so it is wise to have a few minutes of rotation under no load.



For ATEX gear reducers:

- Change oil as specified in the "Maintenance" table of the relevant "Use and Installation Instructions" manual (supplied with products).
- The use of oils other than the original one is forbidden.

2.9.2 Lubricants

Specifications of lubricants recommended by Motovario.

All units are supplied with ENI BLASIA 220 oil, unless otherwise specified by the client.

	B063 ÷ 163		BA42 ÷ A72/3
	Mineral oil		Mineral oil
T _{amb} °C ISO/SAE	(-5) ÷ (+40) ISO VG220	(-15) ÷ (+25) ISO VG150	(-5) ÷ (+40) SAE 85W-140
ENI	BLASIA 220	BLASIA 150	ROTRA MP (85W-140)
SHELL	OMALA S2 G 220	OMALA S2 G 150	SPIRAX S2 A 85W-140
KLUBER	Kluberoil GEM 1-220N	Kluberoil GEM 1-150N	Klubersynth GH 6-460
MOBIL	MOBILGEAR 600 XP220	MOBILGEAR 600 XP150	-
CASTROL	ALPHA SP 220	ALPHA SP 150	-
BP	ENERGOL GR-XP220	ENERGOL GR-XP150	-

2.9.3 Special lubricants

	$T_{amb}^{\circ C}$	Polyglycol synthetic oil
ENI	(-30) ÷ (+30)	Blasia S 150 (ISO VG150)
	(-20) ÷ (+40)	Blasia S 220 (ISO VG220)
MOBIL	(-45) ÷ (+0)	SCH 624 (ISO VG32)
	(-40) ÷ (+5)	SCH 626 (ISO VG68)
KLUBER	(-40) ÷ (+5)	Klubersynth GH 6-32 (ISO VG32)
	(-35) ÷ 10)	Klubersynth GH 6-80 (ISO VG80)
	(-30) ÷ (+40)	Klubersynth GH 6-150 (ISO VG150)
	(-25) ÷ (+40)	Klubersynth GH 6-220 (ISO VG220)
	(-15) ÷ (+50)	Klubersynth GH 6-460 (ISO VG460)
	(-10) ÷ (+70)	Klubersynth GH 6-680 (ISO VG680)
	$T_{amb}^{\circ C}$	Polyglycol synthetic oil for food grade
KLUBER	(-30) ÷ (+15)	Klubersynth UH1-6 100 (ISO VG100)
	(-25) ÷ (+40)	Klubersynth UH1-6 220 (ISO VG220)
	(-15) ÷ (+40)	Klubersynth UH1-6 320 (ISO VG320)
	(-15) ÷ (+50)	Klubersynth UH1-6 460 (ISO VG460)
	(-10) ÷ (+50)	Klubersynth UH1-6 680 (ISO VG680)

If 'special' lubricant is required please contact for Technical Assistance.

2.9.4 Quantity

- For the reduction units B series it is always necessary to specify the mounting position.
- The reduction units BA.. series with 2, 3 stages and B060, are supplied complete with lubricant, have no oil plugs and need no maintenance.
- The gear reducer B series sizes 080, 100, 125, 140, 150, 160 are supplied complete with lubricant and are fitted with oil plugs to suit any mounting position included in the catalogue.

It is recommended, after installation, to replace the closed plug used for transportation with the supplied breather plug. Oil quantity in the table (litres ~) are indicative; for a proper use you will have to refer to the level plug or the dipstick. Any level difference could depend on construction tolerances, but also by the placement of the unit or by the mounting surface at the customer's premises. It is appropriate to check and, if necessary, restores the level when the units are installed.

B	A42	A52	A53	A72	A73
B3	0,33	0,42	0,63	1	1,21
B8					
B6/B7					
V5					
V6					

CB	A42	A52	A53	A72	A73
B3	0,33	0,42	0,55	1	1,13
B8					
B6/B7					
V5					
V6					

B-CB	063	083	103	123	143	153	163
B3	1,2	2,5	3,7	5,7	11,1	19	33
B8	1,5	2,8	4,2	7,9	13	17,5	42,8
B6	1,5	3,5	6	8,5	14,5	26	43
B7	1,5	2,8	3,9	7,3	11,8	19	30
V5	2,1	3,7	7	9,9	18,5	32,5	54,5
V6	1,3	2,6	4,5	6,7	10,8	16,5	37,3

The following values of J_1 moment of inertia are only estimated, referred to the maximum calculated, and to the gearbox input side.

BA-2/3	J_1 [Kg*m ²]
A42	0,0001
A52/A53	0,0001
A72/A73	0,0003

B	J_1 [Kg*m ²]
063	0,0001
083	0,0003
103	0,0007
123	0,0010
143	0,0023
153	0,0035
163	0,0093

3.1.1 BA.2

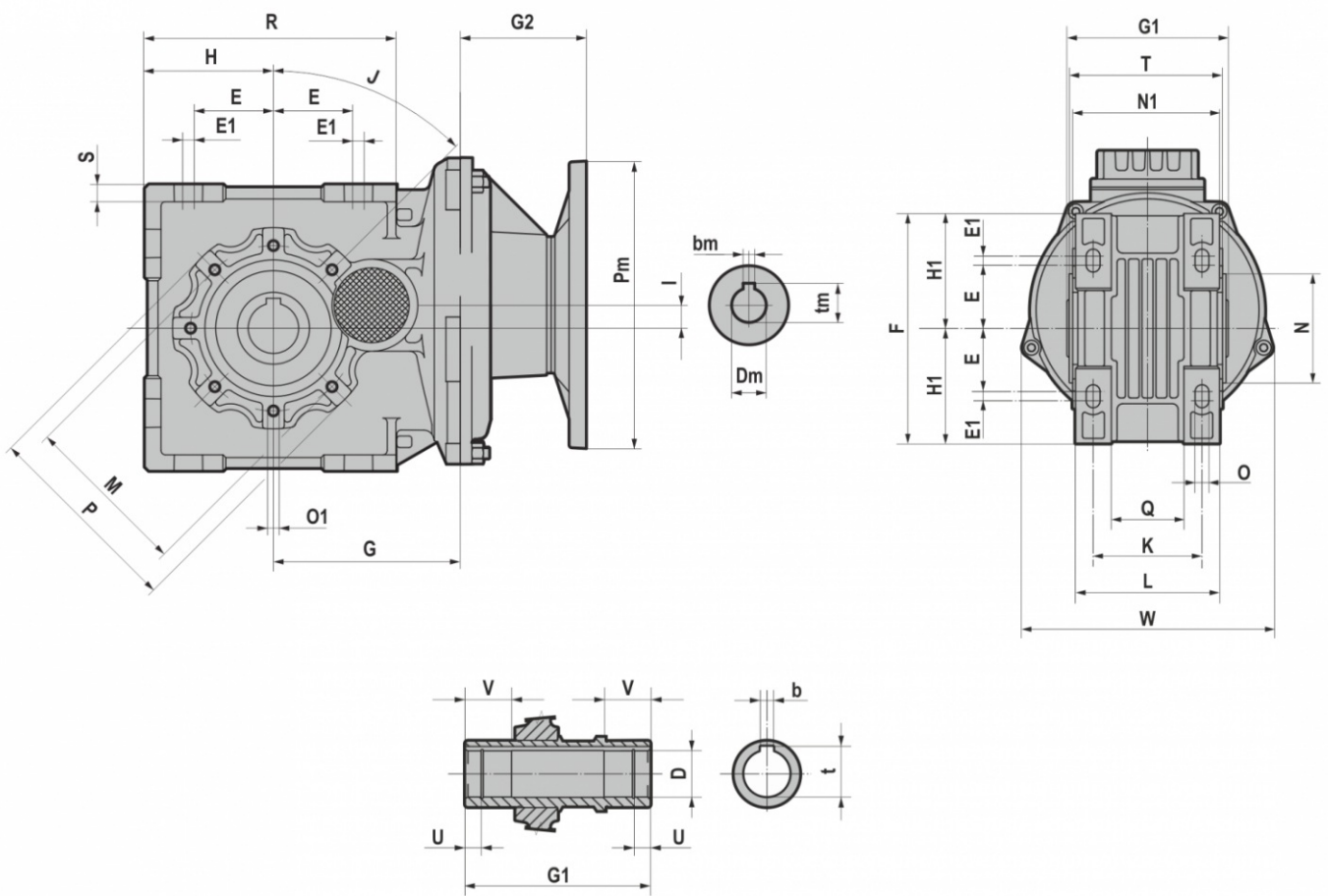

	DH7	b	t	U	V	E	E1	F	G	G1	H	H1	I	J	K	L	M	N	N1	O	O1	P	Q	R	S	T	W
BA42	20	6	22,8	/	30	45	/	130	95	100	65	65	8	45	73,5	90	85	70	92	9	M8x12 n.4	100	45	127,5	8	97	152
BA52	25	8	28,3	/	30	55	/	160	98	112	80	80	4,2	45	80	100	95	80	102	9	M8x14 n.6	110	51	153	10	108	152
	28	8	31,1	/	30	55	/	160	98	112	80	80	4,2	45	80	100	95	80	102	9	M8x14 n.6	110	51	153	10	108	152
BA72	35	10	38,3	12	35	55	8	200	129,5	140	90	100	16	45	94,5	125	115	95	130	12	M8x14 n.7	136	63	175	12	136	218
	30	8	33,3	12	35	55	8	200	129,5	140	90	100	16	45	94,5	125	115	95	130	12	M8x14 n.7	136	63	175	12	136	218

IEC	Pm x Dm		G2	
	Pm x Dm	Pm x Dm	BA42-BA52	BA72
063	140x11	090x11	55	/
071	160x14	105x14	55	/
080	200x19	120x19	86	87,5
090	200x24	140x24	86	87,5
100-112	250x28	160x28	/	87,5

B5	Pm	Dm	bm	tm
063	140	11	4	12,8
071	160	14	5	16,3
080	200	19	6	21,8
090	200	24	8	27,3
100	250	28	8	31,3
112	250	28	8	31,3

B14	Pm	Dm	bm	tm
071	105	14	5	16,3
080	120	19	6	21,8
090	140	24	8	27,3
100	160	28	8	31,3
112	160	28	8	31,3

3.1.2 BA.3

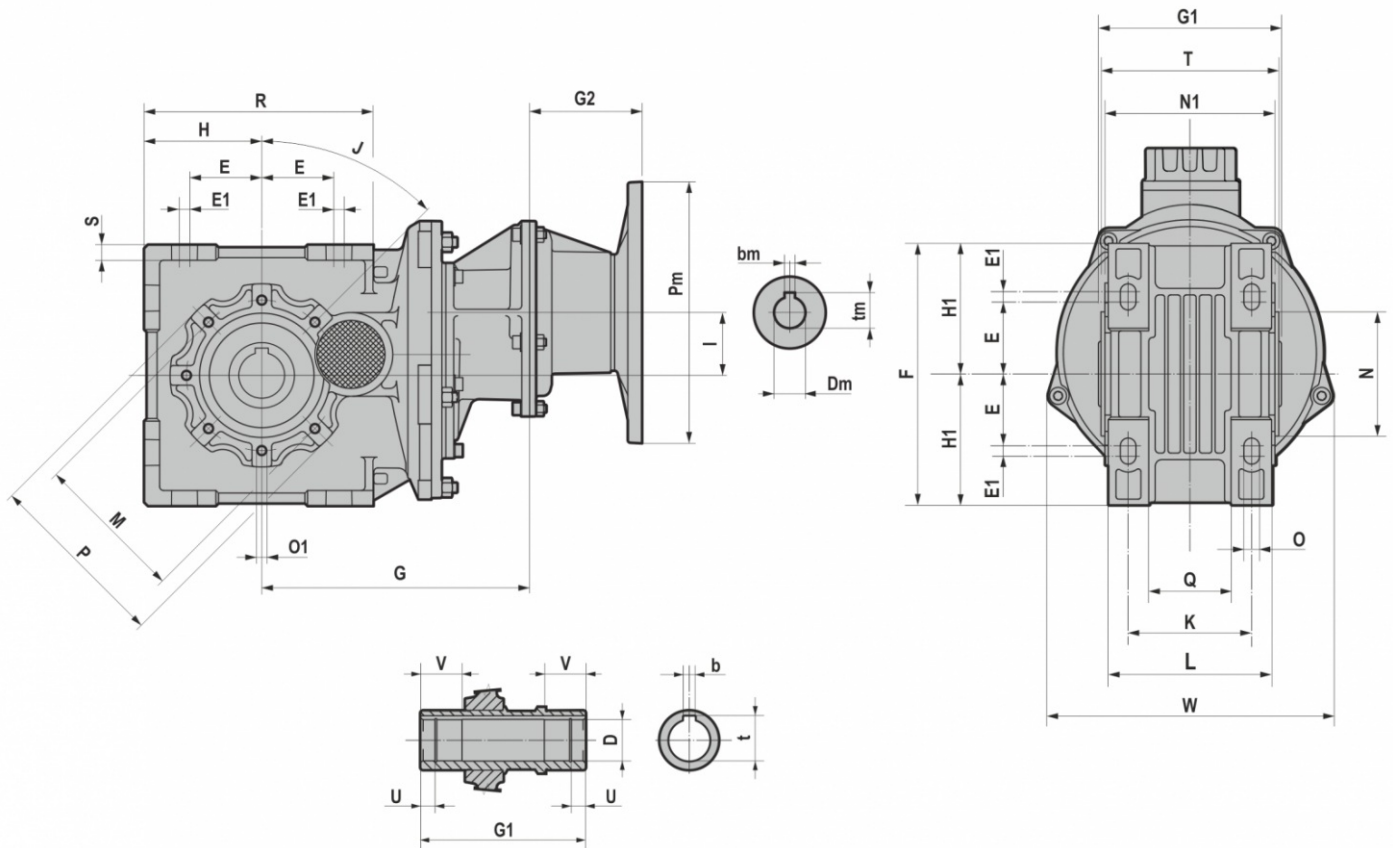

	DH7	b	t	U	V	E	E1	F	G	G1	H	H1	I	J	K	L	M	N	N1	O	O1	P	Q	R	S	T	W
BA53	25	8	28,3	/	30	55	/	160	162	112	80	80	36,2	45	80	100	95	80	102	9	M8x14 n.6	110	51	153	10	108	152
	28	8	31,1																								
BA73	35	10	38,3	12	35	55	8	200	204,5	140	90	100	48	45	94,5	125	115	95	130	12	M8x14 n.7	136	63	175	12	136	218
	30	8	33,3																								

IEC	Pm x Dm	Pm x Dm	G2
			BA53-BA73
063	140X11	090x11	55
071	160X14	105x14	55
080	200X19	120x19	86
090	200X24	140x24	86

B5	Pm	Dm	bm	tm
063	140	11	4	12,8
071	160	14	5	16,3
080	200	19	6	21,8
090	200	24	8	27,3

B14	Pm	Dm	bm	tm
071	105	14	5	16,3
080	120	19	6	21,8
090	140	24	8	27,3

3.1.3 CBA.2

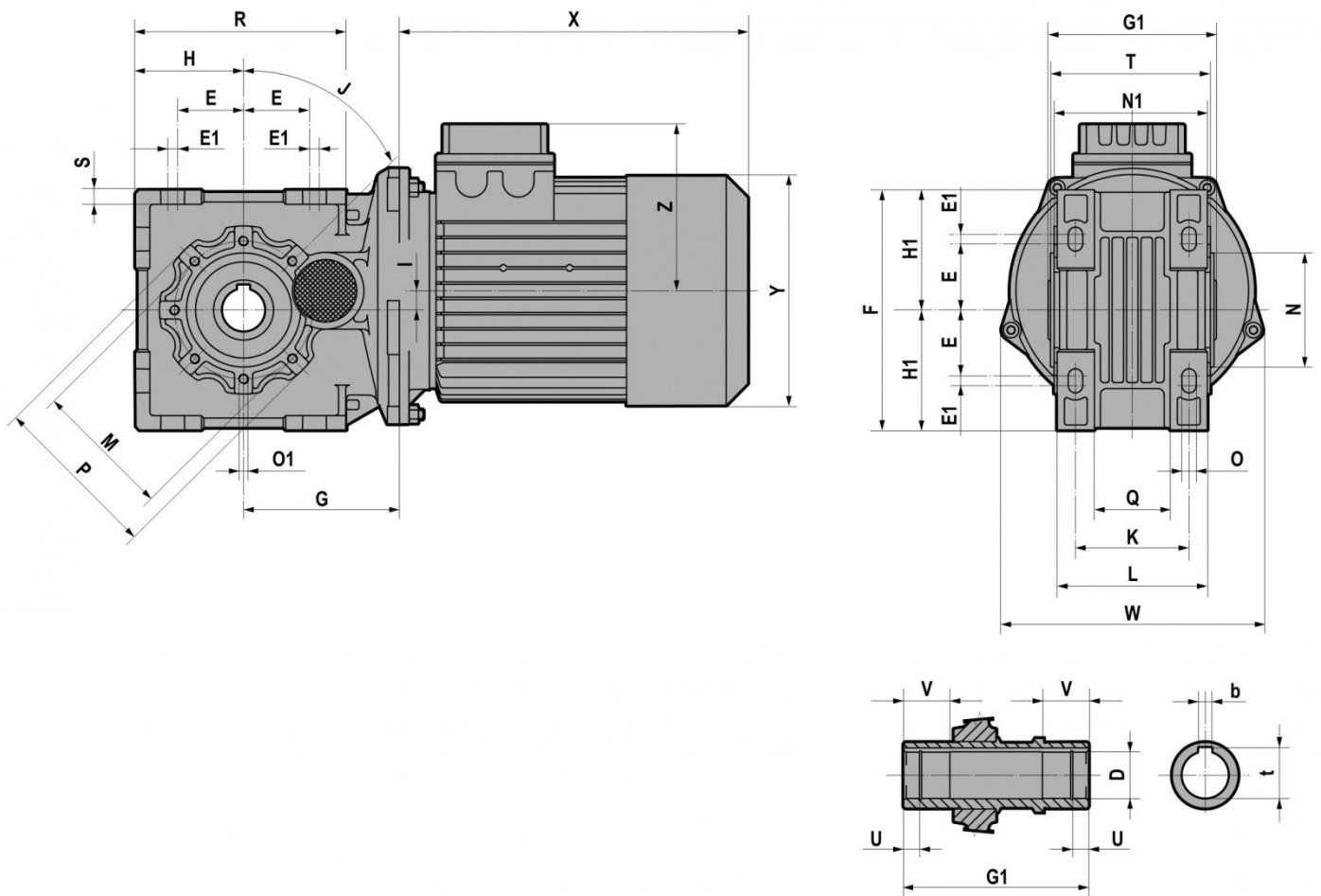

	D	H7	b	t	U	V	E	E1	F	G	G1	H	H1	I	J	K	L	M	N	N1	O	O1	P	Q	R	S	T	W
CBA42	20	6	22,8	/	30	45	/	130	95	100	65	65	8	45	73,5	90	85	70	92	9	M8x12 n.4	100	45	127,5	8	97	152	
	25	8	28,3	/	30	55	/	160	98	112	80	80	4,2	45	80	100	95	80	102	9	M8x14 n.6	110	51	153	10	108	152	
CBA52	28	8	31,1	/	30	55	/	160	98	112	80	80	4,2	45	80	100	95	80	102	9	M8x14 n.6	110	51	153	10	108	152	
	35	10	38,3	/	30	55	/	160	98	112	80	80	4,2	45	80	100	95	80	102	9	M8x14 n.6	110	51	153	10	108	152	
CBA72	30	8	33,3	12	35	55	8	200	129,5	140	90	100	16	45	94,5	125	115	95	130	12	M8x14 n.7	136	63	175	12	136	218	
	30	8	33,3	12	35	55	8	200	129,5	140	90	100	16	45	94,5	125	115	95	130	12	M8x14 n.7	136	63	175	12	136	218	

		T (IE1 - IE2)						
		O63	O71	O80	O90S	O90L	100	112
CBA42 CBA52	X	180	205	223	237	262	/	/
	Y	121	139	158	173	173	/	/
	Z	104	112	122	130	130	/	/
CBA72	X	/	/	218	232	257	290	302
	Y	/	/	158	173	173	191	211
	Z	/	/	122	130	130	139	154

		TB (IE1 - IE2)						
		O63	O71	O80	O90S	O90L	100	112
CBA42 CBA52	X	238	270,5	294	313	338	/	/
	Y	121	139	158	173	173	/	/
	Z	119	129	137	157	157	/	/
CBA72	X	/	/	290	309	334	372	400
	Y	/	/	158	173	173	191	211
	Z	/	/	137	157	157	168	183

3.1.4 CBA.3

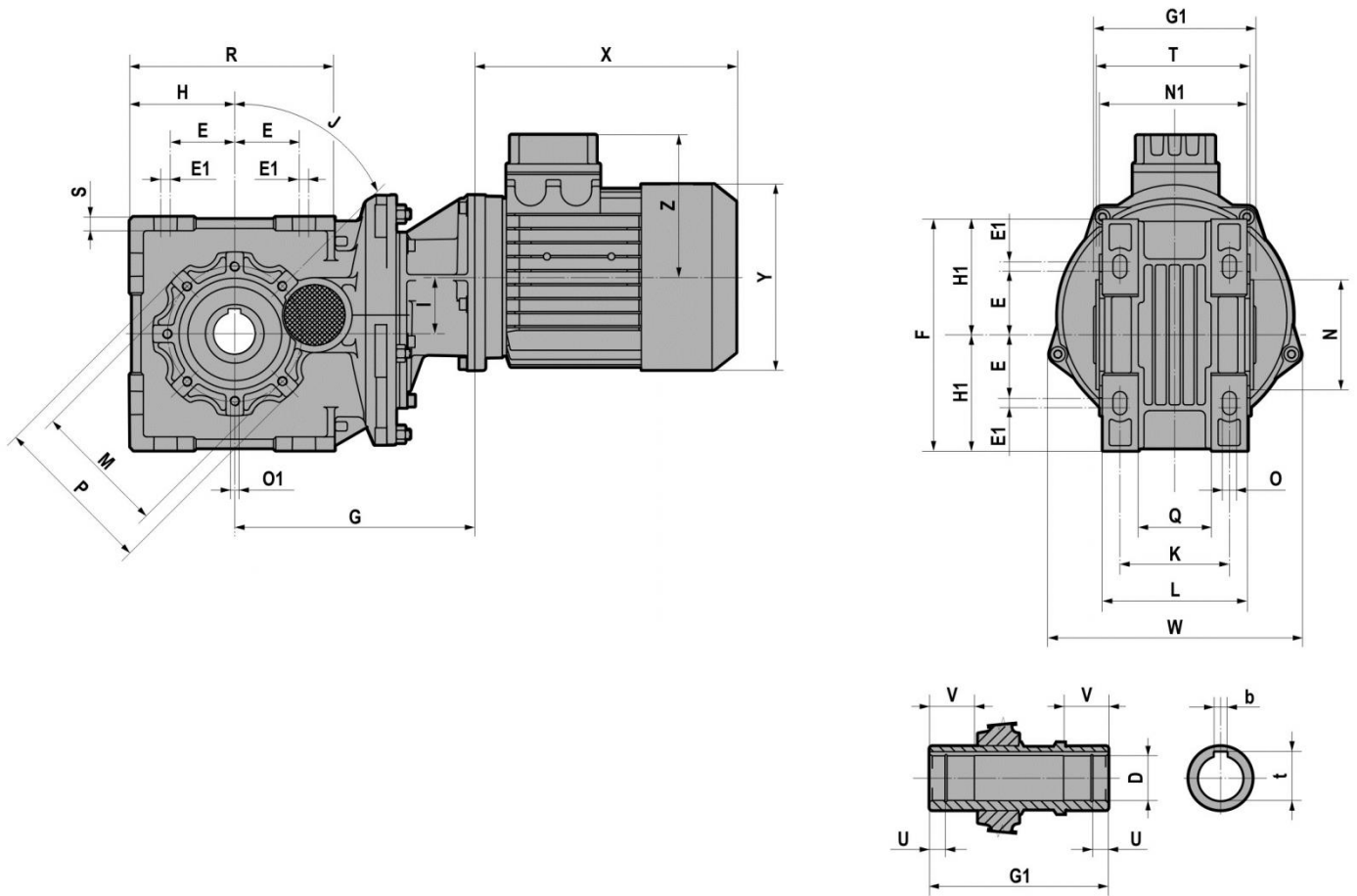

	DH7	b	t	U	V	E	E1	F	G	G1	H	H1	I	J	K	L	M	N	N1	O	O1	P	Q	R	S	T	W
CBA53	25	8	28,3	/	30	55	/	160	162	112	80	80	36,2	45	80	100	95	80	102	9	M8x14 n.6	110	51	153	10	108	152
	28	8	31,1																								
CBA73	35	10	38,3	12	35	55	8	200	204,5	140	90	100	48	45	94,5	125	115	95	130	12	M8x14 n.7	136	63	175	12	136	218
	30	8	33,3																								

		T (IE1 - IE2)				
		O63	O71	O80	O90S	O90L
CBA53 CBA73	X	180	205	223	237	262
	Y	121	139	158	173	173
	Z	104	112	122	130	130

		TB (IE1 - IE2)				
		O63	O71	O80	O90S	O90L
CBA53 CBA73	X	238	270,5	294	313	338
	Y	121	139	158	173	173
	Z	119	129	137	157	157

3.1.5 IBA.2

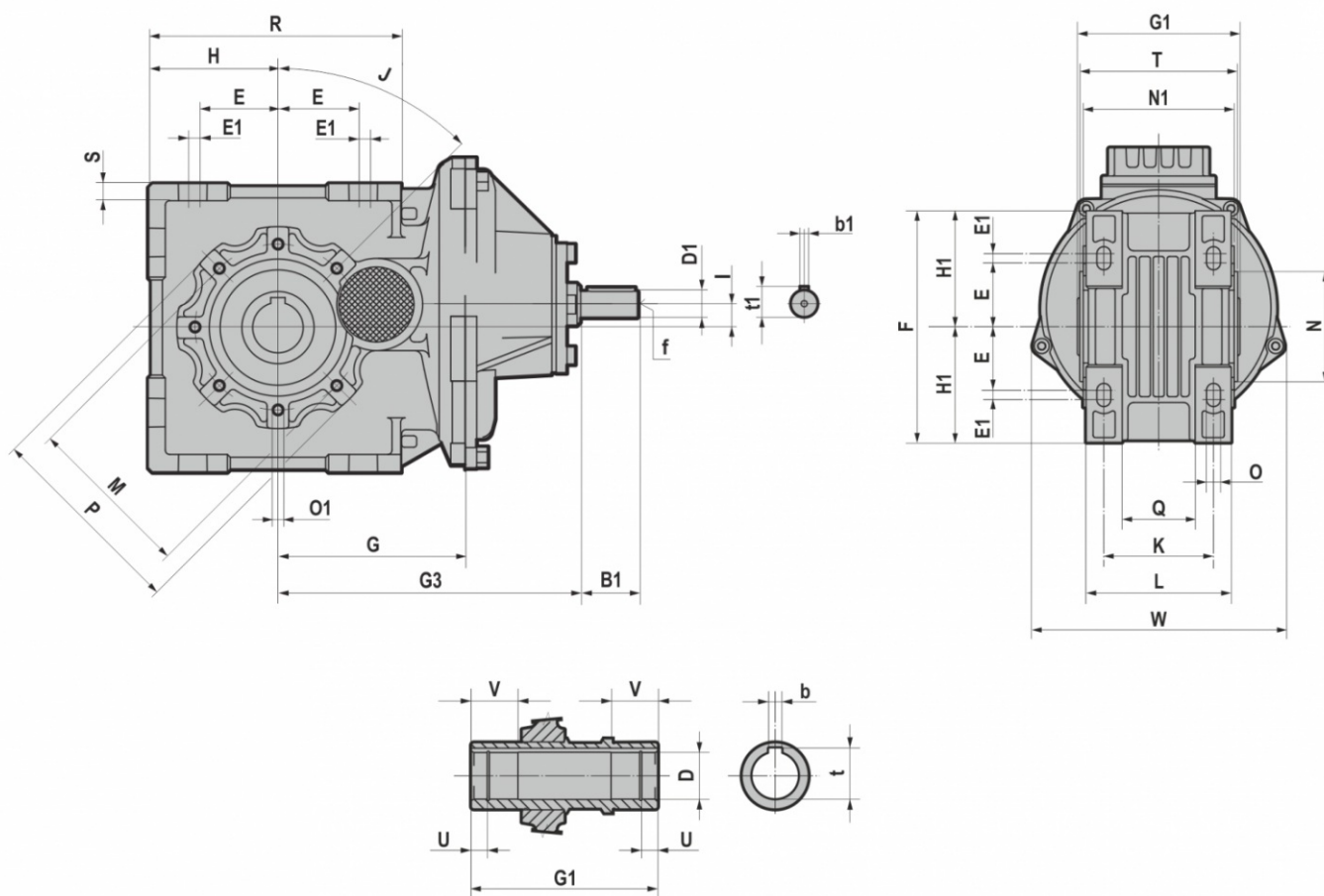

	DH7	b	t	U	V	E	E1	F	G	G1	H	H1	I	J	K	L	M	N	N1	O	O1	P	Q	R	S	T	W
IBA42	20	6	22,8	/	30	45	/	130	95	100	65	65	8	45	73,5	90	85	70	92	9	M8x12 n.4	100	45	127,5	8	97	152
IBA52	25	8	28,3	/	30	55	/	160	98	112	80	80	4,2	45	80	100	95	80	102	9	M8x14 n.6	110	51	153	10	108	152
	28	8	31,1	/	30	55	/	160	98	112	80	80	4,2	45	80	100	95	80	102	9	M8x14 n.6	110	51	153	10	108	152
IBA72	35	10	38,3	12	35	55	8	200	129,5	140	90	100	16	45	94,5	125	115	95	130	12	M8x14 n.7	136	63	175	12	136	218
	30	8	33,3	12	35	55	8	200	129,5	140	90	100	16	45	94,5	125	115	95	130	12	M8x14 n.7	136	63	175	12	136	218

	G3	D1	B1	b1	t1	f
IBA42	175,5	16	40	5	18	M6
IBA52	179	16	40	5	18	M6
IBA72	210	19	40	6	21,5	M6

3.1.6 IBA.3

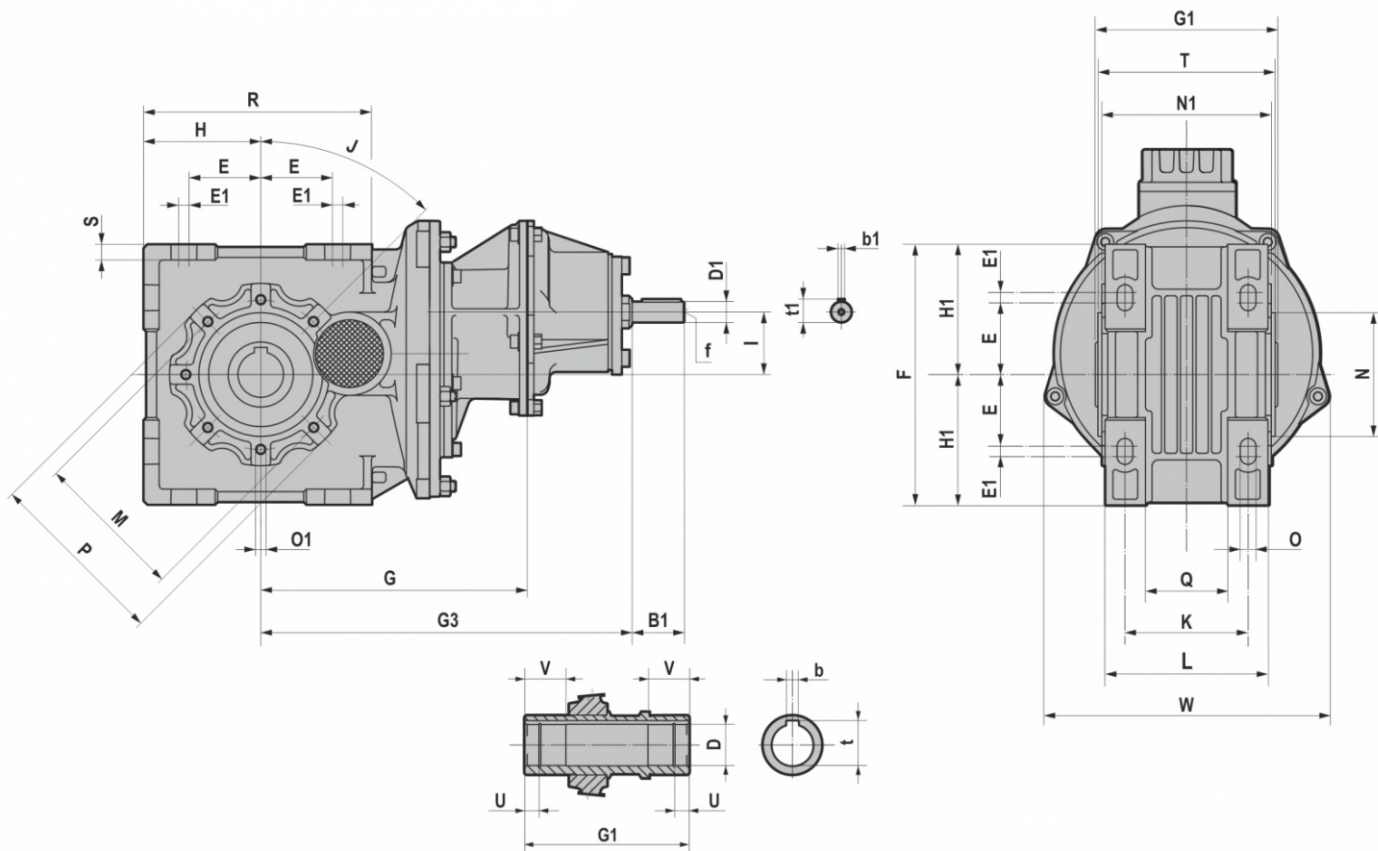

	D	H7	b	t	U	V	E	E1	F	G	G1	H	H1	I	J	K	L	M	N	N1	O	O1	P	Q	R	S	T	W
IBA53	25	8	28,3	/	30	55	/	160	162	112	80	80	36,2	45	80	100	95	80	102	9	M8x14 n.6	110	51	153	10	108	152	
	28	8	31,1																									
IBA73	35	10	38,3	12	35	55	8	200	204,5	140	90	100	48	45	94,5	125	115	95	130	12	M8x14 n.7	136	63	175	12	136	218	
	30	8	33,3																									

	G3	D1	B1	b1	t1	f
IBA53	242,5	16	40	5	18	M6
IBA73	285	16	40	5	18	M6

3.1.7 B

B...F

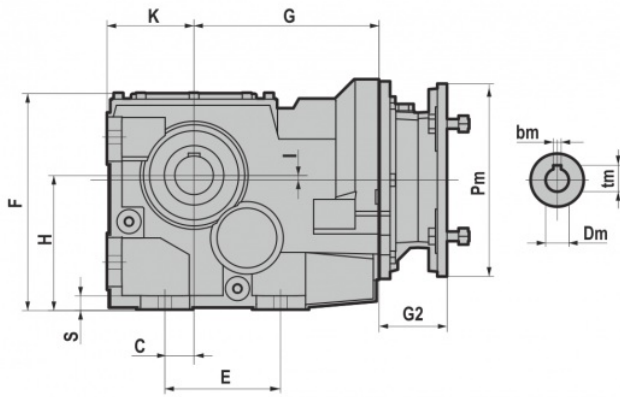

B...S

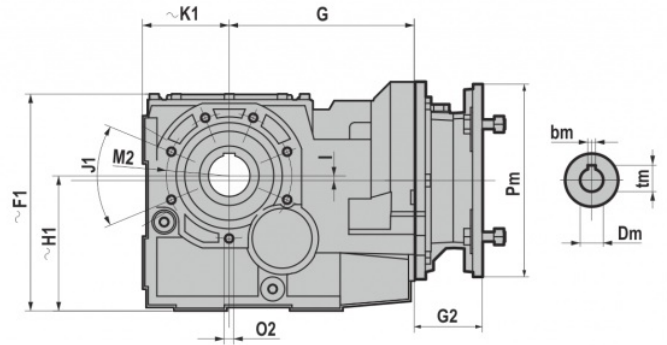

B...U

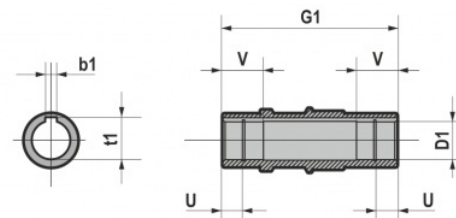
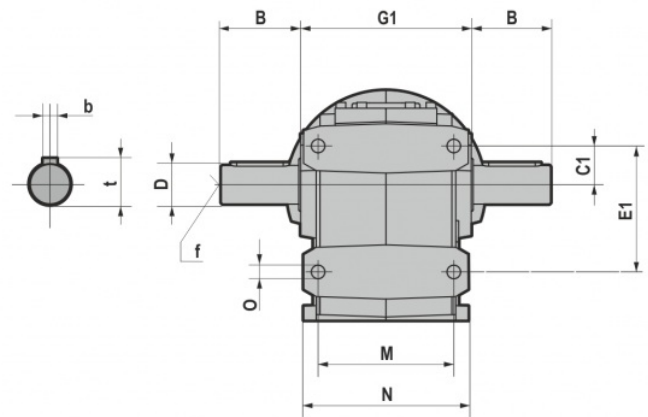
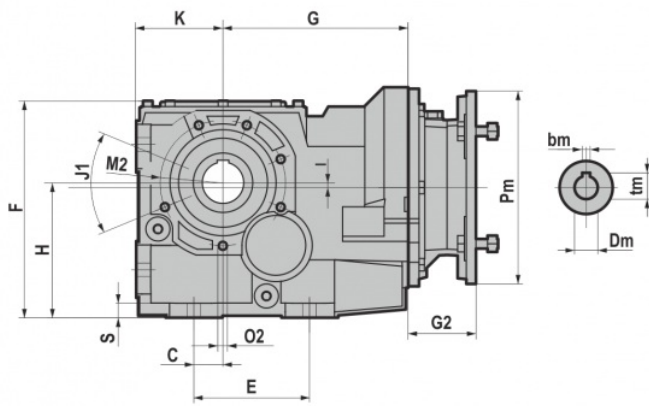

3.1 REDUCERS/GEARED MOTORS

	D1 H7	b1	t1	U	V	B	D	b	t	f	C	C1	E	E1	F	F1
B063	35	10	38,3	12	35	58	35 k6	10	38	M12	30	39	130	126	215	219,5
	40	12	43,3													
B083	40	12	43,3	22,25	42	80	40 k6	12	43	M16	30	40	120	130	225	225
	45	14	47,6													
B103	45	14	48,8	22,25	50	100	50 k6	14	53,5	M16	40	50	150	160	283	283
	50	14	53,8													
B123	60	18	64,4	28	70	120	60 m6	18	64	M20	55	78	180	220	341	342
B143	70	20	74,9	27,5	75	140	70 m6	20	74,5	M20	75	90	240	280	414	/
B153	90	25	95,4	34	90	170	90 m6	25	95	M20	95	110	280	330	490	/
	80	22	85,4													
B163	100	28	106,4	40	100	210	110 m6	28	116	M20	115	155	350	420	615	/

	G	G1	H	H1	I	K	K1	M	N	O	S	J1	M2	O2
B063	174	140	132	137	33	88	92,5	104	126	14	12	45	130	M10x20 (n.6)
B083	192	180	140	140	5	90	90	140	170	14	15	45	130	M10x20 (n.6/7)
B103	213,5	210	180	180	25	112	112	165	205	18	18	45	165	M12x22 (n.6/7)
B123	246	240	212	213	33,5	132	133	180	230	22	22	45	185	M14x28 (n.7)
B143	279	300	265	/	34	160	/	240	290	22	22	45	200	M14x30 (n.7)
B153	353	350	315	/	35	200	/	270	330	26	26	45	245	M16x32 (n.7)
B163	426,5	445	375	/	47	230,5	/	330	400	38	45	45	298	M18x40 (n.6)

IEC	Pm x Dm	G2				
		B063	B083-B103	B123-B143	B153	B163
063	140x11	57	/	/	/	/
071	160x14	69,0	/	/	/	/
080	200x19	90,0	70,0	60,5	/	/
090	200x24	90,0	70,0	60,5	/	/
100-112	250x28	105,0	85,0	75,5	/	/
132	300x38	/	110,0	100,5	76,0	/
160	350x42	/	157,5	148,0	123,5	109,0
180	350x48	/	157,5	148,0	123,5	109,0
200	400x55	/	/	185,0	160,5	146,0
225	450x60	/	/	/	160,5	146,0
250	550*65	/	/	/	/	175,0
280	550*75	/	/	/	/	175,0

B5	Pm	Dm	bm	tm
063	140	11	4	12,8
071	160	14	5	16,3
080	200	19	6	21,8
090	200	24	8	27,3
100	250	28	8	31,3
112	250	28	8	31,3
132	300	38	10	41,3
160	350	42	12	45,3
180	350	48	14	51,8
200	400	55	16	59,3
225	450	60	18	64,4
250	550	65	18	69,4
280	550	75	20	79,9

3.1.8 CB

CB...F

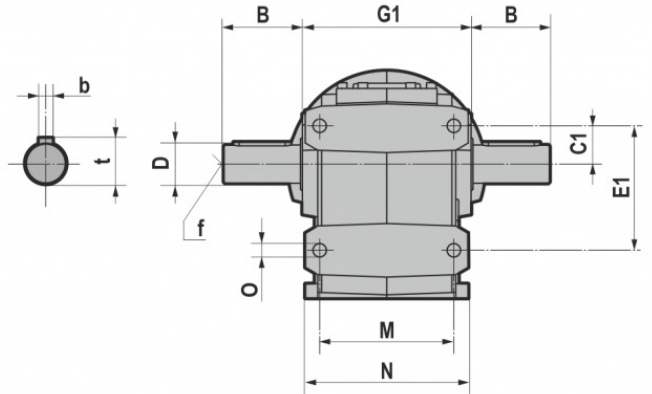
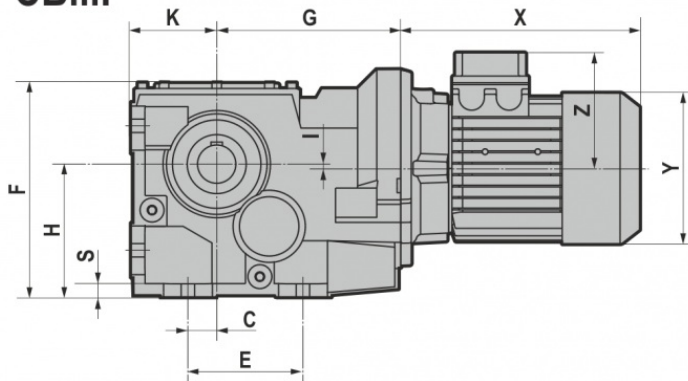

CB...S

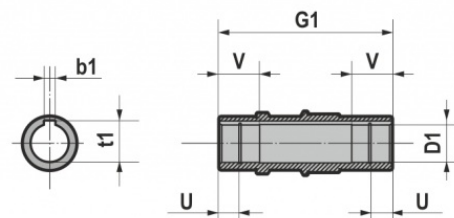
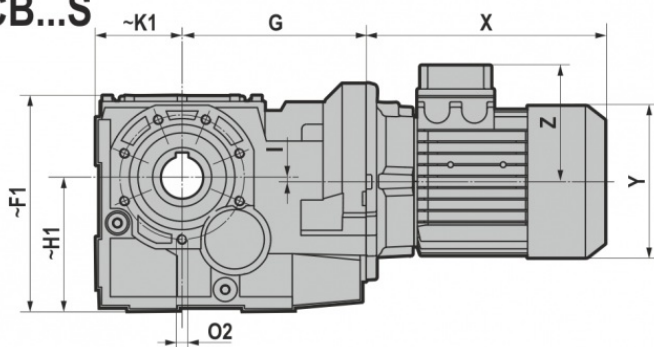

CB...U

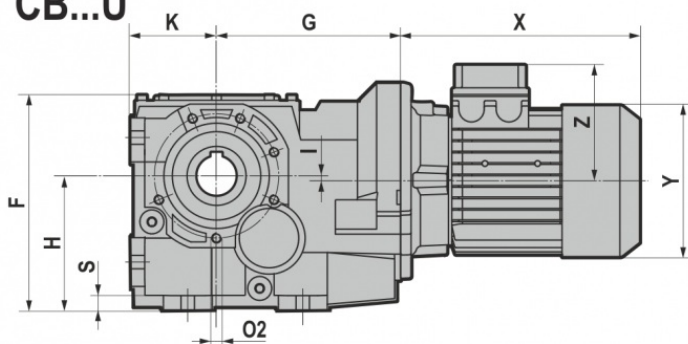

3.1 REDUCERS/GEARED MOTORS

	D1 H7	b1	t1	U	V	B	D	b	t	f	C	C1	E	E1	F	F1
CB063	35	10	38,3	12	35	58	35 k6	10	38	M12	30	39	130	126	215	219,5
	40	12	43,3													
CB083	40	12	43,3	22,25	42	80	40 k6	12	43	M16	30	40	120	130	225	225
	45	14	47,6													
CB103	45	14	48,8	22,25	50	100	50 k6	14	53,5	M16	40	50	150	160	283	283
	50	14	53,8													
CB123	60	18	64,4	28	70	120	60 m6	18	64	M20	55	78	180	220	341	342
CB143	70	20	74,9	27,5	75	140	70 m6	20	74,5	M20	75	90	240	280	414	/
CB153	90	25	95,4	34	90	170	90 m6	25	95	M20	95	110	280	330	490	/
	80	22	85,4													
CB163	100	28	106,4	40	100	210	110 m6	28	116	M20	115	155	350	420	615	/

	G	G1	H	H1	I	K	K1	M	N	O	S	J1	M2	O2
CB063	174	140	132	137	33	88	92,5	104	126	14	12	45	130	M10x20 (n.6)
CB083	192	180	140	140	5	90	90	140	170	14	15	45	130	M10x20 (n.6/7)
CB103	213,5	210	180	180	25	112	112	165	205	18	18	45	165	M12x22 (n.6/7)
CB123	246	240	212	213	33,5	132	133	180	230	22	22	45	185	M14x28 (n.7)
CB143	279	300	265	/	34	160	/	240	290	22	22	45	200	M14x30 (n.7)
CB153	353	350	315	/	35	200	/	270	330	26	26	45	245	M16x32 (n.7)
CB163	426,5	445	375	/	47	230,5	/	330	400	38	45	45	298	M18x40 (n.6)

		T (IE1 - IE2)								
		063	071	080	090S	090L	100	112	132S	132M
CB063	X	215	241	268	296	321	333	351	/	/
	Y	121	139	158	173	173	191	211	/	/
	Z	104	112	122	130	130	139	154	/	/
CB083 CB103	X	/	221	248	276	301	335	356	405	443
	Y	/	139	158	173	173	191	211	249	249
	Z	/	112	122	130	130	139	154	194	194
CB123 CB143	X	/	/	/	267	292	326	347	396	434
	Y	/	/	/	173	173	191	211	249	249
	Z	/	/	/	130	130	139	154	194	194

		TB (IE1 - IE2)								
		063	071	080	090S	090L	100	112	132S	132M
CB063	X	273	307	341	373	398	415	448	/	/
	Y	121	139	158	173	173	191	211	/	/
	Z	119	129	137	157	157	168	183	/	/
CB083 CB103	X	/	287	321	353	378	417	453	505	547
	Y	/	139	158	173	173	191	211	249	249
	Z	/	129	137	157	157	168	183	230	230
CB123 CB143	X	/	/	/	343	368	407	443	495	537
	Y	/	/	/	173	173	191	211	249	249
	Z	/	/	/	157	157	168	183	230	230

3.1.9 IB

IB...F

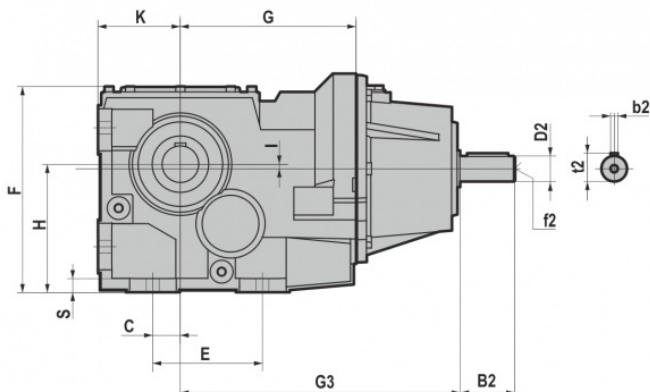

IB...S

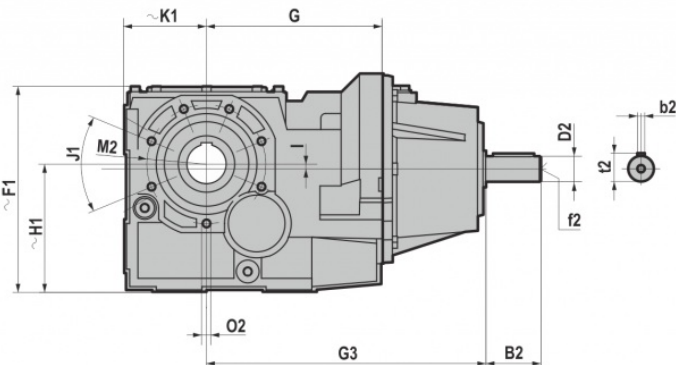

IB...U

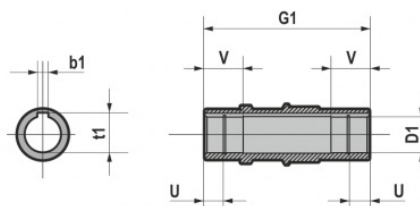
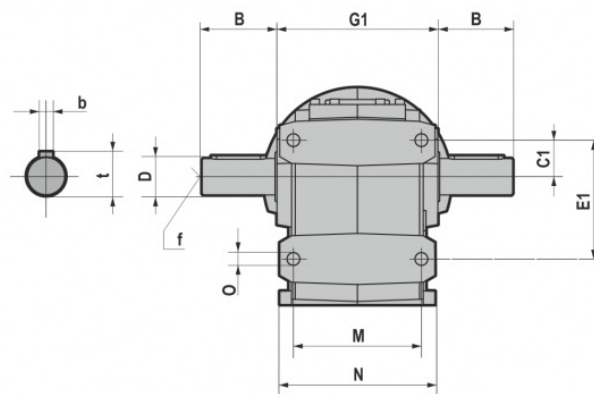
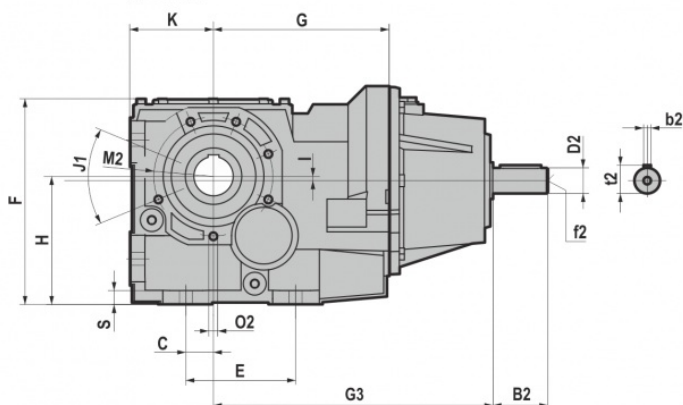

3.1 REDUCERS/GEARED MOTORS

	D1 H7	b1	t1	U	V	B	D	b	t	f	C	C1	E	E1	F	F1
IB063	35	10	38,3	12	35	58	35 k6	10	38	M12	30	39	130	126	215	219,5
	40	12	43,3													
IB083	40	12	43,3	22,25	42	80	40 k6	12	43	M16	30	40	120	130	225	225
	45	14	47,6													
IB103	45	14	48,8	22,25	50	100	50 k6	14	53,5	M16	40	50	150	160	283	283
	50	14	53,8													
IB123	60	18	64,4	28	70	120	60 m6	18	64	M20	55	78	180	220	341	342
IB143	70	20	74,9	27,5	75	140	70 m6	20	74,5	M20	75	90	240	280	414	/
IB153	90	25	95,4	34	90	170	90 m6	25	95	M20	95	110	280	330	490	/
	80	22	85,4													
IB163	100	28	106,4	40	100	210	110 m6	28	116	M20	115	155	350	420	615	/

	G	G1	H	H1	I	K	K1	M	N	O	S	J1	M2	O2
IB063	174	140	132	137	33	88	92,5	104	126	14	12	45	130	M10x20 (n.6)
IB083	192	180	140	140	5	90	90	140	170	14	15	45	130	M10x20 (n.6/7)
IB103	213,5	210	180	180	25	112	112	165	205	18	18	45	165	M12x22 (n.6/7)
IB123	246	240	212	213	33,5	132	133	180	230	22	22	45	185	M14x28 (n.7)
IB143	279	300	265	/	34	160	/	240	290	22	22	45	200	M14x30 (n.7)
IB153	353	350	315	/	35	200	/	270	330	26	26	45	245	M16x32 (n.7)
IB163	426,5	445	375	/	47	230,5	/	330	400	38	45	45	298	M18x40 (n.6)

	G3	B2	D2	b2	t2	f2
IB063	264	50	24 j6	8	27	M8
IB083	305	60	28 j6	8	31	M10
IB103	326,5	60	28 j6	8	31	M10
IB123	372,5	80	38 k6	10	41	M12
IB143	405,5	80	38 k6	10	41	M12
IB153	493	110	42 k6	12	45	M16
IB163	561,5	110	48 k6	14	51,5	M16

3.2.1 Electric motors

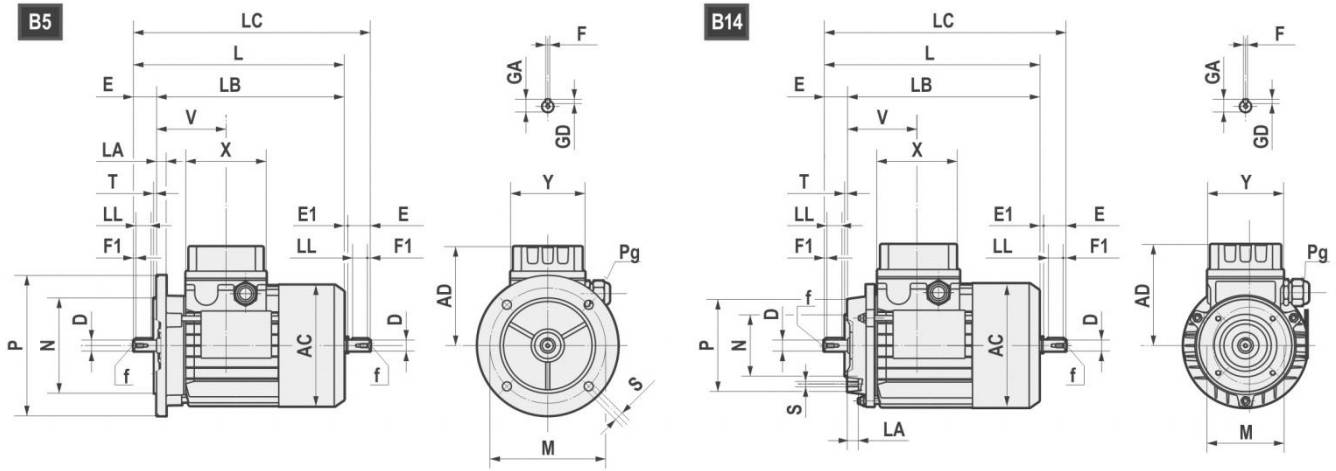

	AC	AD	L	LB	LC	X	Y	V	D	E	E1	f	F1	GA	F	GD
063	121	104	211	188	235,5	80	74	69	11 j6	23	1,5	M4x10	2,5	12,5	4	4
071	139	112	238,5	208,5	271	80	74	74,5	14 j6	30	2,5	M5x12,5	3	16	5	5
080	158	122	272,5 *(296)	232,5 *(256)	314 *(337)	80	74	78	19 j6	40	1,5	M6x16	5	21,5	6	6
90S	173	146	298 *(331)	248 *(281)	349,5 *(381)	98	98	89,5	24 j6	50	1,5	M8x19	5	27	8	7
90L	173	146	323 *(356)	273 *(306)	374,5 *(408)	98	98	89,5	24 j6	50	1,5	M8x19	5	27	8	7
100	191	155	368	308	431,5	98	98	97,5	28 j6	60	3,5	M10x22	7,5	31	8	7
112	211	170	382,5 *(408)	322,5 *(348)	447 *(472)	98	98	100	28 j6	60	3,5	M10x22	7,5	31	8	7
132S	249	195	452	372	536,5	118	118	115,5	38 k6	80	4	M12x28	10	41	10	8
132L	249	195	490	410	574,5	118	118	115,5	38 k6	80	4	M12x28	10	41	10	8
160S	249	195	520	410	/	118	118	115,5	42k6	100	/	M16x36	10	45	12	8

*TP80B4, TP90S4, TP90L4, TP90S6, TP112M4, TP112M6

B5	M	N	P	LA	S	T
063	115	95	140	10	9	3
071	130	110	160	10	9,5	3,5
080	165	130	200	12	11	3,5
090	165	130	200	12	11	3,5
100	215	180	250	15	14	4
112	215	180	250	14,5	14	4
132	265	230	300	20	14	3,5
160	300	250	350	13	18,5	3,5

B14	M	N	P	LA	S	T
063	75	60	90	10	M5	2,5
071	85	70	105	10,5	M6	2,5
080	100	80	120	10,5	M6	3
090	115	95	140	11,5	M8	3
100	130	110	160	15	M8	3,5
112	130	110	160	11,5	M8	3,5
132	165	130	200	20,5	M10	3,5
160	215	180	250	-	M12	4

3.2 ELECTRIC MOTORS

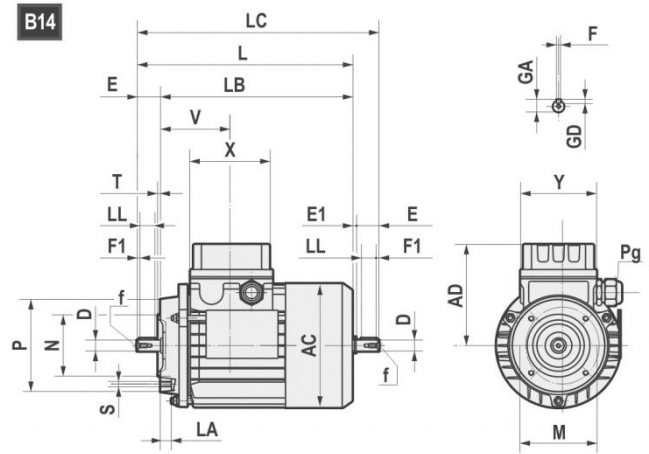
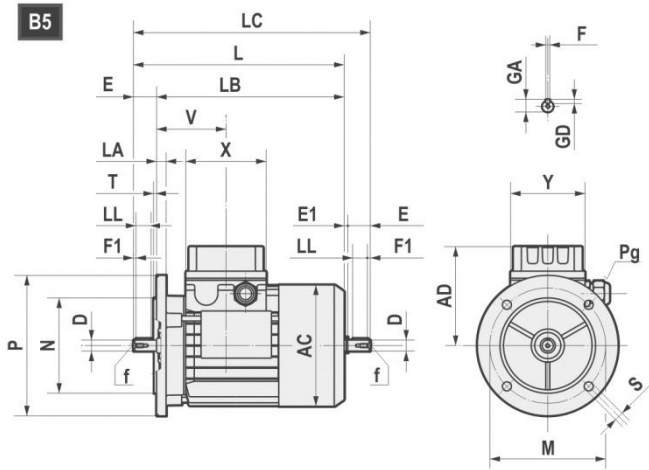

		AC	AD	L	LB	X	D	E	f	GA	F	GD	LL	Pg	
160M	4-6	314	251	600	490	158	42	110	M16	45	12	8	90	2-M40x1,5	1-M16x1,5
160L	4-6	314	251	645	535	158	42	110	M16	45	12	8	90	2-M40x1,5	1-M16x1,5
180M	4	355	267	680	570	158	48	110	M16	51,5	14	9	100	2-M40x1,5	1-M16x1,5
180L	6	355	267	720	610	158	48	110	M16	51,5	14	9	100	2-M40x1,5	1-M16x1,5
200L	4-6	397	300	785	675	187	55	110	M20	59	16	10	100	2-M50x1,5	1-M16x1,5
225S	4	446	325	820	680	187	60	140	M20	64	18	11	125	2-M50x1,5	1-M16x1,5
225M	4-6	446	325	845	705	187	60	140	M20	64	18	11	125	2-M50x1,5	1-M16x1,5
250M	4-6	485	360	910	770	238	60	140	M20	64	18	11	125	2-M63x1,5	1-M16x1,5
250M	4-6	485	360	910	770	238	65	140	M20	69	18	11	125	2-M63x1,5	1-M16x1,5
280S	4-6	547	390	970	830	238	65	140	M20	69	18	11	125	2-M63x1,5	1-M16x1,5
280S	4-6	547	390	970	830	238	75	140	M20	79,5	20	12	125	2-M63x1,5	1-M16x1,5
280M	4-6	547	390	1025	885	238	65	140	M20	69	18	11	125	2-M63x1,5	1-M16x1,5
280M	4-6	547	390	1025	885	238	75	140	M20	79,5	20	12	125	2-M63x1,5	1-M16x1,5

B5	M	N	P	LA	S	T
160	300	250	350	13	19	5
180	300	250	350	15	19	5
200	350	300	400	17	19	5
225	400	350	450	20	19	5
250	500	450	550	22	19	5
280	500	450	550	22	19	5

3.2.2 Standard high efficiency (TS), high (TH) and premium- (TP) motors

Motovario, three-phase, single polarity motors are available in three different versions (IE1-IE2-IE3) in compliance with standard 60034-30-1 (see table). The efficiency value is calculated according to the method set forth in standard IEC 60034-2-1.

1. IE1: Standard efficiency TS series.
2. IE2: High efficiency TH series
3. IE3: Premium efficiency TP series.

Table of Motovario commercial availability

NOMINAL POWER [kW]	POLES	EFFICIENCY LEVEL		
		IE1	IE2	IE3
$0,09 \leq P_n < 0,75$	4 - 6	TS-TBS	-	-
$0,75 \leq P_n \leq 11$	4	TBS	-	-
$0,75 \leq P_n \leq 5,5$	6	TBS	TH-TBH	TP-TBP
$0,75 \leq P_n \leq 9,2$	4	-	TH-TBH	-
$0,75 \leq P_n \leq 7,5$	4	-	-	TP-TBP
$7,5 \leq P_n \leq 22$	6	TBS (*)	-	TP
$11 \leq P_n \leq 90$	4	-	-	TP
$15 \leq P_n \leq 55$	4	TBS (*)	-	-

(*) Series available on request.

3.2 ELECTRIC MOTORS

3.2.3 Nominal power - [kW]

	63A	63B	63C	71A	71B	71C	80A			80B		
Poles	TS	TS	TS	TS	TS	TS	TS	TH	TP	TS	TH	TP
4	0,12	0,18	0,22	0,25	0,37	0,55	0,55	-	-	-	0,75	0,75
6	0,09	0,12	0,15	0,18	0,25	0,37	0,37	-	-	0,55	-	-

	90S		90L		100LR	100L	100LA		112MR	112MS	112MA	112M
Poles	TH	TP	TH	TP	TP	TP	TH	TP	TP	TP	TH	TP
4	1,1	1,1	1,5	1,5	-	-	2,2	2,2	2,2	3	4	4
6	-	0,75	0,75	-	1,1	1,5	1,1	-	-	-	2,2	2,2

	112MR	112MS	132S	132SA	132MS	132SB	132M	132MA		132MB	
Poles	TP	TP	TP	TH	TP	TH	TP	TH	TP	TH	TP
4	2,2	3	-	5,5	5,5	-	7,5	7,5	-	9,2	-
6	-	-	3	3	-	-	-	4	4	5,5	5,5

	160M	160MA	160MB	160L	160LA	180M	180L
Poles	TP	TP	TP	TP	TP	TP	TP
4	-	11	-	-	15	18,5	22
6	7,5	-	-	11	-	-	15

	200L	200LA	200LB	225S	225M	250M	280S	280M
Poles	TP	TP	TP	TP	TP	TP	TP	TP
4	30	-	-	37	45	55	75	90
6	-	18,5	22	-	-	-	-	-

3.3 WEIGHT

The values reported in the tables are referred to the weight of the gearbox with lubricant excluded.

* B-PB	063	071	080-090	100-112	132	160-180	200	225	250	280		IB	- kg
A42	4,8	4,9	5,1	/	/	/	/	/	/	/	- kg	A42	4,8
A52	5,4	5,5	5,7	/	/	/	/	/	/	/		A52	5,4
A53	7,0	7,1	8,5	/	/	/	/	/	/	/		A53	8,2
A72	/	/	15,3	15,5	/	/	/	/	/	/		A72	15,4
A73	14,2	14,3	15,7	/	/	/	/	/	/	/		A73	15,4
063	20,6	21	21,6	25,9	/	/	/	/	/	/		063	23,7
083	/	/	29,3	31,3	33,8	/	/	/	/	/		083	33,1
103	/	/	54,8	56,8	59,5	66,2	/	/	/	/		103	58,8
123	/	/	76,6	79	81,7	87,7	/	/	/	/		123	86,5
143	/	/	/	124	127	133	148	/	/	/		143	132
153	/	/	/	/	199	206,5	221	223	/	/		153	213
163	/	/	/	/	/	385,3	449,8	457,1	473,5	473,5		163	455,6

*Weight without motor

CB	TS									- kg
	063	071	080	090S	090L	100	112	132S	132M	
A42	7,4	9,3	13,3	/	/	/	/	/	/	- kg
A52	8,2	10,2	14,2	16,1	18,6	/	/	/	/	
A53	9,7	11,7	15,7	17,6	20,1	/	/	/	/	
A72	/	/	21,6	23,6	26,1	34,6	41,6	/	/	
A73	16,9	18,9	22,9	24,9	27,4	/	/	/	/	
063	24,1	25	29,7	33,6	35,6	41,1	52,6	/	/	
083	/	/	35,7	38,1	39,6	44,7	56,1	70,1	81,7	
103	/	/	61,4	63,8	65,3	70,4	81,8	95,8	107,4	
123	/	/	/	85,7	86,7	92,7	102,7	117,7	126,7	
143	/	/	/	/	/	138	148	163	172	

CB	TH							- kg
	080	090S	090L	100	112	132S	132M	
A42	15,0	/	/	/	/	/	/	- kg
A52	15,9	18,4	20,6	/	/	/	/	
A53	17,4	19,9	22,1	/	/	/	/	
A72	23,3	25,9	28,1	36,9	44,7	/	/	
A73	24,6	27,2	29,4	/	/	/	/	
063	31,4	35,9	37,6	43,4	55,7	/	/	
083	37,4	40,4	41,6	47,0	59,2	75,4	88,5	
103	63,1	66,1	67,3	72,7	84,9	101,1	114,2	
123	/	88,0	88,7	95,0	105,8	123,0	133,5	
143	/	/	/	140,3	151,1	168,3	178,8	

CB	TBS									- kg
	063	071	080	090S	090L	100	112	132S	132M	
A42	8,8	11,3	16,4	/	/	/	/	/	/	- kg
A52	9,6	12,1	17,3	20,9	13,5	/	/	/	/	
A53	11,1	13,6	18,8	22,4	25	/	/	/	/	
A72	/	/	25,6	27,1	31,6	41,6	51,6	/	/	
A73	18,4	20,9	26,9	28,9	32,9	/	/	/	/	
063	25,6	27,2	33,2	39,1	41,1	46,6	62,3	/	/	
083	/	/	39,2	43,6	45,1	50,2	65,8	80,3	96,3	
103	/	/	64,8	69,3	70,8	75,8	91,5	106,1	122,1	
123	/	/	/	91,2	92,2	98,2	112,4	128	141,4	
143	/	/	/	/	/	143,5	158	173	187	

CB	TBH							- kg
	080	090S	090L	100	112	132S	132M	
A42	18,1	/	/	/	/	/	/	- kg
A52	19,0	23,2	15,5	/	/	/	/	
A53	20,5	24,7	27,0	/	/	/	/	
A72	27,3	29,4	33,6	45,3	54,7	/	/	
A73	28,6	31,2	34,9	/	/	/	/	
063	34,9	41,4	43,1	50,3	65,4	/	/	
083	40,9	45,9	47,1	53,9	68,9	85,6	102,8	
103	66,5	71,6	72,8	79,5	94,6	111,4	128,6	
123	/	93,5	94,2	101,9	115,5	133,3	147,9	
143	/	/	/	147,2	161,1	178,3	193,5	

3.4 END SHAFT

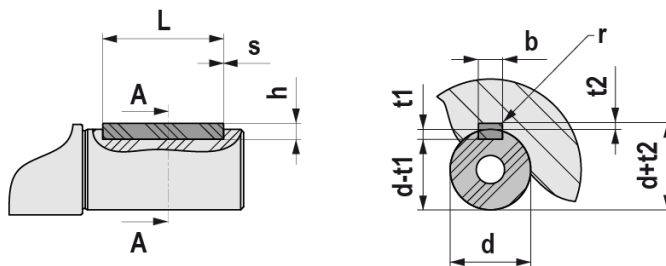

UNI 6604 - DIN 6885														
d		b x h		Tol. b/h	L		s min / max		b	t1	t2	Tol. t1/t2	r max	
	6	8	2	x	2	h9 / h9	6	20	0,16 0,25	2	1,2	1	0,1 0	0,08 0,16
>	8	10	3	x	3		6	36		3	1,8	1,4		
>	10	12	4	x	4		8	45		4	2,5	1,8		
>	12	17	5	x	5		10	56	5	3	2,3	0,25 0,4	0,16 0,25	
>	17	22	6	x	6		14	70	6	3	2,8			
>	22	30	8	x	7		18	90	8	4	3,3			
>	30	38	10	x	8	22	110	10	5	3,3	0,2 0	0,25 0,4		
>	38	44	12	x	8	28	140	12	5	3,3				
>	44	50	14	x	9	36	160	14	5,5	3,8				
>	50	58	16	x	10	45	180	16	6	4,3				
>	58	65	18	x	11	50	200	18	7	4,4				
>	65	75	20	x	12	56	110	20	7,5	4,9			0,6 0,8	0,4 0,6
>	75	85	22	x	14	63	140	22	9	5,4				
>	85	95	25	x	14	70	160	25	9	5,4				
>	95	110	28	x	16	80	180	28	10	6,4				
>	110	130	32	x	18	90	200	32	11	7,4				
>	130	150	36	x	20	100	160	36	12	8,4	1 1,2	0,7 1		
>	150	170	40	x	22	110	180	40	13	9,4				
>	170	200	45	x	25	125	200	45	14	10,4				

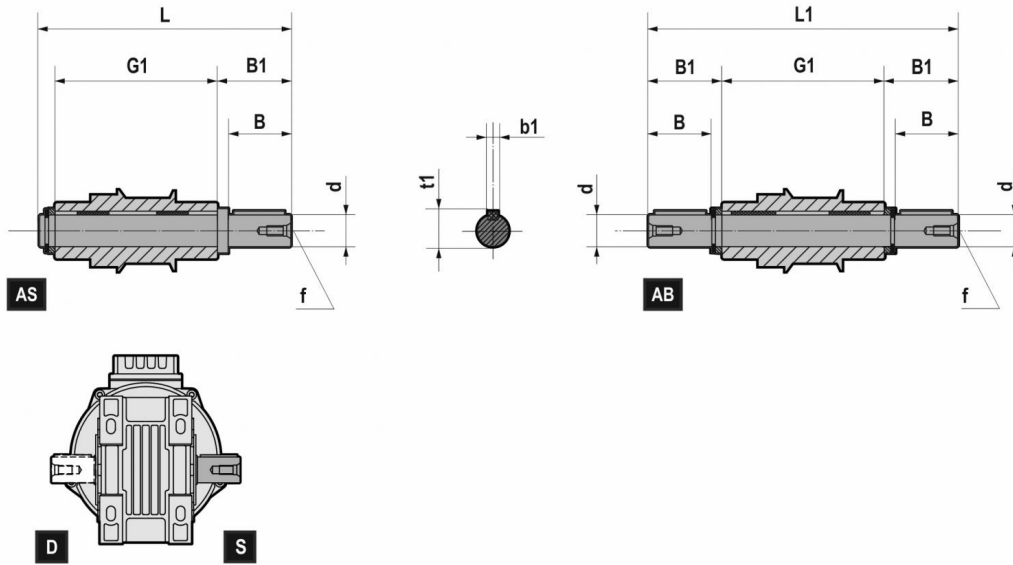

BA70 solid shaft

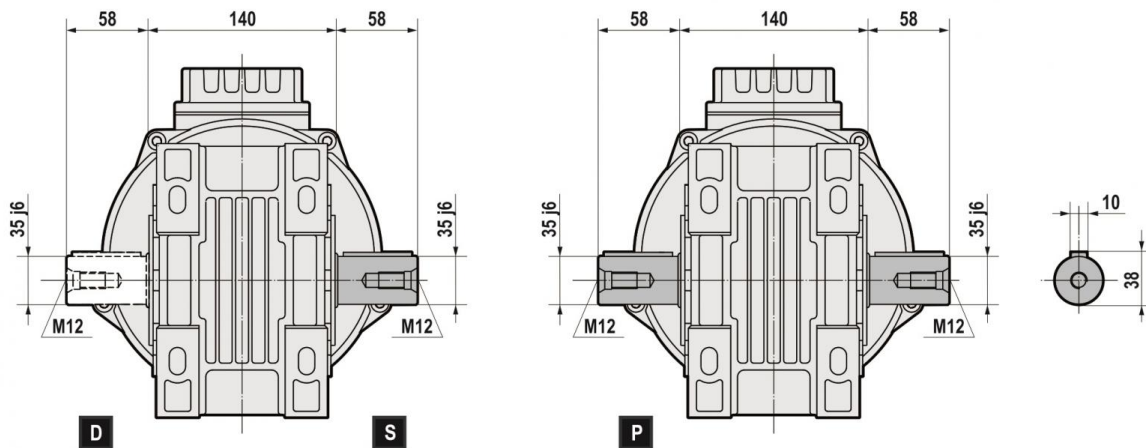

	d h6	B	B1	G1	L	L1	f	b1	t1
BA42	20	40	43,5	100	151	187	M6	6	22,5
BA52-BA53	25	50	53,5	112	173	219	M10	8	28
B063	35	58	62	140	210,5	264	M12	10	38
B083	40	80	84,25	180	273	348,5	M16	12	43
B103	50	100	105	210	325	420	M16	14	53,5
B123	60	120	125	240	375	490	M20	18	64
B143	70	140	146	300	458	592	M20	20	74,5
B153	90	170	176,5	350	540	703	M20	25	95
B163	100	210	217,5	445	677	880	M20	28	106

4.2.1 BA

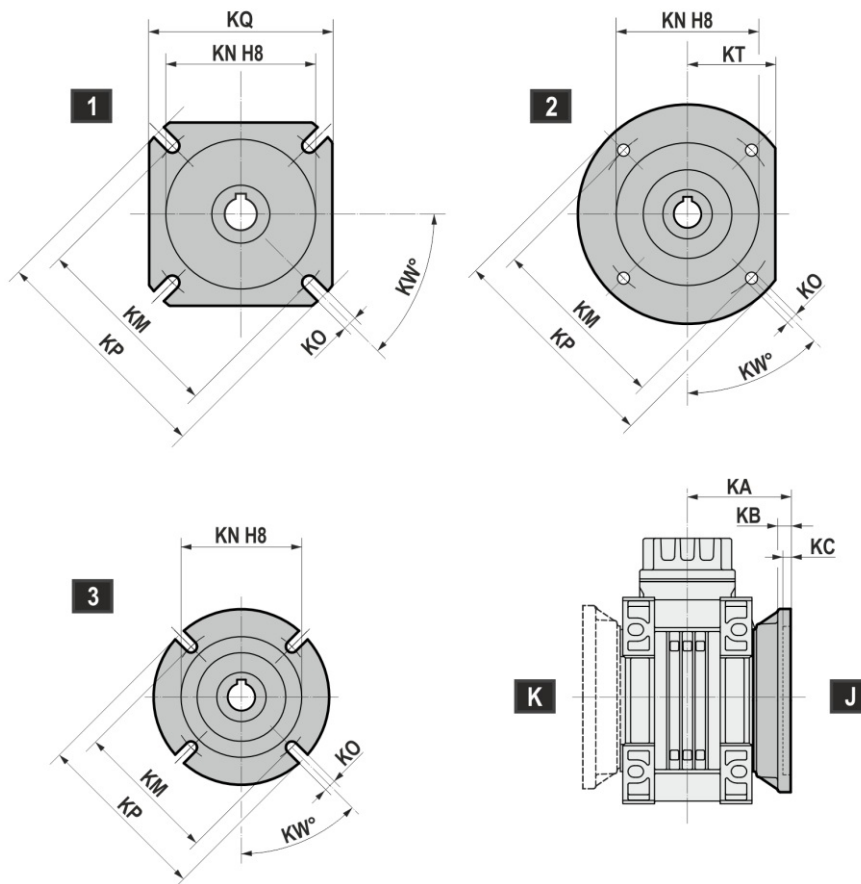

	A42	A52-A53	A72-A73
FA	1	1	1
FB	1	1	3
FC	2	2	-
FD	2	2	-

B.-CB..	KA	KB	KC	KN	KM	KO	KP	KQ	KT	KW	
BA42	FA	92,5	9	5	70	90 min	11 (n°4)	125	110	-	45°
	FB	122,5	9	5	70	90 min	11 (n°4)	125	110	-	45°
	FC	91,5	10	5	110	130	9.5 (n°4)	160	-	66	45°
	FD	74,5	14,5	5	95	115	11 (n°4)	140	-	60	45°
BA52 BA53	FA	80	10	6	115	150	11 (n°4)	180	142	-	45°
	FB	110	10	6	115	150	11 (n°4)	180	142	-	45°
	FC	96	10	5	130	165	11 (n°4)	200	-	80	45°
	FD	105	10	5	130	165	11 (n°4)	200	-	-	45°
BA72 BA73	FA	119	13	6	130	165	14 (n°4)	200	170	-	45°
	FB	98	13	6	110	130	11 (n°4)	160	-	-	45°

Unless specified otherwise, the reduction unit is supplied with the accessories in pos. J referred to position B3/B5.

4.2 OUTPUT FLANGE

4.2.2 B

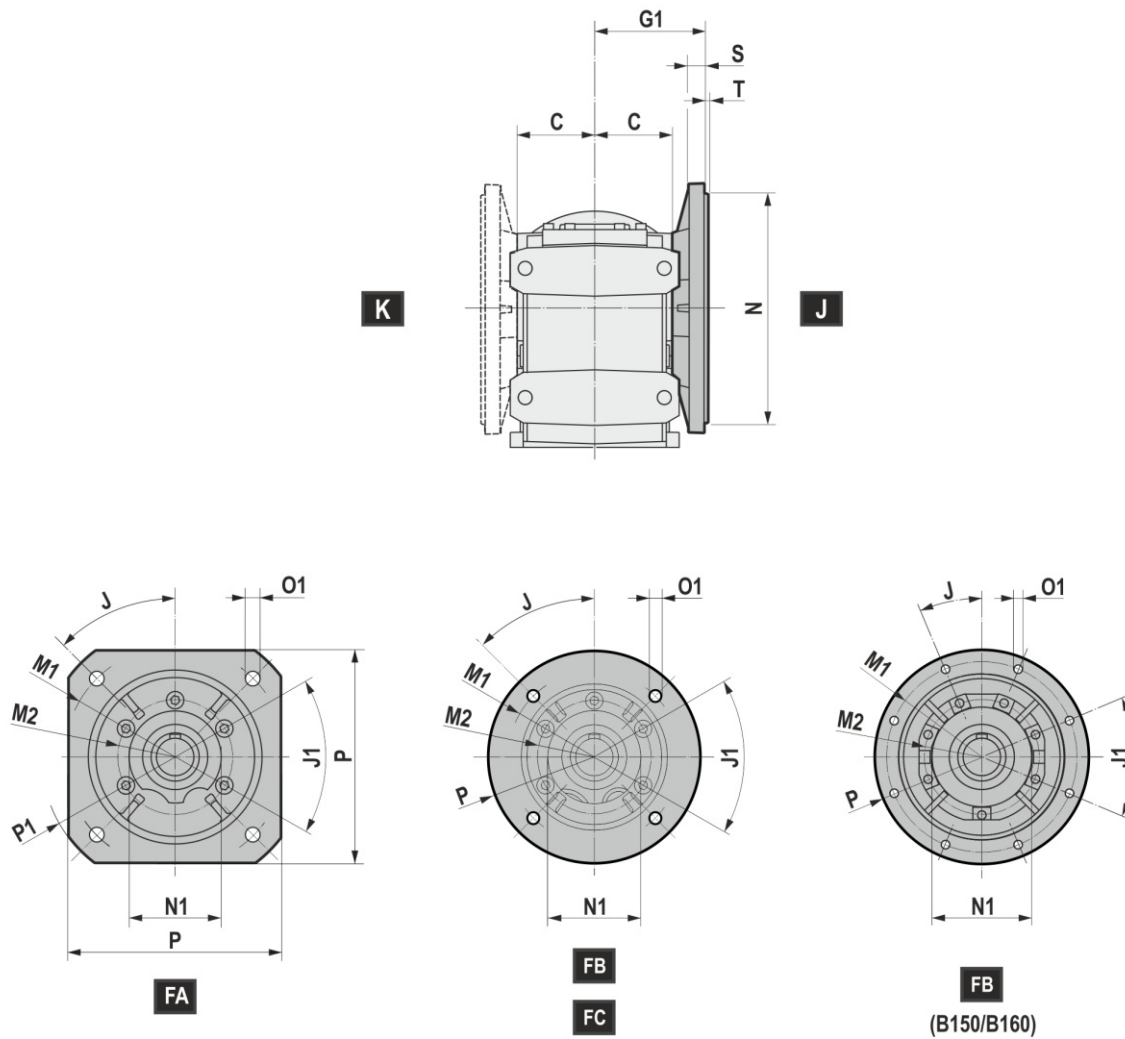

B..S - B..U		J	J1	M1	M2	N f8	N1	O1	P	P1	S	T	C	G1
B063	FA	45	45	265	130	230	110	14	250	300	15	4	61,5	93,5
	FB	45	45	215	130	180	110	14	250	/	15	4		
	FC	45	45	165	130	130	110	11	200	/	15	3,5		
B083	FA	45	45	265	130	230	110	14	250	300	15	4	78	110
	FB	45	45	215	130	180	110	14	250	/	15	4		
	FC	45	45	165	130	130	110	11	200	/	15	3,5		
B103	FA	45	45	300	165	250	130	18	300	350	16	5	95	135
	FB	45	45	265	165	230	130	14	300	/	16	4		
	FC	45	45	215	165	180	130	14	250	/	16	4		
B123	FA	45	45	350	185	300	150	18	350	400	18	5	107,5	150
	FB	45	45	300	185	250	150	18	350	/	18	5		
	FC	45	45	265	185	230	150	14	300	/	18	4		
B143	FB	45	45	350	200	300	170	18	400	/	18	5	138	187,5
B153	FB	22,5	45	400	245	350	210	18	450	/	25	5	162,5	207,5
	FC	45	45	350	245	300	210	18	400	/	25	5		
B163	FA	22,5	45	500	298	450	255	18	550	/	28	5	202,5	256

Unless specified otherwise, the reduction unit is supplied with the accessories in pos. J referred to position B3/B5.

4.3.1 Torque arm: BA Mounting position

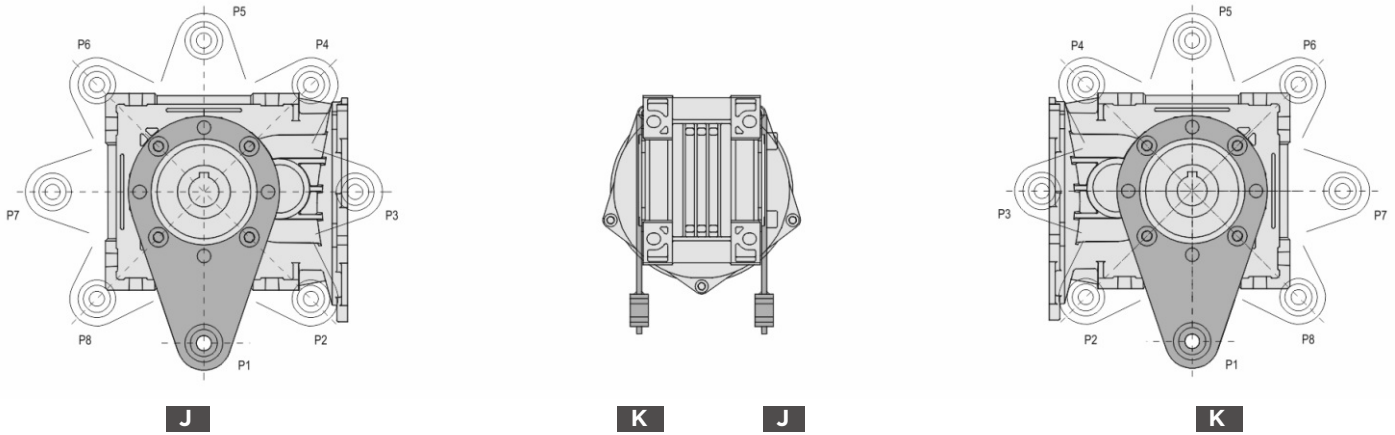

	P1		P2		P3		P4		P5		P6		P7		P8	
	J	K	J	K	J	K	J	K	J	K	J	K	J	K	J	K
BA42		*	/	/	/	/	/	/			/	/			/	/
BA52/A53			/	/	/	/	/	/								
BA72/A73			/	/	/	/	/	/								

(*) Not available with Shrink disc

(/) Not available

4.3.2 Torque arm: BA Dimensions

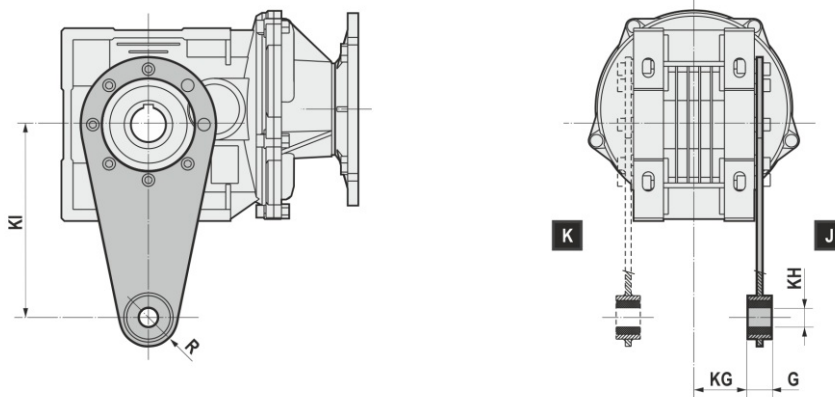

	KI	KG	KH	G	R
BA42	100	41	10	14	18
BA52/BA53	150	47	10	14	18
BA72/BA73	200	55,5	20	25	30

Unless specified otherwise, the reduction unit is supplied with the accessories in pos. J referred to position B3/B5.

4.3.3 Torque arm: B Mounting position

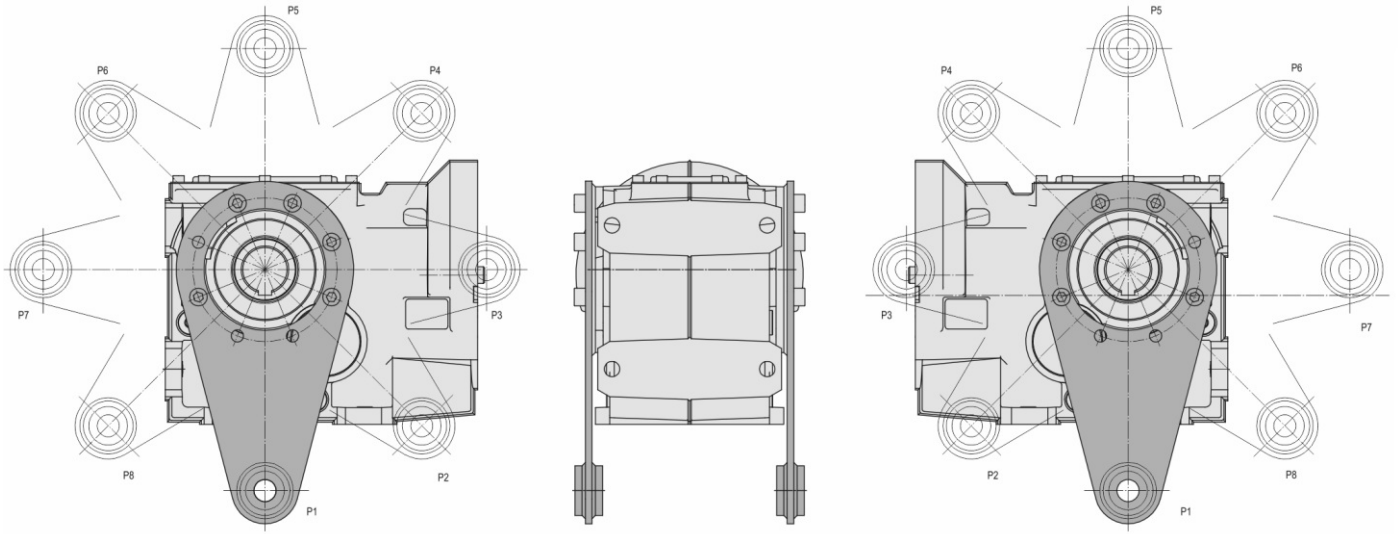

J

K

J

K

	P1		P2		P3		P4		P5		P6		P7		P8	
	J	K	J	K	J	K	J	K	J	K	J	K	J	K	J	K
B063					/	/										
B083			/	/	/	/										
B103			/	/	/	/										
B123			/	/	/	/										

(/) Not available

4.3.4 Torque arm: B063-083-103-123 Dimensions

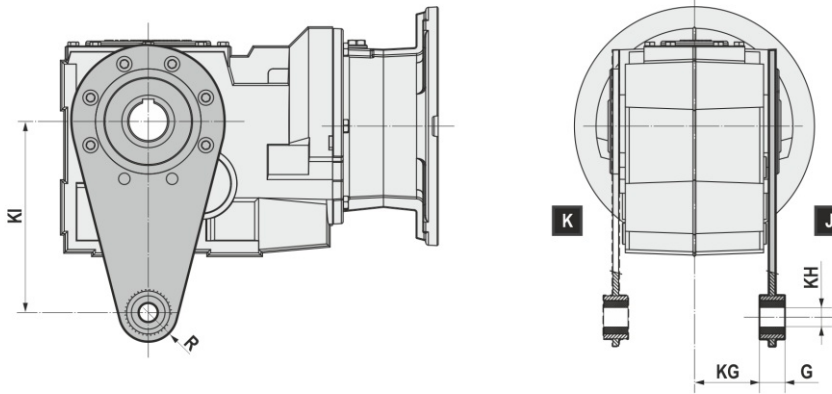

	KI	KG	KH	G	R
B063S	200	62	20	25	30
B083S	200	68,5	20	25	30
B103S	250	83	25	30	35
B123S	300	91,5	25	40	40
B063U	200	62	20	25	30
B083U	200	78,5	20	25	30
B103U	250	95	25	30	35
B123U	300	103,5	25	40	40

Unless specified otherwise, the reduction unit is supplied with the accessories in pos. J referred to position B3/B5.

4.3.5 Torque arm: B143-153-163 Dimensions

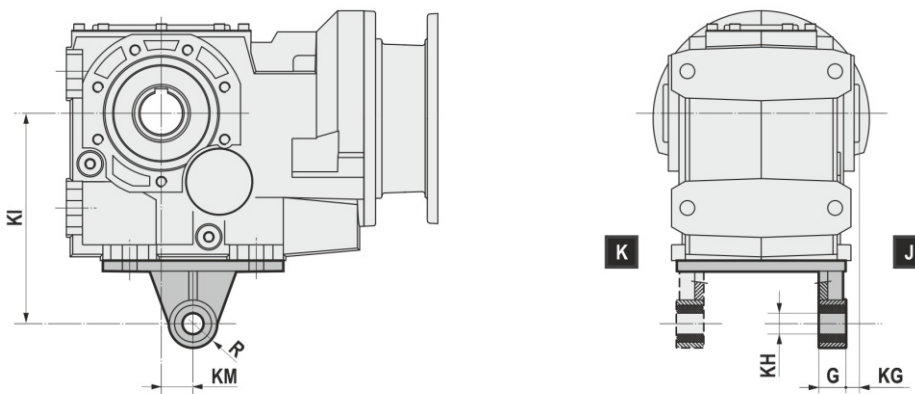

	KM	KI	KG	KH	G	R
B143	45	350	40	30	60	45
B153	45	450	45	30	60	45
B163	60	550	7,5	40	110	65

Unless specified otherwise, the reduction unit is supplied with the accessories in pos. J referred to position B3/B5.

4.4 BACKSTOP DEVICE

The gear reducer can be supplied with backstop device on input shaft. Backstop device allows output shaft rotation in only one sense of direction; according to the size, it is available in the input flange or in the motor with the same dimensions. It is important to specify the required sense of direction on the order. The backstop device is not available for mounting position V5 with motorsize IEC 100...280. On request, the direction of rotation of low speed shaft can be reversed; in this case, it is necessary to specify "opposite rotation" to catalogue when ordering.



Certified accessory for ATEX 3G/3D, only.

SENSE OF DIRECTION AVAILABLE STANDARD

BA..2/S - BA..3/C-D-P-L - B..3/C-D-P-L

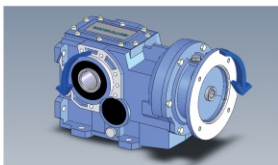

CLOCKWISE SENSE OF DIRECTION REFERRED TO HIGH SPEED SHAFT

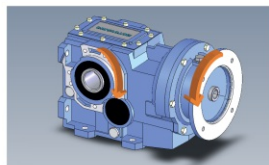

COUNTER CLOCKWISE SENSE OF DIRECTION REFERRED TO HIGH SPEED SHAFT

BA..2/C-D-P-L - BA..3/S - B..3/S-M

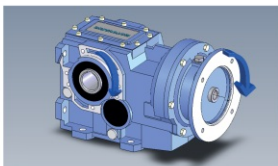

CLOCKWISE SENSE OF DIRECTION REFERRED TO HIGH SPEED SHAFT

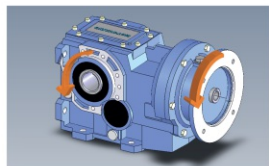

COUNTER CLOCKWISE SENSE OF DIRECTION REFERRED TO HIGH SPEED SHAFT

SENSE OF DIRECTION AVAILABLE OPPOSITE ROTATION

BA..2/S - BA..3/C-D-P-L - B..3/C-D-P-L

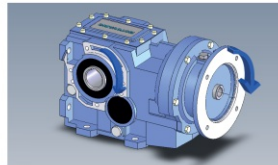

CLOCKWISE SENSE OF DIRECTION REFERRED TO HIGH SPEED SHAFT

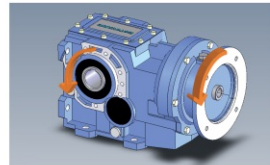

COUNTER CLOCKWISE SENSE OF DIRECTION REFERRED TO HIGH SPEED SHAFT

BA..2/C-D-P-L - BA..3/S - B..3/S-M

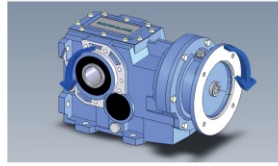

CLOCKWISE SENSE OF DIRECTION REFERRED TO HIGH SPEED SHAFT

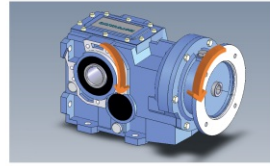

COUNTER CLOCKWISE SENSE OF DIRECTION REFERRED TO HIGH SPEED SHAFT

	063	071	080	090	100-112	132	160	180	200	225	250	280
	140x11	160x14	200x19	200x24	250x28	300x38	350x42	350x48	400x55	450x60	550x65	550x75
B063	B5	B5	B5	B5	B5							
B083			B5	B5	B5	B5						
B103			B5	B5	B5	B5	B5					
B123				B5	B5	B5	B5	B5				
B143					B5	B5	B5	B5	B5			
B153						B5	B5	B5	B5	B5		
B163							B5	B5	B5	B5	B5	B5

4.5 OUTPUT SHAFT WITH SHRINK DISC

Clean and degrease the surfaces of the shaft to be fitted to. Comply with the indicated tightening torque of screws (M_T).



Certified accessory for ATEX 3G/3D, only.

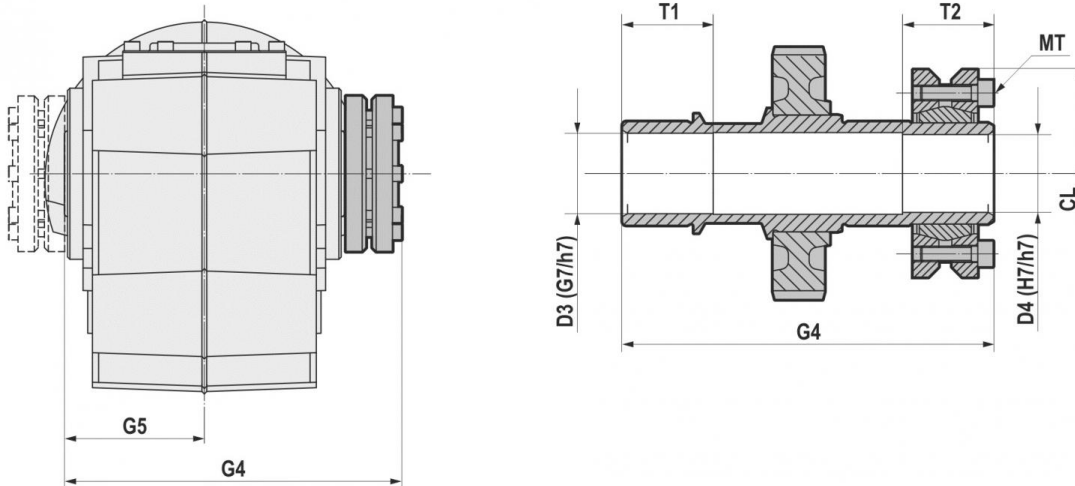

	D3	D4	G4	G5	T1	T2	CL	M_T 12,9 [Nm]
BA42	24	24	130	50	25	35	72	15
BA52-BA53	31	30	143	56	35	35	80	15
BA72-BA73	36	35	173	70	40	35	80	15
B063	36	35	173	70	40	35	80	15
B083	41	40	217	90	50	40	100	15
B103	51	50	248	105	55	40	115	15
B123	61	60	282	120	60	50	145	40
B143	72	70	355	150	70	65	170	50
B153	92	90	415	175	80	75	184	70
B163	102	100	512	222,5	100	100	215	70

4.6 THERMAL PROTECTOR

It is a PTC probe (see Fig. 1) with a trigger temperature of 120 °C. The customer shall perform the electric connection to the main electric panel to ensure the resistance thermometer correct operation regardless of the connections necessary for the system operation. The connection must apply the positive safety logic. Main powerboard, connections and logic must, taken together, provide a locking system to prevent, in the event of a shutdown, the unwanted start-up of the device. In case of intervention of the PTC probe, wait about 10 min. before resetting the main powerboard.

Unit electric characteristics:

Power to sensor <280 mW
 Voltage to sensor <30 Vdc
 Current to sensor <8 mA

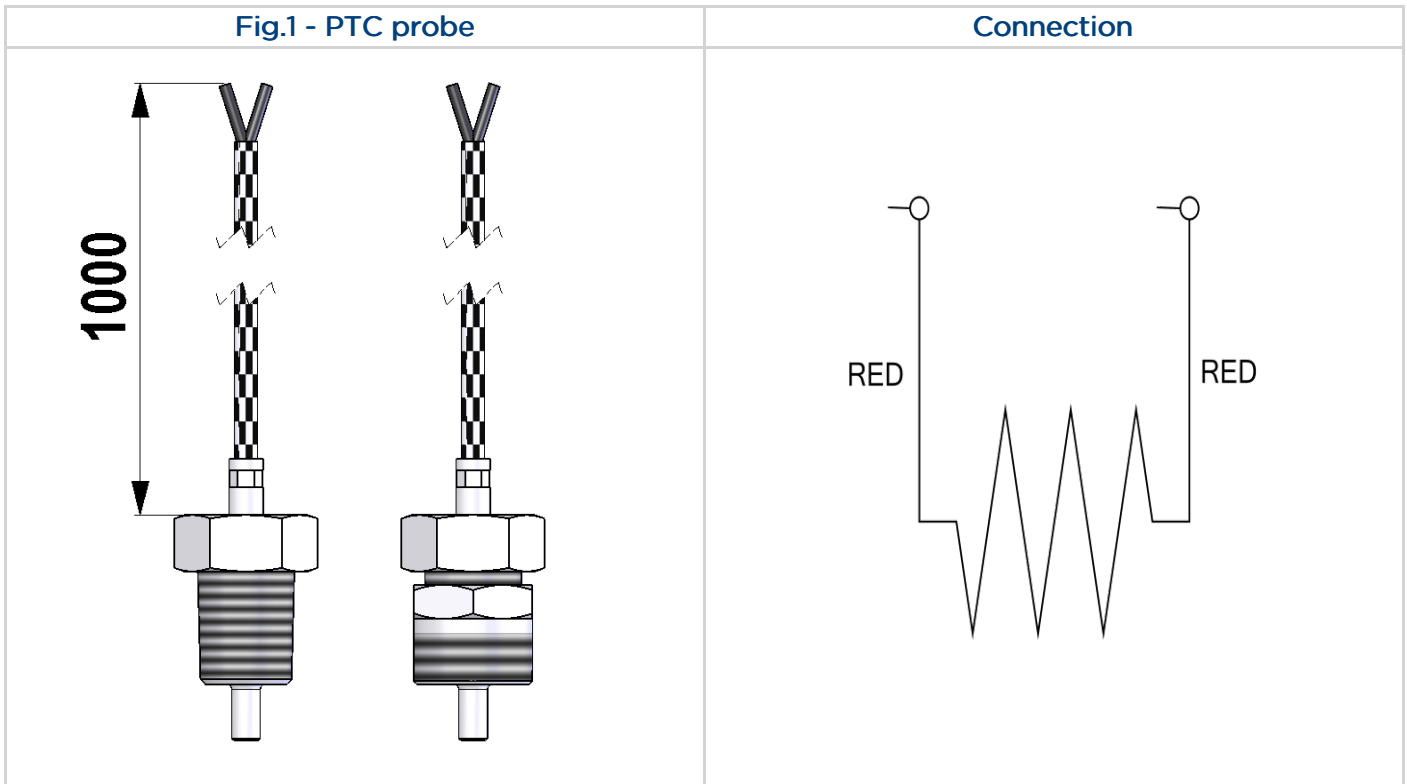

4.7 REINFORCED OIL SEALS FOR OUTPUT SHAFT

The reinforced seal can be done depending on the gearbox size by means of two oil seals or through the standard oil seal with VRM ring. The difference of the two solutions is explained on the drawings.

On request the gear reducer can be supplied with fluoroelastomer FPM (FKM) seals.

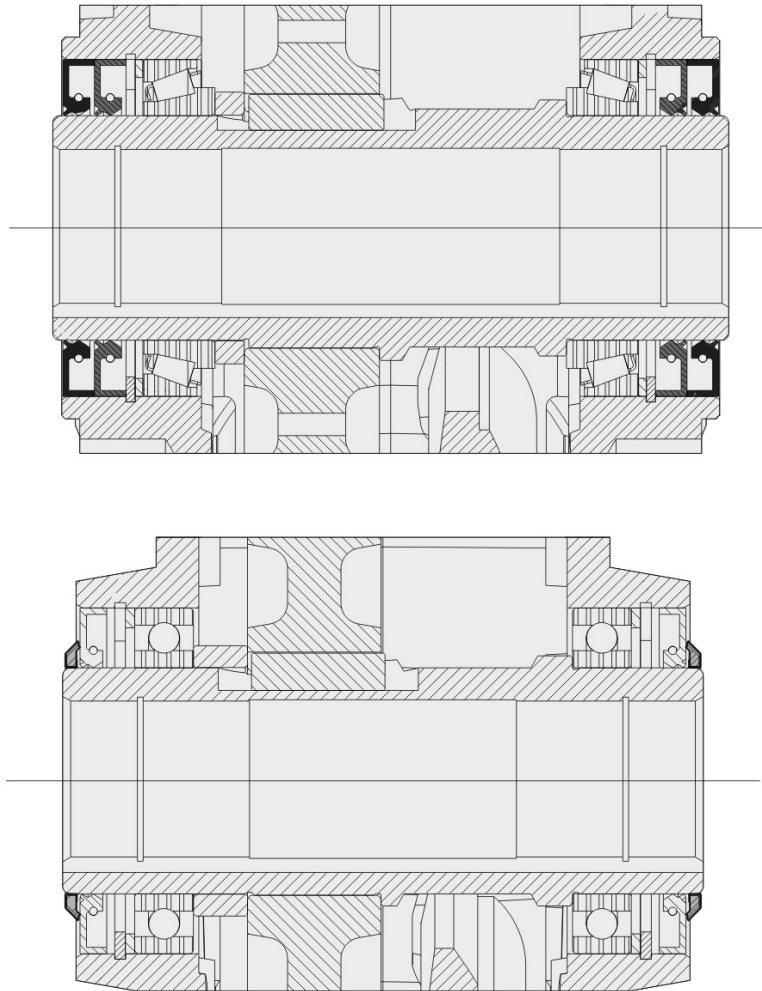

	Double oil seal	VRM ring
B063		x
B083		x
B103		x
B123		x
B143	x	
B153	x	
B163	x	

4.8 ASSEMBLING/DISASSEMBLING KIT

Mounting/dismounting kit for hollow shaft gear reducers with keyway that includes:

1. Retaining bolt
2. Circlip
3. Fixed nut
4. Forcing washer

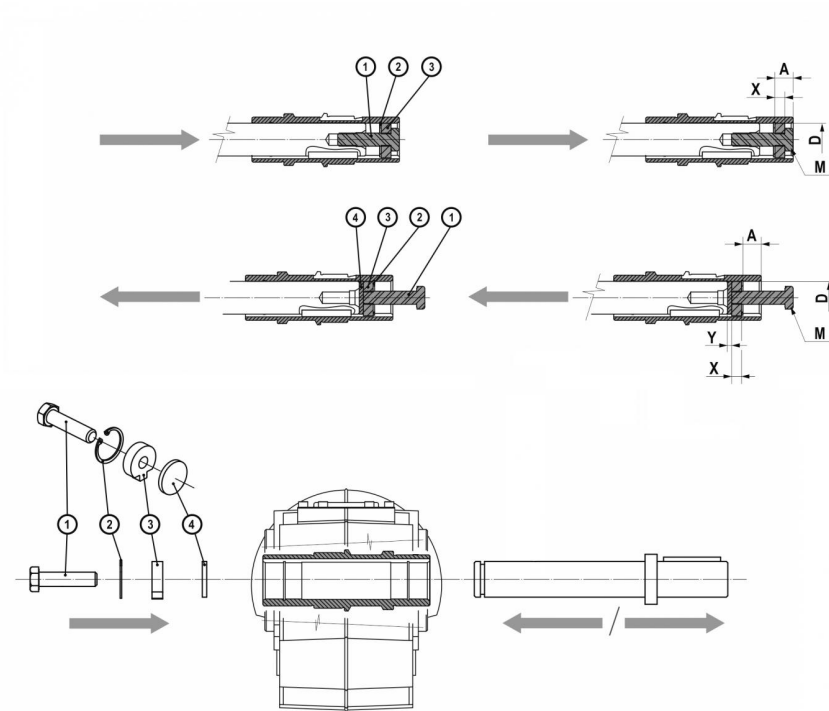

	D	A	X	Y	M
BA42	20	-	-	-	-
BA52/BA53	25	-	-	-	-
	28				
BA72/BA73	25	12	12	5	M12x45
	30	13,8	10		M10x35
B063	35	12	12	5	M12x45
	40				M16x50
B083	40	22,25	12	5	M16x50
	45				
B103	50	25	12	5	M16x50
B123	60	28	16	5	M20x70
B143	70	27,5	16	5	M20x70
B153	90	34	20	5	M24x60
B163	100	40	20	5	M24x120

5.1 ATEX AVAILABILITY

BA		ATEX 3G - 3D	ATEX 2G - 2D
BA42-BA5/3	C-D-S-P	✓	NO
	L	✓	NO
BA72/3	C-D-S-P	✓	NO
	L-M	✓	NO
CBA		ATEX 3G - 3D	ATEX 2G - 2D
CBA42-CBA5/3	C-D-S-P	✓	NO
	L	✓	NO
CBA72/3	C-D-S-P	✓	NO
	L-M	✓	NO
B		ATEX 3G - 3D	ATEX 2G - 2D
B063	C-D-S-P	✓	✓ - NO POS. B6/B7
	L-M	✓	NO
B083	C-D-S-P	✓	✓
	L-M	✓	NO
B103	C-D-S-P	✓	✓
	L-M	✓	NO
B123	C-D-S-P	✓	✓
	L-M	✓	NO
B143	C-D-S-P	✓	✓
	L-M	✓	NO
B153	C-D-S-P	✓	✓
	L-M	✓	NO
B163	C-D-S-P	✓	✓
	L-M	✓	NO
CB		ATEX 3G - 3D	ATEX 2G - 2D
CB063	C-D-S-P	✓	NO
	L-M	✓	NO
CB083	C-D-S-P	✓	NO
	L-M	✓	NO
CB103	C-D-S-P	✓	NO
	L-M	✓	NO
CB123	C-D-S-P	✓	NO
	L-M	✓	NO
CB143	C-D-S-P	✓	NO
	L-M	✓	NO

6.1 B/BA GEARED MOTORS (50Hz)

0,09 kW

n2 [rpm]	M2 [Nm]	fs	i	Gear reducer	Motor Size	Pole	Fr2 D-S-P [N]	Fr2 C [N]
25,5	32	3,2	33,78	BA42	63A	6	-	3507
18,3	45	2,3	47,12	BA42	63A	6	-	3918
15,0	55	1,9	57,43	BA42	63A	6	-	4000
13,4	61	1,5	64,13	BA42	63A	6	-	4000
13,3	62	2,8	64,87	BA52	63A	6	-	4000
11,7	67	2,8	73,70	BA53	63A	6	-	4000
11,0	75	1,3	78,17	BA42	63A	6	-	4000
10,9	76	2,3	79,07	BA52	63A	6	-	4000
9,2	85	2,2	93,33	BA53	63A	6	-	4000
7,7	101	1,8	111,61	BA53	63A	6	-	4000
6,3	124	1,5	136,53	BA53	63A	6	-	4000
5,7	136	2,8	149,73	BA73	63A	6	10000	5500
5,0	157	1,2	172,53	BA53	63A	6	-	4000
4,8	164	2,4	180,23	BA73	63A	6	10000	5500
4,4	179	1,0	197,11	BA53	63A	6	-	4000
3,9	203	1,9	222,93	BA73	63A	6	10000	5500
3,3	236	1,6	260,20	BA73	63A	6	10000	5500
2,7	292	1,3	321,85	BA73	63A	6	10000	5500
2,4	325	1,2	357,95	BA73	63A	6	10000	5500

0,12 kW

n2 [rpm]	M2 [Nm]	fs	i	Gear reducer	Motor Size	Pole	Fr2 D-S-P [N]	Fr2 C [N]
30,7	36	2,8	28,00	BA42	63B	6	-	3294
28,4	38	2,7	47,12	BA42	63A	4	-	3379
27,5	40	2,6	31,27	BA42	63B	6	-	3417
25,5	43	2,4	33,78	BA42	63B	6	-	3507
23,3	47	2,2	57,43	BA42	63A	4	-	3610
20,9	52	1,8	64,13	BA42	63A	4	-	3745
20,7	53	3,3	64,87	BA52	63A	4	-	4000
20,5	54	3,2	41,97	BA52	63B	6	-	4000
18,3	60	1,7	47,12	BA42	63B	6	-	3918
18,2	57	3,3	73,70	BA53	63A	4	-	4000
17,1	64	1,5	78,17	BA42	63A	4	-	4000
16,9	64	2,7	79,07	BA52	63A	4	-	4000
16,8	66	2,9	51,34	BA52	63B	6	-	4000
15,0	73	1,4	57,43	BA42	63B	6	-	4000
14,4	72	2,6	93,33	BA53	63A	4	-	4000
13,4	82	1,1	64,13	BA42	63B	6	-	4000
13,3	83	2,1	64,87	BA52	63B	6	-	4000
12,0	86	2,2	111,61	BA53	63A	4	-	4000
11,7	89	2,1	73,70	BA53	63B	6	-	4000

6.1 B/BA GEARED MOTORS (50Hz)

0,12 kW

n2 [rpm]	M2 [Nm]	fs	i	Gear reducer	Size	Motor Pole	Fr2 D-S-P [N]	Fr2 C [N]
10,9	101	1,7	79,07	BA52	63B	6	-	4000
9,8	105	1,8	136,53	BA53	63A	4	-	4000
9,2	113	1,6	93,33	BA53	63B	6	-	4000
8,9	115	3,3	149,73	BA73	63A	4	10000	5500
7,8	133	1,4	172,53	BA53	63A	4	-	4000
7,7	135	1,4	111,61	BA53	63B	6	-	4000
7,4	139	2,8	180,23	BA73	63A	4	10000	5500
7,1	146	2,6	120,34	BA73	63B	6	10000	5500
6,8	152	1,2	197,11	BA53	63A	4	-	4000
6,3	165	1,1	136,53	BA53	63B	6	-	4000
6,2	169	3,0	139,15	B063	63B	6	12000	7811
6,0	172	2,2	222,93	BA73	63A	4	10000	5500
5,7	181	2,1	149,73	BA73	63B	6	10000	5500
5,5	191	2,7	157,42	B063	63B	6	12000	8000
5,1	200	1,9	260,20	BA73	63A	4	10000	5500
4,8	218	1,8	180,23	BA73	63B	6	10000	5500
4,2	248	1,6	321,85	BA73	63A	4	10000	5500
3,9	270	1,4	222,93	BA73	63B	6	10000	5500
3,7	276	1,4	357,95	BA73	63A	4	10000	5500
3,3	315	1,2	260,20	BA73	63B	6	10000	5500
3,0	341	1,2	442,76	BA73	63A	4	10000	5500

0,15 kW

n2 [rpm]	M2 [Nm]	fs	i	Gear reducer	Size	Motor Pole	Fr2 D-S-P [N]	Fr2 C [N]
56,0	25	3,1	14,46	BA42	63C	6	-	2696
35,3	39	2,6	22,97	BA42	63C	6	-	3146
28,9	48	2,1	28,00	BA42	63C	6	-	3360
25,9	53	1,9	31,27	BA42	63C	6	-	3486
25,6	54	3,2	31,63	BA52	63C	6	-	3750
24,0	57	1,8	33,78	BA42	63C	6	-	3577
23,1	60	2,9	35,10	BA52	63C	6	-	3882
19,3	71	2,4	41,97	BA52	63C	6	-	4000
17,2	80	1,3	47,12	BA42	63C	6	-	3997
15,8	87	2,2	51,34	BA52	63C	6	-	4000
14,1	97	1,0	57,43	BA42	63C	6	-	4000
12,5	110	1,6	64,87	BA52	63C	6	-	4000
11,0	118	1,6	73,70	BA53	63C	6	-	4000
10,2	134	1,3	79,07	BA52	63C	6	-	4000
10,0	130	3,0	80,83	BA73	63C	6	10000	5500
8,7	150	1,2	93,33	BA53	63C	6	-	4000
8,3	156	2,4	97,29	BA73	63C	6	10000	5500

0,15 kW

n2 [rpm]	M2 [Nm]	fs	i	Gear reducer	Size	Motor Pole	Fr2 D-S-P [N]	Fr2 C [N]
8,0	163	3,1	101,20	B063	63C	6	12000	7162
7,3	179	1,0	111,61	BA53	63C	6	-	4000
7,2	180	2,8	111,74	B063	63C	6	12000	7385
6,7	193	2,0	120,34	BA73	63C	6	10000	5500
6,5	200	2,6	124,20	B063	63C	6	12000	7630
5,8	224	2,3	139,15	B063	63C	6	12000	7900
5,4	241	1,6	149,73	BA73	63C	6	10000	5500
5,1	253	2,0	157,42	B063	63C	6	12000	8000
4,5	290	1,3	180,23	BA73	63C	6	10000	5500
3,6	358	1,1	222,93	BA73	63C	6	10000	5500

0,18 kW

n2 [rpm]	M2 [Nm]	fs	i	Gear reducer	Size	Motor Pole	Fr2 D-S-P [N]	Fr2 C [N]
69,5	24	3,2	12,95	BA42	71A	6	-	2509
62,2	26	2,9	14,46	BA42	71A	6	-	2603
47,5	34	3,0	28,00	BA42	63B	4	-	2848
42,5	38	2,7	31,27	BA42	63B	4	-	2955
39,4	41	2,5	33,78	BA42	63B	4	-	3032
39,2	42	2,4	22,97	BA42	71A	6	-	3037
32,1	51	2,0	28,00	BA42	71A	6	-	3244
31,7	52	3,3	41,97	BA52	63B	4	-	3492
28,8	57	1,8	31,27	BA42	71A	6	-	3366
28,5	58	3,0	31,63	BA52	71A	6	-	3620
28,2	58	1,8	47,12	BA42	63B	4	-	3388
26,6	62	1,7	33,78	BA42	71A	6	-	3454
25,9	63	3,0	51,34	BA52	63B	4	-	3735
25,6	64	2,7	35,10	BA52	71A	6	-	3748
23,2	71	1,4	57,43	BA42	63B	4	-	3619
21,4	77	2,2	41,97	BA52	71A	6	-	3978
20,7	79	1,2	64,13	BA42	63B	4	-	3754
20,5	80	2,2	64,87	BA52	63B	4	-	4000
19,1	86	1,2	47,12	BA42	71A	6	-	3859
18,0	86	2,2	73,70	BA53	63B	4	-	4000
17,5	94	2,0	51,34	BA52	71A	6	-	4000
16,8	97	1,8	79,07	BA52	63B	4	-	4000
14,3	109	1,7	93,33	BA53	63B	4	-	4000
13,9	119	1,4	64,87	BA52	71A	6	-	4000
13,7	113	3,4	97,29	BA73	63B	4	10000	5500
12,2	128	1,5	73,70	BA53	71A	6	-	4000
11,9	130	1,4	111,61	BA53	63B	4	-	4000
11,4	145	1,2	79,07	BA52	71A	6	-	4000

6.1 B/BA GEARED MOTORS (50Hz)

0,18 kW

n2 [rpm]	M2 [Nm]	fs	i	Gear reducer	Motor Size	Pole	Fr2 D-S-P [N]	Fr2 C [N]
11,1	140	2,7	80,83	BA73	71A	6	10000	5500
11,1	140	2,7	120,34	BA73	63B	4	10000	5500
9,7	159	1,2	136,53	BA53	63B	4	-	4000
9,6	162	3,2	139,15	B063	63B	4	12000	6744
9,6	162	1,1	93,33	BA53	71A	6	-	4000
9,3	169	2,3	97,29	BA73	71A	6	10000	5500
8,9	176	2,9	101,20	B063	71A	6	12000	6893
8,9	174	2,2	149,73	BA73	63B	4	10000	5500
8,4	183	2,8	157,42	B063	63B	4	12000	7005
8,1	194	2,6	111,74	B063	71A	6	12000	7106
7,5	209	1,8	120,34	BA73	71A	6	10000	5500
7,4	210	1,8	180,23	BA73	63B	4	10000	5500
7,2	216	2,4	124,20	B063	71A	6	12000	7340
6,5	242	2,1	139,15	B063	71A	6	12000	7597
6,0	260	1,5	149,73	BA73	71A	6	10000	5500
6,0	259	1,5	222,93	BA73	63B	4	10000	5500
5,7	273	1,9	157,42	B063	71A	6	12000	7885
5,1	303	1,3	260,20	BA73	63B	4	10000	5500
5,0	313	1,2	180,23	BA73	71A	6	10000	5500
4,1	374	1,0	321,85	BA73	63B	4	10000	5500

0,22 kW

n2 [rpm]	M2 [Nm]	fs	i	Gear reducer	Motor Size	Pole	Fr2 D-S-P [N]	Fr2 C [N]
57,9	34	3,0	22,97	BA42	63C	4	-	2667
47,5	42	2,4	28,00	BA42	63C	4	-	2848
42,5	47	2,2	31,27	BA42	63C	4	-	2955
39,4	51	2,0	33,78	BA42	63C	4	-	3032
37,9	53	3,2	35,10	BA52	63C	4	-	3290
31,7	63	2,7	41,97	BA52	63C	4	-	3492
28,2	71	1,4	47,12	BA42	63C	4	-	3388
25,9	77	2,4	51,34	BA52	63C	4	-	3735
23,2	86	1,2	57,43	BA42	63C	4	-	3619
20,5	97	1,8	64,87	BA52	63C	4	-	4000
18,0	105	1,8	73,70	BA53	63C	4	-	4000
16,8	119	1,4	79,07	BA52	63C	4	-	4000
16,5	115	3,3	80,83	BA73	63C	4	10000	5500
14,3	133	1,4	93,33	BA53	63C	4	-	4000
13,7	138	2,8	97,29	BA73	63C	4	10000	5500
11,9	159	3,2	111,74	B063	63C	4	12000	6262
11,9	159	1,2	111,61	BA53	63C	4	-	4000
11,1	171	2,2	120,34	BA73	63C	4	10000	5500

6.1 B/BA GEARED MOTORS (50Hz)

0,22 kW

n2 [rpm]	M2 [Nm]	fs	i	Gear reducer	Size	Motor Pole	Fr2 D-S-P [N]	Fr2 C [N]
10,7	177	2,9	124,20	B063	63C	4	12000	6469
9,6	198	2,6	139,15	B063	63C	4	12000	6697
8,9	213	1,8	149,73	BA73	63C	4	10000	5500
8,4	224	2,3	157,42	B063	63C	4	12000	6953
7,4	256	1,5	180,23	BA73	63C	4	10000	5500
6,0	317	1,2	222,93	BA73	63C	4	10000	5500
5,1	370	1,0	260,20	BA73	63C	4	10000	5500

0,25 kW

n2 [rpm]	M2 [Nm]	fs	i	Gear reducer	Size	Motor Pole	Fr2 D-S-P [N]	Fr2 C [N]
91,3	25	3,1	14,46	BA42	63D/71A	4	-	2291
84,7	27	2,8	10,62	BA42	71B	6	-	2349
69,5	33	2,3	12,95	BA42	71B	6	-	2509
62,2	37	2,1	14,46	BA42	71B	6	-	2603
57,5	39	2,6	22,97	BA42	63D/71A	4	-	2673
54,6	42	2,4	16,47	BA42	71B	6	-	2718
47,1	48	2,1	28,00	BA42	63D/71A	4	-	2855
42,2	54	1,9	31,27	BA42	63D/71A	4	-	2962
41,7	54	3,2	31,63	BA52	63D/71A	4	-	3186
39,2	58	1,8	22,97	BA42	71B	6	-	3037
39,1	58	1,8	33,78	BA42	63D/71A	4	-	3040
37,6	60	2,8	35,10	BA52	63D/71A	4	-	3299
36,0	64	2,7	25,03	BA52	71B	6	-	3349
32,1	71	1,4	28,00	BA42	71B	6	-	3244
31,5	72	2,4	41,97	BA52	63D/71A	4	-	3501
28,8	80	1,3	31,27	BA42	71B	6	-	3366
28,5	81	2,1	31,63	BA52	71B	6	-	3620
28,0	81	1,3	47,12	BA42	63D/71A	4	-	3396
26,6	86	1,2	33,78	BA42	71B	6	-	3454
25,7	88	2,1	51,34	BA52	63D/71A	4	-	3745
25,6	89	1,9	35,10	BA52	71B	6	-	3748
23,0	99	1,0	57,43	BA42	63D/71A	4	-	3628
21,4	107	1,6	41,97	BA52	71B	6	-	3978
20,3	111	1,5	64,87	BA52	63D/71A	4	-	4000
17,9	120	1,6	73,70	BA53	63D/71A	4	-	4000
17,5	131	1,4	51,34	BA52	71B	6	-	4000
17,0	127	3,0	52,83	BA73	71B	6	10000	5441
16,7	136	1,3	79,07	BA52	63D/71A	4	-	4000
16,3	132	2,9	80,83	BA73	63D/71A	4	10000	5500
14,1	152	1,2	93,33	BA53	63D/71A	4	-	4000
13,9	165	1,0	64,87	BA52	71B	6	-	4000

0,25 kW

n2 [rpm]	M2 [Nm]	fs	i	Gear reducer	Motor Size	Pole	Fr2 D-S-P [N]	Fr2 C [N]
13,8	158	2,4	65,35	BA73	71B	6	10000	5500
13,6	158	2,4	97,29	BA73	63D/71A	4	10000	5500
13,0	167	3,1	69,16	B063	71B	6	12000	6064
13,0	165	3,1	101,20	B063	63D/71A	4	12000	6062
12,2	178	1,1	73,70	BA53	71B	6	-	4000
11,8	182	2,8	111,74	B063	63D/71A	4	12000	6249
11,8	182	1,0	111,61	BA53	63D/71A	4	-	4000
11,6	187	2,7	77,48	B063	71B	6	12000	6278
11,1	195	2,0	80,83	BA73	71B	6	10000	5500
11,0	196	2,0	120,34	BA73	63D/71A	4	10000	5500
10,6	202	2,5	124,20	B063	63D/71A	4	12000	6453
10,0	218	2,3	90,33	B063	71B	6	12000	6577
9,5	227	2,3	139,15	B063	63D/71A	4	12000	6678
9,3	235	1,6	97,29	BA73	71B	6	10000	5500
8,9	244	2,1	101,20	B063	71B	6	12000	6805
8,8	244	1,6	149,73	BA73	63D/71A	4	10000	5500
8,4	256	2,0	157,42	B063	63D/71A	4	12000	6929
8,1	269	1,9	111,74	B063	71B	6	12000	7009
7,5	290	1,3	120,34	BA73	71B	6	10000	5500
7,3	293	1,3	180,23	BA73	63D/71A	4	10000	5500
7,2	299	1,7	124,20	B063	71B	6	12000	7232
6,5	336	1,5	139,15	B063	71B	6	12000	7476
6,0	361	1,1	149,73	BA73	71B	6	10000	5500
5,9	363	1,1	222,93	BA73	63D/71A	4	10000	5500
5,7	380	1,3	157,42	B063	71B	6	12000	7748

0,37 kW

n2 [rpm]	M2 [Nm]	fs	i	Gear reducer	Motor Size	Pole	Fr2 D-S-P [N]	Fr2 C [N]
129,9	26	3,0	10,62	BA42	71B	4	-	2037
115,5	29	2,6	7,62	BA42	71C/80A	6	-	2118
106,6	31	2,4	12,95	BA42	71B	4	-	2176
95,4	35	2,2	14,46	BA42	71B	4	-	2257
83,8	40	2,5	16,47	BA42	71B	4	-	2357
82,8	41	1,9	10,62	BA42	71C/80A	6	-	2366
76,0	45	3,0	11,57	BA52	71C	6	-	2609
68,0	50	1,5	12,95	BA42	71C/80A	6	-	2528
60,9	56	1,4	14,46	BA42	71C/80A	6	-	2622
60,2	56	2,4	14,63	BA52	71C/80A	6	-	2820
60,1	56	1,8	22,97	BA42	71B	4	-	2634
55,1	61	2,8	25,03	BA52	71B	4	-	2904
53,4	63	1,6	16,47	BA42	71C/80A	6	-	2739

0,37 kW

n2 [rpm]	M2 [Nm]	fs	i	Gear reducer	Motor Size	Pole	Fr2 D-S-P [N]	Fr2 C [N]
51,4	66	2,6	17,11	BA52	71C/80A	6	-	2972
49,3	68	1,5	28,00	BA42	71B	4	-	2813
44,1	76	1,3	31,27	BA42	71B	4	-	2919
43,6	77	2,2	31,63	BA52	71B	4	-	3139
43,0	79	2,2	20,46	BA52	71C/80A	6	-	3154
40,9	82	1,3	33,78	BA42	71B	4	-	2995
39,3	85	2,0	35,10	BA52	71B	4	-	3250
38,3	89	1,2	22,97	BA42	71C/80A	6	-	3060
35,2	96	1,8	25,03	BA52	71C/80A	6	-	3374
33,6	101	1,0	28,00	BA42	80A	6	-	3198
32,9	102	1,7	41,97	BA52	71B	4	-	3450
28,4	119	3,0	33,04	BA72	80A	6	9172	4586
27,8	122	1,4	31,63	BA52	71C/80A	6	-	3647
26,9	125	1,5	51,34	BA52	71B	4	-	3689
26,1	122	3,2	52,83	BA73	71B	4	9436	4718
25,1	135	1,3	35,10	BA52	71C/80A	6	-	3776
23,0	147	2,3	40,87	BA72	80A	6	9845	4923
21,3	158	1,1	64,87	BA52	71B	4	-	3989
21,1	151	2,5	65,35	BA73	71B	4	10000	5065
21,0	162	1,1	41,97	BA52	71C/80A	6	-	4000
20,6	165	1,8	45,64	BA72	80A	6	10000	5107
20,4	158	2,7	43,22	B063	71C	6	12000	5214
20,0	159	3,2	69,16	B063	71B	4	12000	5248
20,0	160	2,4	43,89	BA73	71C/80A	6	10000	5153
18,7	170	1,1	73,70	BA53	71B	4	-	4000
18,3	185	1,0	51,34	BA52	80A	6	-	4000
17,8	179	2,9	77,48	B063	71B	4	12000	5431
17,3	185	2,8	50,81	B063	71C/80A	6	12000	5475
17,1	198	1,5	54,94	BA72	80A	6	10000	5433
17,1	186	2,1	80,83	BA73	71B	4	10000	5437
16,7	193	2,0	52,83	BA73	71C/80A	6	10000	5482
15,5	208	2,5	56,93	B063	71C/80A	6	12000	5665
15,3	208	2,5	90,33	B063	71B	4	12000	5687
14,2	224	1,7	97,29	BA73	71B	4	10000	5500
13,8	245	1,2	67,96	BA72	80A	6	10000	5500
13,6	233	2,2	101,20	B063	71B	4	12000	5883
13,6	236	3,1	69,14	B083	80A	6	18000	9098
13,5	239	1,6	65,35	BA73	71C/80A	6	10000	5500
12,9	250	2,9	73,14	B083	80A	6	18000	9257
12,7	252	2,0	69,16	B063	71C/80A	6	12000	6001
12,3	258	2,0	111,74	B063	71B	4	12000	6057
11,6	276	2,6	80,76	B083	80A	6	18000	9545

6.1 B/BA GEARED MOTORS (50Hz)

0,37 kW

n2 [rpm]	M2 [Nm]	fs	i	Gear reducer	Motor Size	Motor Pole	Fr2 D-S-P [N]	Fr2 C [N]
11,5	277	1,4	120,34	BA73	71B	4	10000	5500
11,4	283	1,8	77,48	B063	71C/80A	6	12000	6203
11,1	286	1,8	124,20	B063	71B	4	12000	6247
10,9	295	1,3	80,83	BA73	71C/80A	6	10000	5500
10,2	315	2,3	92,19	B083	80A	6	18000	9940
9,9	321	1,6	139,15	B063	71B	4	12000	6455
9,7	330	1,5	90,33	B063	71C/80A	6	12000	6484
9,3	344	2,1	100,57	B083	80A	6	18000	10207
9,2	345	1,1	149,73	BA73	71B	4	10000	5500
9,0	355	1,1	97,29	BA73	71C/80A	6	10000	5500
8,9	360	2,0	105,29	B083	80A	6	18000	10350
8,8	363	1,4	157,42	B063	71B	4	12000	6686
8,7	369	1,4	101,20	B063	71C/80A	6	12000	6697
8,1	397	1,8	116,25	B083	80A	6	18000	10664
7,9	408	1,3	111,74	B063	71C/80A	6	12000	6885
7,4	433	1,7	126,76	B083	80A	6	18000	10945
7,1	453	1,1	124,20	B063	71C/80A	6	12000	7090
6,5	495	1,5	144,77	B083	80A	6	18000	11387
6,5	494	3,1	144,69	B103	80A	6	22000	14062
6,3	508	1,0	139,15	B063	71C/80A	6	12000	7313
5,7	565	2,7	165,25	B103	80A	6	22000	14653

0,55 kW

n2 [rpm]	M2 [Nm]	fs	i	Gear reducer	Motor Size	Motor Pole	Fr2 D-S-P [N]	Fr2 C [N]
179,9	28	2,8	7,62	BA42	71C/80A	4	-	1827
129,0	39	2,0	10,62	BA42	71C/80A	4	-	2042
122,1	41	1,9	7,62	BA42	80B	6	-	2079
118,4	42	3,2	11,57	BA52	71C/80A	4	-	2251
117,5	43	3,2	7,91	BA52	80B	6	-	2256
105,8	47	1,6	12,95	BA42	71C/80A	4	-	2181
98,3	51	2,7	9,46	BA52	80B	6	-	2395
94,8	53	1,5	14,46	BA42	71C/80A	4	-	2263
93,7	53	2,6	14,63	BA52	71C/80A	4	-	2434
87,5	58	1,3	10,62	BA42	80B	6	-	2323
83,2	60	1,7	16,47	BA42	71C/80A	4	-	2363
80,4	63	2,2	11,57	BA52	80B	6	-	2561
80,1	62	2,7	17,11	BA52	71C/80A	4	-	2564
71,8	70	1,1	12,95	BA42	80B	6	-	2481
67,0	75	2,3	20,46	BA52	71C/80A	4	-	2722
63,6	79	1,7	14,63	BA52	80B	6	-	2769
59,6	84	1,2	22,97	BA42	71C/80A	4	-	2640

6.1 B/BA GEARED MOTORS (50Hz)

0,55 kW

n2 [rpm]	M2 [Nm]	fs	i	Gear reducer	Motor Size	Pole	Fr2 D-S-P [N]	Fr2 C [N]
56,5	89	1,1	16,47	BA42	80B	6	-	2689
54,7	91	1,9	25,03	BA52	71C/80A	4	-	2911
54,4	93	1,8	17,11	BA52	80B	6	-	2918
48,9	102	1,0	28,00	BA42	71C/80A	4	-	2820
45,5	111	1,5	20,46	BA52	80B	6	-	3097
43,3	115	1,5	31,63	BA52	71C/80A	4	-	3147
42,4	118	3,0	33,04	BA72	80A	4	8031	4016
39,0	128	1,3	35,10	BA52	71C/80A	4	-	3258
37,2	136	1,3	25,03	BA52	80B	6	-	3312
34,3	146	2,3	40,87	BA72	80A	4	8621	4311
33,9	149	2,4	27,45	BA72	80B	6	8653	4326
32,6	153	1,1	41,97	BA52	71C/80A	4	-	3458
31,2	151	2,5	43,89	BA73	71C/80A	4	8892	4446
30,7	163	1,8	45,64	BA72	80A	4	8944	4472
29,4	171	1,0	31,63	BA52	80B	6	-	3581
28,1	179	2,0	33,04	BA72	80B	6	9204	4602
27,8	172	2,5	33,43	B063	80B	6	12000	4666
27,0	175	2,9	50,81	B063	71C/80A	4	12000	4711
26,7	187	1,0	51,34	BA52	71C/80A	4	-	3698
25,9	182	2,1	52,83	BA73	71C/80A	4	9459	4730
25,5	196	1,5	54,94	BA72	80A	4	9515	4757
24,1	198	2,2	38,58	B063	80B	6	12000	4868
24,1	196	2,6	56,93	B063	71C/80A	4	12000	4873
22,8	221	1,5	40,87	BA72	80B	6	9880	4940
22,0	215	3,4	63,74	B083	80A	4	18000	7750
21,5	222	1,9	43,22	B063	80B	6	12000	5033
21,2	225	1,7	43,89	BA73	80B	6	10000	5059
21,0	225	1,7	65,35	BA73	71C/80A	4	10000	5077
20,6	242	1,2	67,96	BA72	80A	4	10000	5107
20,5	233	2,6	45,44	B083	80B	6	18000	7918
20,4	247	1,2	45,64	BA72	80B	6	10000	5126
20,2	233	3,1	69,14	B083	80A	4	18000	7947
19,8	239	2,1	69,16	B063	71C/80A	4	12000	5159
19,1	247	2,9	73,14	B083	80A	4	18000	8085
18,3	261	2,0	50,81	B063	80B	6	12000	5274
18,2	263	2,8	51,19	B083	80B	6	18000	8212
17,7	267	1,9	77,48	B063	71C/80A	4	12000	5331
17,6	271	1,4	52,83	BA73	80B	6	10000	5382
17,3	273	2,7	80,76	B083	80A	4	18000	8333
17,0	279	1,4	80,83	BA73	71C/80A	4	10000	5450
16,9	298	1,0	54,94	BA72	80B	6	10000	5452
16,7	285	2,5	55,52	B083	80B	6	18000	8418

6.1 B/BA GEARED MOTORS (50Hz)

0,55 kW

n2 [rpm]	M2 [Nm]	fs	i	Gear reducer	Motor Size	Pole	Fr2 D-S-P [N]	Fr2 C [N]
16,3	292	1,7	56,93	B063	80B	6	12000	5448
15,5	308	2,4	59,96	B083	80B	6	18000	8616
15,2	312	1,6	90,33	B063	71C/80A	4	12000	5568
15,2	311	2,3	92,19	B083	80A	4	18000	8675
14,6	327	2,2	63,74	B083	80B	6	18000	8777
14,2	335	1,1	65,35	BA73	80B	6	10000	5500
14,1	336	1,1	97,29	BA73	71C/80A	4	10000	5500
13,9	340	2,1	100,57	B083	80A	4	18000	8905
13,5	349	1,5	101,20	B063	71C/80A	4	12000	5748
13,5	355	2,0	69,14	B083	80B	6	18000	8994
13,4	355	1,4	69,16	B063	80B	6	12000	5754
13,3	356	2,0	105,29	B083	80A	4	18000	9029
12,7	376	1,9	73,14	B083	80B	6	18000	9146
12,3	386	1,3	111,74	B063	71C/80A	4	12000	5907
12,0	398	1,3	77,48	B063	80B	6	12000	5936
12,0	393	1,8	116,25	B083	80A	4	18000	9300
11,5	415	1,7	80,76	B083	80B	6	18000	9419
11,0	429	1,2	124,20	B063	71C/80A	4	12000	6079
11,0	428	1,7	126,76	B083	80A	4	18000	9541
10,3	464	1,1	90,33	B063	80B	6	12000	6186
10,1	473	1,5	92,19	B083	80B	6	18000	9793
10,1	474	3,2	92,31	B103	80B	6	22000	12129
9,8	480	1,1	139,15	B063	71C/80A	4	12000	6266
9,7	489	1,5	144,77	B083	80A	4	18000	9920
9,7	489	3,1	144,69	B103	80A	4	22000	12285
9,2	516	1,4	100,57	B083	80B	6	18000	10045
8,8	541	1,3	105,29	B083	80B	6	18000	10179
8,8	541	2,8	105,44	B103	80B	6	22000	12635
8,5	558	2,8	165,25	B103	80A	4	22000	12796
8,1	589	2,6	114,80	B103	80B	6	22000	12968
8,0	597	1,2	116,25	B083	80B	6	18000	10473
7,7	618	2,5	120,42	B103	80B	6	22000	13158
7,3	651	1,1	126,76	B083	80B	6	18000	10734
7,0	682	2,3	132,87	B103	80B	6	22000	13557
6,4	743	2,1	144,69	B103	80B	6	22000	13909
5,6	848	1,8	165,25	B103	80B	6	22000	14473

0,75 kW

n2 [rpm]	M2 [Nm]	fs	i	Gear reducer	Motor Size	Pole	Fr2 D-S-P [N]	Fr2 C [N]
183,8	37	2,1	7,62	BA42	80B	4	-	1814
148,0	46	3,0	9,46	BA52	80B	4	-	2090

0,75 kW

n2 [rpm]	M2 [Nm]	fs	i	Gear reducer	Motor Size	Pole	Fr2 D-S-P [N]	Fr2 C [N]
131,8	52	1,5	10,62	BA42	80B	4	-	2027
121,0	56	2,4	11,57	BA52	80B	4	-	2235
120,8	57	1,4	7,62	BA42	80C	6	-	2087
116,3	59	2,3	7,91	BA52	80C/90S	6	-	2264
108,1	63	1,2	12,95	BA42	80B	4	-	2165
97,2	71	1,9	9,46	BA52	80C/90S	6	-	2403
96,8	70	1,1	14,46	BA42	80B	4	-	2246
95,7	71	1,9	14,63	BA52	80B	4	-	2416
85,0	80	1,3	16,47	BA42	80B	4	-	2346
81,8	83	2,1	17,11	BA52	80B	4	-	2546
79,5	86	1,6	11,57	BA52	80C/90S	6	-	2570
73,9	93	3,2	12,44	BA72	90S	6	6671	3335
68,4	99	1,7	20,46	BA52	80B	4	-	2702
62,9	109	1,3	14,63	BA52	80C/90S	6	-	2779
61,7	111	3,2	14,91	BA72	90S	6	7085	3542
55,9	122	1,4	25,03	BA52	80B	4	-	2890
53,8	128	1,3	17,11	BA52	80C/90S	6	-	2928
51,3	134	2,7	17,94	BA72	90S	6	7537	3768
51,0	133	2,7	27,45	BA72	80B	4	7550	3775
45,0	153	1,1	20,46	BA52	80C/90S	6	-	3108
44,3	154	1,1	31,63	BA52	80B	4	-	3124
42,4	161	2,2	33,04	BA72	80B	4	8031	4016
41,9	154	2,8	33,43	B063	80B	4	12000	4071
41,5	166	2,2	22,19	BA72	90S	6	8090	4045
41,1	158	2,7	22,39	B063	80C/90S	6	12000	4093
39,9	171	1,0	35,10	BA52	80B	4	-	3235
36,3	178	2,4	38,58	B063	80B	4	12000	4247
35,3	185	2,3	26,09	B063	80C/90S	6	12000	4281
34,3	199	1,7	40,87	BA72	80B	4	8621	4311
33,5	205	1,7	27,45	BA72	80C/90S	6	8684	4342
32,8	198	2,2	28,03	B063	80C/90S	6	12000	4372
32,4	199	2,2	43,22	B063	80B	4	12000	4391
31,9	202	1,9	43,89	BA73	80B	4	8828	4414
30,7	222	1,3	45,64	BA72	80B	4	8944	4472
28,9	225	2,7	31,80	B083	80C/90S	6	18000	7043
27,8	247	1,5	33,04	BA72	80C/90S	6	9238	4619
27,6	234	2,2	50,81	B063	80B	4	12000	4601
27,5	237	1,8	33,43	B063	80C/90S	6	12000	4599
27,4	236	3,1	51,19	B083	80B	4	18000	7168
26,7	244	2,5	34,49	B083	80C/90S	6	18000	7220
26,5	243	1,6	52,83	BA73	80B	4	9391	4696
25,5	267	1,1	54,94	BA72	80B	4	9515	4757

0,75 kW

n2 [rpm]	M2 [Nm]	fs	i	Gear reducer	Motor Size	Pole	Fr2 D-S-P [N]	Fr2 C [N]
25,2	256	2,8	55,52	B083	80B	4	18000	7347
24,6	262	1,9	56,93	B063	80B	4	12000	4752
23,8	273	1,6	38,58	B063	80C/90S	6	12000	4790
23,4	276	2,6	59,96	B083	80B	4	18000	7520
23,2	280	2,2	39,60	B083	80C/90S	6	18000	7528
22,5	305	1,1	40,87	BA72	80C/90S	6	9916	4958
22,0	293	2,5	63,74	B083	80B	4	18000	7660
21,4	304	2,0	42,95	B083	80C/90S	6	18000	7714
21,4	301	1,3	65,35	BA73	80B	4	10000	5041
21,3	306	1,4	43,22	B063	80C/90S	6	12000	4944
21,0	311	1,2	43,89	BA73	80C/90S	6	10000	5077
20,2	318	1,6	69,16	B063	80B	4	12000	5017
20,2	322	1,9	45,44	B083	80C/90S	6	18000	7845
20,2	318	2,3	69,14	B083	80B	4	18000	7848
19,1	337	2,2	73,14	B083	80B	4	18000	7981
18,1	360	1,4	50,81	B063	80C/90S	6	12000	5167
18,1	357	1,4	77,48	B063	80B	4	12000	5175
18,0	362	2,0	51,19	B083	80C/90S	6	18000	8127
17,4	374	1,0	52,83	BA73	80C/90S	6	10000	5401
17,3	372	1,9	80,76	B083	80B	4	18000	8219
17,3	372	1,0	80,83	BA73	80B	4	10000	5411
16,6	393	1,8	55,52	B083	80C/90S	6	18000	8324
16,2	403	1,3	56,93	B063	80C/90S	6	12000	5327
15,5	416	1,2	90,33	B063	80B	4	12000	5391
15,3	424	1,7	59,96	B083	80C/90S	6	18000	8513
15,2	424	1,7	92,19	B083	80B	4	18000	8544
14,4	451	1,6	63,74	B083	80C/90S	6	18000	8666
14,2	459	3,2	64,89	B103	80C/90S	6	22000	10806
13,9	463	1,6	100,57	B083	80B	4	18000	8763
13,8	466	1,1	101,20	B063	80B	4	12000	5553
13,4	485	3,0	68,58	B103	80C/90S	6	22000	10991
13,3	489	1,0	69,16	B063	80C/90S	6	12000	5603
13,3	489	1,5	69,14	B083	80C/90S	6	18000	8872
13,3	485	1,5	105,29	B083	80B	4	18000	8879
13,3	486	3,2	105,44	B103	80B	4	22000	11030
12,8	504	1,0	111,74	B063	80B	4	12000	5665
12,6	518	1,4	73,14	B083	80C/90S	6	18000	9016
12,6	515	2,8	72,76	B103	80C/90S	6	22000	11191
12,2	529	2,9	114,80	B103	80B	4	22000	11319
12,0	535	1,4	116,25	B083	80B	4	18000	9135
11,7	559	2,6	78,92	B103	80C/90S	6	22000	11471
11,6	554	2,8	120,42	B103	80B	4	22000	11485

0,75 kW

n2 [rpm]	M2 [Nm]	fs	i	Gear reducer	Motor Size	Pole	Fr2 D-S-P [N]	Fr2 C [N]
11,4	572	1,3	80,76	B083	80C/90S	6	18000	9273
11,0	584	1,2	126,76	B083	80B	4	18000	9361
11,0	592	2,6	83,66	B103	80C/90S	6	22000	11675
10,5	612	2,5	132,87	B103	80B	4	22000	11832
10,0	652	1,1	92,19	B083	80C/90S	6	18000	9623
10,0	653	2,3	92,31	B103	80C/90S	6	22000	12026
9,7	667	1,1	144,77	B083	80B	4	18000	9715
9,7	666	2,3	144,69	B103	80B	4	22000	12139
9,1	712	1,0	100,57	B083	80C/90S	6	18000	9857
8,7	746	2,1	105,44	B103	80C/90S	6	22000	12514
8,5	761	2,0	165,25	B103	80B	4	22000	12630
8,0	812	1,9	114,80	B103	80C/90S	6	22000	12833
7,6	852	1,8	120,42	B103	80C/90S	6	22000	13015
7,1	920	3,3	129,96	B123	90S	6	30000	18750
6,9	940	1,6	132,87	B103	80C/90S	6	22000	13395
6,4	1024	1,5	144,69	B103	80C/90S	6	22000	13730
6,4	1022	2,9	144,43	B123	90S	6	30000	19323
5,7	1134	2,6	160,23	B123	90S	6	30000	19897
5,6	1169	1,3	165,25	B103	80C/90S	6	22000	14264
5,1	1277	2,3	180,40	B123	90S	6	30000	20000

0,92 kW

n2 [rpm]	M2 [Nm]	fs	i	Gear reducer	Motor Size	Pole	Fr2 D-S-P [N]	Fr2 C [N]
183,8	45	1,7	7,62	BA42	80C ⁽¹⁾	4	-	1814
176,9	47	2,9	7,91	BA52	80C ⁽¹⁾	4	-	1969
148,0	56	2,4	9,46	BA52	80C ⁽¹⁾	4	-	2090
131,8	63	1,2	10,62	BA42	80C ⁽¹⁾	4	-	2027
121,0	69	2,0	11,57	BA52	80C ⁽¹⁾	4	-	2235
95,7	87	1,6	14,63	BA52	80C ⁽¹⁾	4	-	2416
85,0	98	1,0	16,47	BA42	80C ⁽¹⁾	4	-	2346
81,8	102	1,7	17,11	BA52	80C ⁽¹⁾	4	-	2546
68,4	122	1,4	20,46	BA52	80C ⁽¹⁾	4	-	2702
55,9	149	1,1	25,03	BA52	80C ⁽¹⁾	4	-	2890
51,0	164	2,2	27,45	BA72	80C ⁽¹⁾	4	7550	3775
49,9	158	2,7	28,03	B063	80C ⁽¹⁾	4	12000	3825
42,4	197	1,8	33,04	BA72	80C ⁽¹⁾	4	8031	4016
41,9	189	2,3	33,43	B063	80C ⁽¹⁾	4	12000	4026
36,3	218	2,0	38,58	B063	80C ⁽¹⁾	4	12000	4195
35,4	224	2,7	39,60	B083	80C ⁽¹⁾	4	18000	6577
34,3	244	1,4	40,87	BA72	80C ⁽¹⁾	4	8621	4311
32,6	243	2,5	42,95	B083	80C ⁽¹⁾	4	18000	6741

⁽¹⁾ Available only with brake motor (TBS)

0,92 kW

n2 [rpm]	M2 [Nm]	fs	i	Gear reducer	Motor Size	Pole	Fr2 D-S-P [N]	Fr2 C [N]
32,4	244	1,8	43,22	B063	80C ⁽¹⁾	4	12000	4333
31,9	248	1,5	43,89	BA73	80C ⁽¹⁾	4	8828	4414
30,8	257	2,4	45,44	B083	80C ⁽¹⁾	4	18000	6857
30,7	272	1,1	45,64	BA72	80C ⁽¹⁾	4	8944	4472
27,6	287	1,8	50,81	B063	80C ⁽¹⁾	4	12000	4532
27,4	289	2,5	51,19	B083	80C ⁽¹⁾	4	18000	7106
26,5	298	1,3	52,83	BA73	80C ⁽¹⁾	4	9391	4696
25,2	314	2,3	55,52	B083	80C ⁽¹⁾	4	18000	7280
24,6	322	1,6	56,93	B063	80C ⁽¹⁾	4	12000	4675
23,4	339	2,1	59,96	B083	80C ⁽¹⁾	4	18000	7447
22,0	360	2,0	63,74	B083	80C ⁽¹⁾	4	18000	7583
21,4	369	1,0	65,35	BA73	80C ⁽¹⁾	4	10000	5041
20,2	391	1,3	69,16	B063	80C ⁽¹⁾	4	12000	4924
20,2	391	1,9	69,14	B083	80C ⁽¹⁾	4	18000	7765
19,1	413	1,8	73,14	B083	80C ⁽¹⁾	4	18000	7893
18,1	438	1,2	77,48	B063	80C ⁽¹⁾	4	12000	5071
17,7	446	3,3	78,92	B103	80C ⁽¹⁾	4	22000	10020
17,3	456	1,6	80,76	B083	80C ⁽¹⁾	4	18000	8121
16,7	473	3,2	83,66	B103	80C ⁽¹⁾	4	22000	10200
15,2	521	1,4	92,19	B083	80C ⁽¹⁾	4	18000	8433
15,2	521	2,9	92,31	B103	80C ⁽¹⁾	4	22000	10509
13,9	568	1,3	100,57	B083	80C ⁽¹⁾	4	18000	8641
13,3	595	1,2	105,29	B083	80C ⁽¹⁾	4	18000	8752
13,3	596	2,6	105,44	B103	80C ⁽¹⁾	4	22000	10939
12,2	648	2,4	114,80	B103	80C ⁽¹⁾	4	22000	11221
12,0	657	1,1	116,25	B083	80C ⁽¹⁾	4	18000	8994
11,6	680	2,3	120,42	B103	80C ⁽¹⁾	4	22000	11382
11,0	716	1,0	126,76	B083	80C ⁽¹⁾	4	18000	9208
10,5	750	2,0	132,87	B103	80C ⁽¹⁾	4	22000	11718
9,7	817	1,9	144,69	B103	80C ⁽¹⁾	4	22000	12015
8,5	933	1,6	165,25	B103	80C ⁽¹⁾	4	22000	12488

1,10 kW

n2 [rpm]	M2 [Nm]	fs	i	Gear reducer	Motor Size	Pole	Fr2 D-S-P [N]	Fr2 C [N]
185,1	54	1,4	7,62	BA42	80D ⁽¹⁾	4	-	1810
178,2	56	2,4	7,91	BA52	80D/90S	4	-	1964
149,0	67	2,0	9,46	BA52	80D/90S	4	-	2085
132,7	75	1,0	10,62	BA42	80D ⁽¹⁾	4	-	2022
121,0	83	1,6	11,57	BA52	80D/90S	4	-	2235
117,5	86	1,6	7,91	BA52	90L	6	-	2256
112,5	89	3,4	12,44	BA72	90S ⁽¹⁾	4	5800	2900

⁽¹⁾ Available only with brake motor (TBS)

1,10 kW

n2 [rpm]	M2 [Nm]	fs	i	Gear reducer	Motor Size	Pole	Fr2 D-S-P [N]	Fr2 C [N]
98,3	103	1,3	9,46	BA52	90L	6	-	2395
96,4	104	1,3	14,63	BA52	80D/90S	4	-	2410
93,9	106	3,4	14,91	BA72	90S ⁽¹⁾	4	6160	3080
92,4	109	2,7	10,06	BA72	90L/100LR	6	6192	3096
81,8	122	1,4	17,11	BA52	80D/90S	4	-	2546
80,4	125	1,1	11,57	BA52	90L	6	-	2561
78,0	128	2,8	17,94	BA72	90S	4	6552	3276
74,7	135	2,2	12,44	BA72	90L/100LR	6	6647	3323
68,4	146	1,2	20,46	BA52	80D/90S	4	-	2702
63,1	158	2,3	22,19	BA72	90S	4	7033	3517
62,5	151	2,9	22,39	B063	80D/90S	4	12000	3546
62,4	162	2,2	14,91	BA72	90L/100LR	6	7059	3530
61,3	156	2,7	15,18	B063	90L	6	12000	3565
54,7	175	2,5	17,00	B063	90L/100LR	6	12000	3685
53,7	176	2,5	26,09	B063	80D/90S	4	12000	3707
51,8	194	1,8	17,94	BA72	90L/100LR	6	7509	3755
51,0	196	1,8	27,45	BA72	80D/90S	4	7550	3775
49,9	189	2,3	28,03	B063	80D/90S	4	12000	3785
44,0	215	2,8	31,80	B083	80D/90S	4	18000	6110
42,4	236	1,5	33,04	BA72	80D/90S	4	8031	4016
41,9	226	1,9	33,43	B063	80D/90S	4	12000	3979
41,9	241	1,5	22,19	BA72	90L/100LR	6	8061	4030
41,5	230	1,9	22,39	B063	90L/100LR	6	12000	3985
40,8	234	2,6	22,82	B083	90L/100LR	6	18000	6252
40,6	233	2,6	34,49	B083	80D/90S	4	18000	6262
36,3	261	1,7	38,58	B063	80D/90S	4	12000	4141
35,6	268	1,6	26,09	B063	90L/100LR	6	12000	4158
35,4	267	2,3	39,60	B083	80D/90S	4	18000	6527
34,8	274	2,2	26,71	B083	90L/100LR	6	18000	6554
34,3	291	1,2	40,87	BA72	80D/90S	4	8621	4311
33,9	298	1,2	27,45	BA72	90L/100LR	6	8653	4326
33,2	288	1,5	28,03	B063	90L/100LR	6	12000	4240
32,6	290	2,1	42,95	B083	80D/90S	4	18000	6687
32,4	292	1,5	43,22	B063	80D/90S	4	12000	4271
31,9	296	1,3	43,89	BA73	80D/90S	4	8828	4414
31,5	303	2,0	29,50	B083	90L/100LR	6	18000	6749
30,8	307	2,0	45,44	B083	80D/90S	4	18000	6799
29,2	326	1,9	31,80	B083	90L/100LR	6	18000	6900
28,4	354	1,0	33,04	BA72	90L/100LR	6	9172	4586
27,8	343	1,3	33,43	B063	90L/100LR	6	12000	4444
27,6	343	1,5	50,81	B063	80D/90S	4	12000	4460
27,4	346	2,1	51,19	B083	80D/90S	4	18000	7041

⁽¹⁾ Available only with brake motor (TBS)

1,10 kW

n ₂ [rpm]	M ₂ [Nm]	f _s	i	Gear reducer	Motor		Fr ₂ D-S-P [N]	Fr ₂ C [N]
					Size	Pole		
27,0	354	1,7	34,49	B083	90L/100LR	6	18000	7066
26,5	357	1,1	52,83	BA73	80D/90S	4	9391	4696
25,2	375	1,9	55,52	B083	80D/90S	4	18000	7209
24,6	384	1,3	56,93	B063	80D/90S	4	12000	4594
24,1	396	1,1	38,58	B063	90L/100LR	6	12000	4613
23,5	407	1,5	39,60	B083	90L/100LR	6	18000	7354
23,4	405	1,8	59,96	B083	80D/90S	4	18000	7371
22,0	430	1,7	63,74	B083	80D/90S	4	18000	7501
21,7	441	1,4	42,95	B083	90L/100LR	6	18000	7527
21,6	438	3,3	64,89	B103	80D/90S	4	22000	9376
20,8	458	2,7	44,61	B103	90L/100LR	6	22000	9471
20,5	467	1,3	45,44	B083	90L/100LR	6	18000	7648
20,4	463	3,1	68,58	B103	80D/90S	4	22000	9535
20,2	467	1,1	69,16	B063	80D/90S	4	12000	4825
20,2	467	1,6	69,14	B083	80D/90S	4	18000	7677
19,7	486	2,5	47,28	B103	90L/100LR	6	22000	9640
19,2	491	3,0	72,76	B103	80D/90S	4	22000	9708
19,1	494	1,5	73,14	B083	80D/90S	4	18000	7799
18,5	516	2,8	50,24	B103	90L/100LR	6	22000	9818
18,2	526	1,4	51,19	B083	90L/100LR	6	18000	7908
17,7	533	2,7	78,92	B103	80D/90S	4	22000	9949
17,5	544	2,7	53,02	B103	90L/100LR	6	22000	9978
17,3	545	1,3	80,76	B083	80D/90S	4	18000	8018
16,7	570	1,3	55,52	B083	90L/100LR	6	18000	8088
16,7	565	2,7	83,66	B103	80D/90S	4	22000	10124
15,9	601	2,4	58,50	B103	90L/100LR	6	22000	10276
15,5	616	1,2	59,96	B083	90L/100LR	6	18000	8260
15,2	623	1,2	92,19	B083	80D/90S	4	18000	8315
15,2	623	2,5	92,31	B103	80D/90S	4	22000	10425
14,6	654	1,1	63,74	B083	90L/100LR	6	18000	8398
14,3	666	2,2	64,89	B103	90L/100LR	6	22000	10596
13,9	679	1,1	100,57	B083	80D/90S	4	18000	8513
13,6	704	2,1	68,58	B103	90L/100LR	6	22000	10770
13,5	710	1,0	69,14	B083	90L/100LR	6	18000	8583
13,3	711	1,0	105,29	B083	80D/90S	4	18000	8618
13,3	712	2,2	105,44	B103	80D/90S	4	22000	10843
12,8	747	1,9	72,76	B103	90L/100LR	6	22000	10959
12,2	775	2,0	114,80	B103	80D/90S	4	22000	11117
11,8	810	1,8	78,92	B103	90L/100LR	6	22000	11222
11,6	813	1,9	120,42	B103	80D/90S	4	22000	11272
11,1	859	1,8	83,66	B103	90L/100LR	6	22000	11413
10,8	878	3,4	129,96	B123	90S ⁽¹⁾	4	30000	16223

⁽¹⁾ Available only with brake motor (TBS)

6.1 B/BA GEARED MOTORS (50Hz)

1,10 kW

n2 [rpm]	M2 [Nm]	fs	i	Gear reducer	Motor		Fr2 D-S-P [N]	Fr2 C [N]
					Size	Pole		
10,5	897	1,7	132,87	B103	80D/90S	4	22000	11597
10,1	948	1,6	92,31	B103	90L/100LR	6	22000	11740
9,7	977	1,6	144,69	B103	80D/90S	4	22000	11884
9,7	975	3,1	144,43	B123	90S	4	30000	16711
9,5	1002	3,0	99,70	B123	100LR	6	30000	16778
8,8	1083	1,4	105,44	B103	90L/100LR	6	22000	12191
8,7	1095	2,7	106,65	B123	90L/100LR	6	30000	17193
8,7	1082	2,8	160,23	B123	90S	4	30000	17198
8,5	1116	1,4	165,25	B103	80D/90S	4	22000	12338
8,1	1179	1,3	114,80	B103	90L/100LR	6	22000	12484
7,8	1228	2,4	119,60	B123	90L/100LR	6	30000	17736
7,8	1218	2,5	180,40	B123	90S	4	30000	17762
7,7	1236	1,2	120,42	B103	90L/100LR	6	22000	12650
7,2	1334	2,2	129,96	B123	90L/100LR	6	30000	18135
7,0	1364	1,1	132,87	B103	90L/100LR	6	22000	12996
7,0	1371	3,1	136,44	B143	100LR	6	40000	40000
6,4	1486	1,0	144,69	B103	90L/100LR	6	22000	13299
6,4	1483	2,0	144,43	B123	90L/100LR	6	30000	18644
6,4	1504	2,8	149,59	B143	100LR	6	40000	40000
5,8	1645	1,8	160,23	B123	90L/100LR	6	30000	19149
5,7	1674	2,6	166,53	B143	100LR	6	40000	40000
5,2	1852	1,6	180,40	B123	90L/100LR	6	30000	19728
5,1	1882	2,3	187,24	B143	100LR	6	40000	40000

1,50 kW

n2 [rpm]	M2 [Nm]	fs	i	Gear reducer	Motor		Fr2 D-S-P [N]	Fr2 C [N]
					Size	Pole		
176,9	77	1,8	7,91	BA52	90L/90LA	4	-	1969
162,7	80	2,6	5,71	B063	100L/100LA	6	9188	2625
148,0	92	1,5	9,46	BA52	90L/90LA	4	-	2090
139,2	98	3,0	10,06	BA72	90L/90LA	4	5403	2701
135,2	96	2,5	6,88	B063	100L/100LA	6	9717	2776
127,0	103	2,5	7,32	B063	100L/100LA	6	9900	2829
121,0	113	1,2	11,57	BA52	90L/90LA	4	-	2235
112,5	121	2,5	12,44	BA72	90L/90LA	4	5800	2900
111,3	124	2,4	8,36	BA72	100L/100LA	6	5821	2910
101,5	128	2,6	9,16	B063	100L/100LA	6	10579	3023
93,9	145	2,5	14,91	BA72	90L/90LA	4	6160	3080
92,4	149	2,0	10,06	BA72	100L/100LA	6	6192	3096
90,6	144	2,6	10,26	B063	100L/100LA	6	10936	3124
84,3	154	2,5	11,03	B063	100L/100LA	6	11165	3190
82,3	157	2,8	17,00	B063	90L/90LA	4	11249	3214

6.1 B/BA GEARED MOTORS (50Hz)

1,50 kW

n ₂ [rpm]	M ₂ [Nm]	f _s	i	Gear reducer	Motor		Fr ₂ D-S-P [N]	Fr ₂ C [N]
					Size	Pole		
81,8	166	1,0	17,11	BA52	90L/90LA	4	-	2546
78,0	174	2,1	17,94	BA72	90L/90LA	4	6552	3276
75,3	173	2,4	12,35	B063	100L/100LA	6	11534	3296
74,7	184	1,6	12,44	BA72	100L/100LA	6	6647	3323
70,7	184	2,3	13,15	B063	100L/100LA	6	11741	3354
63,1	216	1,7	22,19	BA72	90L/90LA	4	7033	3517
62,5	206	2,1	22,39	B063	90L/90LA	4	12000	3475
62,4	220	1,6	14,91	BA72	100L/100LA	6	7059	3530
61,3	212	2,0	15,18	B063	100L/100LA	6	12000	3492
56,0	232	2,6	16,60	B083	100L/100LA	6	18000	5603
54,7	238	1,8	17,00	B063	100L/100LA	6	12000	3603
53,7	240	1,8	26,09	B063	90L/90LA	4	12000	3625
52,4	246	2,5	26,71	B083	90L/90LA	4	18000	5719
51,8	265	1,4	17,94	BA72	100L/100LA	6	7509	3755
51,0	267	1,3	27,45	BA72	90L/90LA	4	7550	3775
50,8	257	2,4	18,32	B083	100L/100LA	6	18000	5771
49,9	258	1,7	28,03	B063	90L/90LA	4	12000	3696
47,5	272	2,2	29,50	B083	90L/90LA	4	18000	5889
44,0	293	2,1	31,80	B083	90L/90LA	4	18000	6020
42,4	321	1,1	33,04	BA72	90L/90LA	4	8031	4016
41,9	308	1,4	33,43	B063	90L/90LA	4	12000	3873
41,9	328	1,1	22,19	BA72	100L/100LA	6	8061	4030
41,5	314	1,4	22,39	B063	100L/100LA	6	12000	3877
40,8	319	1,9	22,82	B083	100L/100LA	6	18000	6153
40,6	318	1,9	34,49	B083	90L/90LA	4	18000	6164
36,3	355	1,2	38,58	B063	90L/90LA	4	12000	4018
35,6	365	1,2	26,09	B063	100L/100LA	6	12000	4032
35,4	365	1,7	39,60	B083	90L/90LA	4	18000	6414
34,8	374	1,6	26,71	B083	100L/100LA	6	18000	6439
33,2	392	1,1	28,03	B063	100L/100LA	6	12000	4105
32,6	396	1,5	42,95	B083	90L/90LA	4	18000	6565
32,4	398	1,1	43,22	B063	90L/90LA	4	12000	4134
31,5	413	1,5	29,50	B083	100L/100LA	6	18000	6622
30,8	418	1,5	45,44	B083	90L/90LA	4	18000	6670
30,4	428	2,7	30,55	B103	100L/100LA	6	22000	8340
29,6	435	2,8	47,28	B103	90L/90LA	4	22000	8413
29,2	445	1,4	31,80	B083	100L/100LA	6	18000	6763
28,1	463	2,6	33,07	B103	100L/100LA	6	22000	8541
27,9	463	3,1	50,24	B103	90L/90LA	4	22000	8568
27,6	468	1,1	50,81	B063	90L/90LA	4	12000	4299
27,4	471	1,5	51,19	B083	90L/90LA	4	18000	6895
27,0	483	1,3	34,49	B083	100L/100LA	6	18000	6917

1,50 kW

n2 [rpm]	M2 [Nm]	fs	i	Gear reducer	Motor		Fr2 D-S-P [N]	Fr2 C [N]
					Size	Pole		
26,4	488	3,0	53,02	B103	90L/90LA	4	22000	8708
25,9	502	2,4	35,87	B103	100L/100LA	6	22000	8751
25,2	511	1,4	55,52	B083	90L/90LA	4	18000	7052
23,9	539	2,7	58,50	B103	90L/90LA	4	22000	8967
23,5	554	1,1	39,60	B083	100L/100LA	6	18000	7183
23,4	552	1,3	59,96	B083	90L/90LA	4	18000	7201
22,6	576	2,1	41,12	B103	100L/100LA	6	22000	9114
22,0	587	1,2	63,74	B083	90L/90LA	4	18000	7320
21,7	601	1,0	42,95	B083	100L/100LA	6	18000	7342
21,6	598	2,4	64,89	B103	90L/90LA	4	22000	9245
20,8	625	2,0	44,61	B103	100L/100LA	6	22000	9334
20,4	632	2,3	68,58	B103	90L/90LA	4	22000	9397
20,2	637	1,1	69,14	B083	90L/90LA	4	18000	7480
19,7	662	1,9	47,28	B103	100L/100LA	6	22000	9495
19,2	670	2,2	72,76	B103	90L/90LA	4	22000	9561
19,1	674	1,1	73,14	B083	90L/90LA	4	18000	7592
18,5	703	2,1	50,24	B103	100L/100LA	6	22000	9663
18,2	717	1,0	51,19	B083	100L/100LA	6	18000	7687
17,7	727	2,0	78,92	B103	90L/90LA	4	22000	9789
17,5	742	2,0	53,02	B103	100L/100LA	6	22000	9815
16,7	770	2,0	83,66	B103	90L/90LA	4	22000	9955
15,9	819	1,8	58,50	B103	100L/100LA	6	22000	10096
15,2	850	1,8	92,31	B103	90L/90LA	4	22000	10239
14,9	876	3,2	62,59	B123	100L/100LA	6	30000	14475
14,3	908	1,6	64,89	B103	100L/100LA	6	22000	10397
13,6	960	1,5	68,58	B103	100L/100LA	6	22000	10560
13,4	972	2,9	69,43	B123	100L/100LA	6	30000	14894
13,3	971	1,6	105,44	B103	90L/90LA	4	22000	10631
13,1	982	3,0	106,65	B123	90L/90LA	4	30000	14989
12,8	1019	1,4	72,76	B103	100L/100LA	6	22000	10736
12,5	1042	2,9	74,42	B123	100L/100LA	6	30000	15177
12,2	1057	1,5	114,80	B103	90L/90LA	4	22000	10885
11,8	1105	1,3	78,92	B103	100L/100LA	6	22000	10980
11,7	1101	2,7	119,60	B123	90L/90LA	4	30000	15460
11,6	1109	1,4	120,42	B103	90L/90LA	4	22000	11029
11,6	1121	2,7	80,04	B123	100L/100LA	6	30000	15476
11,1	1171	1,3	83,66	B103	100L/100LA	6	22000	11156
10,8	1197	2,5	129,96	B123	90L/90LA	4	30000	15804
10,5	1224	1,3	132,87	B103	90L/90LA	4	22000	11329
10,3	1258	2,4	89,87	B123	100L/100LA	6	30000	15955
10,1	1292	1,2	92,31	B103	100L/100LA	6	22000	11456
9,9	1318	3,2	94,13	B143	100LA	6	40000	40000

1,50 kW

n2 [rpm]	M2 [Nm]	fs	i	Gear reducer	Motor Size	Motor Pole	Fr2 D-S-P [N]	Fr2 C [N]
9,7	1332	1,2	144,69	B103	90L/90LA	4	22000	11592
9,7	1330	2,2	144,43	B123	90L/90LA	4	30000	16245
9,3	1396	2,1	99,70	B123	100L/100LA	6	30000	16388
8,8	1476	1,0	105,44	B103	100L/100LA	6	22000	11867
8,8	1482	2,9	105,83	B143	100L/100LA	6	40000	40000
8,7	1493	2,0	106,65	B123	100L/100LA	6	30000	16670
8,7	1476	2,0	160,23	B123	90L/90LA	4	30000	16681
8,5	1522	1,0	165,25	B103	90L/90LA	4	22000	12005
8,3	1567	2,7	111,94	B143	100L/100LA	6	40000	40000
7,8	1675	1,8	119,60	B123	100L/100LA	6	30000	17150
7,8	1661	1,8	180,40	B123	90L/90LA	4	30000	17180
7,5	1745	2,4	124,62	B143	100L/100LA	6	40000	40000
7,2	1820	1,6	129,96	B123	100L/100LA	6	30000	17497
6,8	1910	2,2	136,44	B143	100L/100LA	6	40000	40000
6,4	2022	1,5	144,43	B123	100L/100LA	6	30000	17936
6,2	2094	2,0	149,59	B143	100L/100LA	6	40000	40000
5,8	2243	1,3	160,23	B123	100L/100LA	6	30000	18363
5,6	2332	1,8	166,53	B143	100L/100LA	6	40000	40000
5,2	2526	1,2	180,40	B123	100L/100LA	6	30000	18843
5,0	2622	1,6	187,24	B143	100L/100LA	6	40000	40000

1,85 kW

n2 [rpm]	M2 [Nm]	fs	i	Gear reducer	Motor Size	Motor Pole	Fr2 D-S-P [N]	Fr2 C [N]
176,9	95	1,4	7,91	BA52	90LB ⁽¹⁾	4	-	1969
167,5	100	3,0	8,36	BA72	90LB ⁽¹⁾	4	5079	2540
162,7	99	2,1	5,71	B063	100LB	6	9103	2601
148,0	113	1,2	9,46	BA52	90LB ⁽¹⁾	4	-	2090
139,2	121	2,5	10,06	BA72	90LB ⁽¹⁾	4	5403	2701
135,2	119	2,1	6,88	B063	100LB	6	9615	2747
127,0	126	2,0	7,32	B063	100LB	6	9792	2798
119,1	135	2,7	7,81	B083	100LB	6	15480	4423
112,5	149	2,0	12,44	BA72	90LB ⁽¹⁾	4	5800	2900
111,3	152	2,0	8,36	BA72	100LB	6	5821	2910
106,5	149	2,9	13,15	B063	90LB ⁽¹⁾	4	10310	2946
101,5	158	2,1	9,16	B063	100LB	6	10444	2984
93,9	179	2,0	14,91	BA72	90LB ⁽¹⁾	4	6160	3080
92,4	183	1,6	10,06	BA72	100LB	6	6192	3096
92,3	172	2,5	15,18	B063	90LB ⁽¹⁾	4	10738	3068
90,6	177	2,1	10,26	B063	100LB	6	10784	3081
88,6	181	2,6	10,49	B083	100LB	6	16934	4838
84,3	190	2,0	11,03	B063	100LB	6	11002	3144

⁽¹⁾ Available only with brake motor (TBS)

1,85 kW

n2 [rpm]	M2 [Nm]	fs	i	Gear reducer	Motor Size	Pole	Fr2 D-S-P [N]	Fr2 C [N]
82,3	193	2,2	17,00	B063	90LB ⁽¹⁾	4	11084	3167
80,3	200	2,7	11,59	B083	100LB	6	17445	4984
78,0	215	1,7	17,94	BA72	90LB ⁽¹⁾	4	6552	3276
75,3	213	2,0	12,35	B063	100LB	6	11352	3244
74,7	227	1,3	12,44	BA72	100LB	6	6647	3323
70,7	227	1,9	13,15	B063	100LB	6	11547	3299
64,5	249	2,3	14,43	B083	100LB	6	18000	5319
63,1	266	1,3	22,19	BA72	90LB ⁽¹⁾	4	7033	3517
62,5	254	1,7	22,39	B063	90LB ⁽¹⁾	4	11945	3413
62,4	272	1,3	14,91	BA72	100LB	6	7059	3530
61,4	259	2,4	22,82	B083	90LB ⁽¹⁾	4	18000	5399
61,3	262	1,6	15,18	B063	100LB	6	11997	3428
56,0	287	2,1	16,60	B083	100LB	6	18000	5541
54,7	294	1,5	17,00	B063	100LB	6	12000	3531
53,7	296	1,5	26,09	B063	90LB ⁽¹⁾	4	12000	3552
52,4	303	2,0	26,71	B083	90LB ⁽¹⁾	4	18000	5653
51,8	327	1,1	17,94	BA72	100LB	6	7509	3755
51,0	329	1,1	27,45	BA72	90LB ⁽¹⁾	4	7550	3775
50,8	316	1,9	18,32	B083	100LB	6	18000	5701
49,9	318	1,4	28,03	B063	90LB ⁽¹⁾	4	12000	3618
47,5	335	1,8	29,50	B083	90LB ⁽¹⁾	4	18000	5816
44,0	361	1,7	31,80	B083	90LB ⁽¹⁾	4	18000	5941
41,9	380	1,1	33,43	B063	90LB ⁽¹⁾	4	12000	3780
41,5	387	1,1	22,39	B063	100LB	6	12000	3783
40,8	394	1,5	22,82	B083	100LB	6	18000	6067
40,6	392	1,6	34,49	B083	90LB ⁽¹⁾	4	18000	6079
39,2	409	2,5	23,70	B103	100LB	6	22000	7656
35,4	450	1,4	39,60	B083	90LB ⁽¹⁾	4	18000	6316
35,1	458	2,4	26,51	B103	100LB	6	22000	7918
34,8	461	1,3	26,71	B083	100LB	6	18000	6338
34,0	467	2,6	41,12	B103	90LB ⁽¹⁾	4	22000	7992
32,6	488	1,3	42,95	B083	90LB ⁽¹⁾	4	18000	6458
31,5	509	1,2	29,50	B083	100LB	6	18000	6511
31,4	507	2,4	44,61	B103	90LB ⁽¹⁾	4	22000	8188
30,8	516	1,2	45,44	B083	90LB ⁽¹⁾	4	18000	6557
30,4	528	2,2	30,55	B103	100LB	6	22000	8258
29,6	537	2,3	47,28	B103	90LB ⁽¹⁾	4	22000	8330
29,2	549	1,1	31,80	B083	100LB	6	18000	6643
28,1	571	2,1	33,07	B103	100LB	6	22000	8452
27,9	571	2,5	50,24	B103	90LB ⁽¹⁾	4	22000	8479
27,4	581	1,2	51,19	B083	90LB ⁽¹⁾	4	18000	6768
27,0	596	1,0	34,49	B083	100LB	6	18000	6787

⁽¹⁾ Available only with brake motor (TBS)

1,85 kW

n2 [rpm]	M2 [Nm]	fs	i	Gear reducer	Motor Size	Pole	Fr2 D-S-P [N]	Fr2 C [N]
26,4	602	2,4	53,02	B103	90LB ⁽¹⁾	4	22000	8614
25,9	619	2,0	35,87	B103	100LB	6	22000	8655
25,2	631	1,1	55,52	B083	90LB ⁽¹⁾	4	18000	6914
23,9	664	2,2	58,50	B103	90LB ⁽¹⁾	4	22000	8863
23,4	681	1,1	59,96	B083	90LB ⁽¹⁾	4	18000	7052
22,6	710	1,7	41,12	B103	100LB	6	22000	9003
22,0	724	1,0	63,74	B083	90LB ⁽¹⁾	4	18000	7162
21,6	737	2,0	64,89	B103	90LB ⁽¹⁾	4	22000	9131
20,8	770	1,6	44,61	B103	100LB	6	22000	9215
20,4	779	1,9	68,58	B103	90LB ⁽¹⁾	4	22000	9276
19,7	817	1,5	47,28	B103	100LB	6	22000	9368
19,2	826	1,8	72,76	B103	90LB ⁽¹⁾	4	22000	9432
18,7	860	2,7	49,80	B123	100LB	6	30000	13362
18,5	868	1,7	50,24	B103	100LB	6	22000	9529
17,7	896	1,6	78,92	B103	90LB ⁽¹⁾	4	22000	9650
17,5	916	1,6	53,02	B103	100LB	6	22000	9673
17,5	909	3,3	80,04	B123	90LB ⁽¹⁾	4	30000	13614
17,1	938	2,9	54,30	B123	100LB	6	30000	13679
16,7	950	1,6	83,66	B103	90LB ⁽¹⁾	4	22000	9807
15,9	1010	1,4	58,50	B103	100LB	6	22000	9939
15,7	1025	2,7	59,36	B123	100LB	6	30000	14009
15,2	1048	1,5	92,31	B103	90LB ⁽¹⁾	4	22000	10076
14,9	1081	2,6	62,59	B123	100LB	6	30000	14207
14,3	1120	1,3	64,89	B103	100LB	6	22000	10223
13,6	1184	1,2	68,58	B103	100LB	6	22000	10376
13,4	1199	2,3	69,43	B123	100LB	6	30000	14596
13,3	1198	1,3	105,44	B103	90LB ⁽¹⁾	4	22000	10445
13,1	1211	2,5	106,65	B123	90LB ⁽¹⁾	4	30000	14688
12,8	1256	1,2	72,76	B103	100LB	6	22000	10540
12,5	1285	2,3	74,42	B123	100LB	6	30000	14857
12,2	1304	1,2	114,80	B103	90LB ⁽¹⁾	4	22000	10682
12,1	1332	3,2	77,12	B143	100LB	6	40000	40000
11,8	1363	1,1	78,92	B103	100LB	6	22000	10768
11,7	1358	2,2	119,60	B123	90LB ⁽¹⁾	4	30000	15122
11,6	1368	1,1	120,42	B103	90LB ⁽¹⁾	4	22000	10817
11,6	1382	2,2	80,04	B123	100LB	6	30000	15132
11,1	1445	1,1	83,66	B103	100LB	6	22000	10931
10,9	1477	2,9	85,54	B143	100LB	6	40000	40000
10,8	1476	2,0	129,96	B123	90LB ⁽¹⁾	4	30000	15438
10,5	1509	1,0	132,87	B103	90LB ⁽¹⁾	4	22000	11095
10,3	1552	1,9	89,87	B123	100LB	6	30000	15570
9,9	1625	2,6	94,13	B143	100LB	6	40000	40000

⁽¹⁾ Available only with brake motor (TBS)

1,85 kW

n2 [rpm]	M2 [Nm]	fs	i	Gear reducer	Motor Size	Pole	Fr2 D-S-P [N]	Fr2 C [N]
9,7	1640	1,8	144,43	B123	90LB ⁽¹⁾	4	30000	15838
9,3	1722	1,7	99,70	B123	100LB	6	30000	15960
8,8	1828	2,3	105,83	B143	100LB	6	40000	40000
8,7	1842	1,6	106,65	B123	100LB	6	30000	16213
8,7	1820	1,6	160,23	B123	90LB ⁽¹⁾	4	30000	16229
8,3	1933	2,2	111,94	B143	100LB	6	40000	40000
7,8	2065	1,4	119,60	B123	100LB	6	30000	16637
7,8	2049	1,5	180,40	B123	90LB ⁽¹⁾	4	30000	16671
7,5	2152	2,0	124,62	B143	100LB	6	40000	40000
7,2	2244	1,3	129,96	B123	100LB	6	30000	16940
6,8	2356	1,8	136,44	B143	100LB	6	40000	40000
6,4	2494	1,2	144,43	B123	100LB	6	30000	17317
6,2	2583	1,7	149,59	B143	100LB	6	40000	40000
5,8	2767	1,1	160,23	B123	100LB	6	30000	17676
5,6	2876	1,5	166,53	B143	100LB	6	40000	40000
5,0	3233	1,3	187,24	B143	100LB	6	40000	40000

2,20 kW

n2 [rpm]	M2 [Nm]	fs	i	Gear reducer	Motor Size	Pole	Fr2 D-S-P [N]	Fr2 C [N]
250,2	76	2,8	5,71	B063	100LA/112MR	4	7944	2270
206,4	92	2,7	6,88	B063	100LA/112MR	4	8415	2404
193,9	98	2,6	7,32	B063	100LA/112MR	4	8572	2449
171,1	117	2,6	8,36	BA72	100LA/112MR	4	5043	2522
162,7	117	1,8	5,71	B063	112M/112MA	6	9019	2577
155,0	122	2,6	9,16	B063	100LA/112MR	4	9153	2615
141,2	141	2,1	10,06	BA72	100LA/112MR	4	5377	2689
138,4	137	2,5	10,26	B063	100LA/112MR	4	9457	2702
135,2	141	1,7	6,88	B063	112M/112MA	6	9514	2718
128,8	147	2,7	11,03	B063	100LA/112MR	4	9653	2758
127,0	150	1,7	7,32	B063	112M/112MA	6	9684	2767
119,1	160	2,2	7,81	B083	112M/112MA	6	15377	4393
114,9	165	2,5	12,35	B063	100LA/112MR	4	9967	2848
114,1	175	1,7	12,44	BA72	100LA/112MR	4	5772	2886
111,3	181	1,6	8,36	BA72	112M/112MA	6	5821	2910
108,0	175	2,4	13,15	B063	100LA/112MR	4	10143	2898
107,9	177	2,4	8,62	B083	112M/112MA	6	15842	4526
101,5	188	1,8	9,16	B063	112M/112MA	6	10309	2945
95,3	210	1,7	14,91	BA72	100LA/112MR	4	6131	3065
93,6	202	2,1	15,18	B063	100LA/112MR	4	10550	3014
92,4	218	1,4	10,06	BA72	112M/112MA	6	6192	3096
90,6	211	1,8	10,26	B063	112M/112MA	6	10633	3038

⁽¹⁾ Available only with brake motor (TBS)

2,20 kW

n2 [rpm]	M2 [Nm]	fs	i	Gear reducer	Motor		Fr2 D-S-P [N]	Fr2 C [N]
					Size	Pole		
88,6	216	2,2	10,49	B083	112M/112MA	6	16795	4799
85,6	221	2,8	16,60	B083	100LA/112MR	4	16979	4851
84,3	226	1,7	11,03	B063	112M/112MA	6	10840	3097
83,5	226	1,9	17,00	B063	100LA/112MR	4	10878	3108
80,3	238	2,3	11,59	B083	112M/112MA	6	17292	4941
79,1	252	1,4	17,94	BA72	100LA/112MR	4	6521	3261
77,5	244	2,5	18,32	B083	100LA/112MR	4	17480	4994
75,3	254	1,6	12,35	B063	112M/112MA	6	11170	3191
74,7	270	1,1	12,44	BA72	112M/112MA	6	6647	3323
70,7	270	1,6	13,15	B063	112M/112MA	6	11353	3244
64,5	296	2,0	14,43	B083	112M/112MA	6	18000	5265
64,0	312	1,1	22,19	BA72	100LA/112MR	4	7000	3500
63,4	298	1,4	22,39	B063	100LA/112MR	4	11686	3339
62,4	323	1,1	14,91	BA72	112M/112MA	6	7059	3530
62,2	304	2,0	22,82	B083	100LA/112MR	4	18000	5321
61,3	312	1,4	15,18	B063	112M/112MA	6	11773	3364
56,0	341	1,8	16,60	B083	112M/112MA	6	18000	5478
54,7	349	1,2	17,00	B063	112M/112MA	6	12000	3459
54,4	347	1,2	26,09	B063	100LA/112MR	4	12000	3468
53,2	356	1,7	26,71	B083	100LA/112MR	4	18000	5564
50,8	376	1,6	18,32	B083	112M/112MA	6	18000	5632
50,7	373	1,2	28,03	B063	100LA/112MR	4	12000	3529
48,8	391	2,6	19,06	B103	112M/112MA	6	22000	7116
48,1	393	1,6	29,50	B083	100LA/112MR	4	18000	5720
46,5	407	2,8	30,55	B103	100LA	4	22000	7224
44,7	423	1,4	31,80	B083	100LA/112MR	4	18000	5839
42,9	440	2,8	33,07	B103	100LA/112MR	4	22000	7396
41,2	459	1,3	34,49	B083	100LA/112MR	4	18000	5970
40,8	469	1,3	22,82	B083	112M/112MA	6	18000	5981
39,6	478	2,6	35,87	B103	100LA/112MR	4	22000	7577
39,2	487	2,1	23,70	B103	112M/112MA	6	22000	7592
35,9	527	1,2	39,60	B083	100LA/112MR	4	18000	6195
35,1	544	2,0	26,51	B103	112M/112MA	6	22000	7847
34,8	549	1,1	26,71	B083	112M/112MA	6	18000	6237
34,5	548	2,2	41,12	B103	100LA/112MR	4	22000	7887
33,1	572	1,1	42,95	B083	100LA/112MR	4	18000	6328
31,8	594	2,1	44,61	B103	100LA/112MR	4	22000	8076
31,5	606	1,0	29,50	B083	112M/112MA	6	18000	6399
31,3	605	1,0	45,44	B083	100LA/112MR	4	18000	6421
30,4	627	1,8	30,55	B103	112M/112MA	6	22000	8176
30,0	630	1,9	47,28	B103	100LA/112MR	4	22000	8213
28,3	669	2,2	50,24	B103	100LA/112MR	4	22000	8357

2,20 kW

n ₂ [rpm]	M ₂ [Nm]	f _s	i	Gear reducer	Motor		Fr ₂ D-S-P [N]	Fr ₂ C [N]
					Size	Pole		
28,1	679	1,8	33,07	B103	112M/112MA	6	22000	8363
27,7	682	1,1	51,19	B083	100LA/112MR	4	18000	6618
26,8	706	2,1	53,02	B103	100LA/112MR	4	22000	8486
26,3	719	1,0	55,52	B083	112MR	4	18000	6706
25,9	737	1,7	35,87	B103	112M/112MA	6	22000	8559
24,3	779	1,9	58,50	B103	100LA/112MR	4	22000	8725
22,9	832	2,4	40,53	B123	112M/112MA	6	30000	12446
22,7	833	3,4	62,59	B123	100LA	4	30000	12495
22,6	844	1,5	41,12	B103	112M/112MA	6	22000	8893
21,9	864	1,7	64,89	B103	100LA/112MR	4	22000	8981
20,8	916	1,3	44,61	B103	112M/112MA	6	22000	9095
20,7	913	1,6	68,58	B103	100LA/112MR	4	22000	9119
20,7	922	2,3	44,89	B123	112M/112MA	6	30000	12793
20,5	925	3,0	69,43	B123	100LA/112MR	4	30000	12849
19,7	971	1,3	47,28	B103	112M/112MA	6	22000	9241
19,5	969	1,5	72,76	B103	100LA/112MR	4	22000	9268
19,1	991	3,0	74,42	B123	100LA/112MR	4	30000	13087
18,7	1023	2,3	49,80	B123	112M/112MA	6	30000	13148
18,5	1032	1,4	50,24	B103	112M/112MA	6	22000	9394
18,0	1051	1,4	78,92	B103	100LA/112MR	4	22000	9475
17,7	1066	2,8	80,04	B123	100LA/112MR	4	30000	13339
17,5	1089	1,3	53,02	B103	112M/112MA	6	22000	9531
17,1	1115	2,4	54,30	B123	112M/112MA	6	30000	13446
17,0	1114	1,4	83,66	B103	100LA/112MR	4	22000	9623
15,9	1201	1,2	58,50	B103	112M/112MA	6	22000	9782
15,8	1197	2,5	89,87	B123	100LA/112MR	4	30000	13741
15,7	1219	2,2	59,36	B123	112M/112MA	6	30000	13755
15,4	1229	1,2	92,31	B103	100LA/112MR	4	22000	9877
15,1	1253	3,4	94,13	B143	100LA ⁽¹⁾	4	40000	40000
14,9	1285	2,2	62,59	B123	112M/112MA	6	30000	13938
14,3	1332	1,1	64,89	B103	112M/112MA	6	22000	10049
14,3	1332	3,2	64,88	B143	112MA	6	40000	40000
14,2	1328	2,3	99,70	B123	100LA/112MR	4	30000	14103
13,6	1408	1,0	68,58	B103	112M/112MA	6	22000	10192
13,5	1404	1,1	105,44	B103	100LA/112MR	4	22000	10222
13,4	1426	2,0	69,43	B123	112M/112MA	6	30000	14298
13,4	1409	3,0	105,83	B143	100LA/112MR	4	40000	40000
13,3	1420	2,1	106,65	B123	100LA/112MR	4	30000	14338
13,2	1447	1,0	72,76	B103	112M	6	22000	10263
13,2	1446	3,0	70,43	B143	112M/112MA	6	40000	40000
12,7	1491	2,9	111,94	B143	100LA/112MR	4	40000	40000
12,5	1528	2,0	74,42	B123	112M/112MA	6	30000	14538

⁽¹⁾ Available only with brake motor (TBS)

2,20 kW

n2 [rpm]	M2 [Nm]	fs	i	Gear reducer	Motor Size	Pole	Fr2 D-S-P [N]	Fr2 C [N]
12,4	1529	1,0	114,80	B103	100LA/112MR	4	22000	10443
12,1	1584	2,7	77,12	B143	112M/112MA	6	40000	40000
11,9	1593	1,9	119,60	B123	100LA/112MR	4	30000	14736
11,6	1644	1,8	80,04	B123	112M/112MA	6	30000	14789
11,4	1659	2,6	124,62	B143	100LA/112MR	4	40000	40000
10,9	1731	1,7	129,96	B123	100LA/112MR	4	30000	15022
10,9	1757	2,4	85,54	B143	112M/112MA	6	40000	40000
10,4	1817	2,4	136,44	B143	100LA/112MR	4	40000	40000
10,3	1845	1,6	89,87	B123	112M/112MA	6	30000	15184
9,9	1933	2,2	94,13	B143	112M/112MA	6	40000	40000
9,8	1923	1,6	144,43	B123	100LA/112MR	4	30000	15382
9,5	1992	2,1	149,59	B143	100LA/112MR	4	40000	40000
9,3	2047	1,5	99,70	B123	112M/112MA	6	30000	15533
8,9	2134	1,4	160,23	B123	100LA/112MR	4	30000	15730
8,8	2173	2,0	105,83	B143	112M/112MA	6	40000	40000
8,7	2190	1,4	106,65	B123	112M/112MA	6	30000	15755
8,5	2218	1,9	166,53	B143	100LA/112MR	4	40000	40000
8,3	2299	1,9	111,94	B143	112M/112MA	6	40000	40000
7,9	2402	1,2	180,40	B123	100LA/112MR	4	30000	16117
7,8	2456	1,2	119,60	B123	112M/112MA	6	30000	16124
7,6	2493	1,7	187,24	B143	100LA/112MR	4	40000	40000
7,5	2559	1,7	124,62	B143	112M/112MA	6	40000	40000
7,2	2669	1,1	129,96	B123	112M/112MA	6	30000	16382
6,8	2802	1,5	136,44	B143	112M/112MA	6	40000	40000
6,4	2966	1,0	144,43	B123	112M/112MA	6	30000	16697
6,2	3072	1,4	149,59	B143	112M/112MA	6	40000	40000
5,6	3420	1,2	166,53	B143	112M/112MA	6	40000	40000
5,0	3845	1,1	187,24	B143	112M/112MA	6	40000	40000

3,00 kW

n2 [rpm]	M2 [Nm]	fs	i	Gear reducer	Motor Size	Pole	Fr2 D-S-P [N]	Fr2 C [N]
248,5	104	2,0	5,71	B063	100LB/112MS	4	7836	2239
206,4	125	2,0	6,88	B063	100LB/112MS	4	8264	2361
193,9	133	1,9	7,32	B063	100LB/112MS	4	8412	2403
181,8	142	2,5	7,81	B083	100LB/112MS	4	13363	3818
169,9	160	1,9	8,36	BA72	100LB/112MS	4	5055	2528
164,7	157	2,7	8,62	B083	100LB/112MS	4	13767	3933
162,7	160	1,3	5,71	B063	112MB	6	8827	2522
155,0	166	1,9	9,16	B063	100LB/112MS	4	8953	2558
141,2	193	1,5	10,06	BA72	100LB/112MS	4	5377	2689
138,4	186	1,8	10,26	B063	100LB/112MS	4	9233	2638

3,00 kW

n2 [rpm]	M2 [Nm]	fs	i	Gear reducer	Motor Size	Pole	Fr2 D-S-P [N]	Fr2 C [N]
135,3	191	2,5	10,49	B083	100LB/112MS	4	14593	4170
135,2	193	1,3	6,88	B063	112MB	6	9282	2652
128,8	200	1,9	11,03	B063	100LB/112MS	4	9412	2689
127,0	205	1,2	7,32	B063	112MB	6	9437	2696
122,5	210	2,6	11,59	B083	100LB/112MS	4	15024	4293
119,1	219	1,6	7,81	B083	112MB/132S/132SA	6	15141	4326
114,9	224	1,8	12,35	B063	100LB/112MS	4	9697	2771
114,1	238	1,2	12,44	BA72	100LB/112MS	4	5772	2886
111,3	247	1,2	8,36	BA72	112MB	6	5821	2910
108,0	239	1,8	13,15	B063	100LB/112MS	4	9855	2816
107,9	241	1,8	8,62	B083	112MB/132S/132SA	6	15582	4452
101,5	257	1,3	9,16	B063	112MB	6	10000	2857
98,4	262	2,2	14,43	B083	100LB/112MS	4	16007	4573
95,3	286	1,3	14,91	BA72	100LB/112MS	4	6131	3065
93,6	276	1,5	15,18	B063	100LB/112MS	4	10218	2919
92,4	297	1,0	10,06	BA72	112MB	6	6192	3096
90,6	287	1,3	10,26	B063	112MB	6	10287	2939
88,6	294	1,6	10,49	B083	112MB/132S/132SA	6	16478	4708
85,6	301	2,0	16,60	B083	100LB/112MS	4	16654	4758
84,3	309	1,3	11,03	B063	112MB	6	10468	2991
83,5	309	1,4	17,00	B063	100LB/112MS	4	10507	3002
80,3	324	1,7	11,59	B083	112MB/132S/132SA	6	16942	4841
79,1	344	1,0	17,94	BA72	100LB/112MS	4	6521	3261
77,5	333	1,8	18,32	B083	100LB/112MS	4	17121	4892
75,3	346	1,2	12,35	B063	112MB	6	10754	3073
70,7	368	1,2	13,15	B063	112MB	6	10910	3117
64,5	404	1,4	14,43	B083	112MB/132S/132SA	6	17990	5140
63,4	407	1,1	22,39	B063	100LB/112MS	4	11197	3199
62,2	414	1,5	22,82	B083	100LB/112MS	4	18000	5193
61,3	425	1,0	15,18	B063	112MB	6	11262	3218
59,9	430	2,3	23,70	B103	100LB/112MS	4	22000	6597
56,0	465	1,3	16,60	B083	112MB/132S/132SA	6	18000	5335
53,9	484	2,1	17,27	B103	112MB/132S/132SA	6	22000	6802
53,6	481	2,2	26,51	B103	100LB/112MS	4	22000	6817
53,2	485	1,3	26,71	B083	100LB/112MS	4	18000	5415
50,8	513	1,2	18,32	B083	112MB/132S/132SA	6	18000	5474
48,8	534	1,9	19,06	B103	112MB/132S/132SA	6	22000	6999
48,1	536	1,1	29,50	B083	100LB/112MS	4	18000	5555
46,5	555	2,1	30,55	B103	100LB/112MS	4	22000	7103
44,7	577	1,1	31,80	B083	100LB/112MS	4	18000	5661
42,9	600	2,0	33,07	B103	100LB/112MS	4	22000	7265
39,6	651	1,9	35,87	B103	100LB/112MS	4	22000	7434

3,00 kW

n2 [rpm]	M2 [Nm]	fs	i	Gear reducer	Motor Size	Pole	Fr2 D-S-P [N]	Fr2 C [N]
39,2	664	1,5	23,70	B103	112MB/132S/132SA	6	22000	7447
35,1	742	1,5	26,51	B103	112MB/132S/132SA	6	22000	7684
35,0	736	2,7	40,53	B123	100LB/112MS	4	30000	10808
34,9	746	2,7	27,51	B123	132S/132SA	6	30000	10809
34,5	747	1,6	41,12	B103	100LB/112MS	4	22000	7723
31,8	810	1,5	44,61	B103	100LB/112MS	4	22000	7898
31,6	815	2,7	44,89	B123	100LB/112MS	4	30000	11107
31,2	835	2,4	30,79	B123	132S/132SA	6	30000	11139
30,4	856	1,3	30,55	B103	112MB/132S/132SA	6	22000	7988
30,0	859	1,4	47,28	B103	100LB/112MS	4	22000	8025
29,7	875	2,3	31,26	B123	112MB/132S/132SA	6	30000	11278
28,5	904	2,6	49,80	B123	100LB/112MS	4	30000	11415
28,3	912	1,6	50,24	B103	100LB/112MS	4	22000	8157
28,1	926	1,3	33,07	B103	112MB/132S/132SA	6	22000	8160
26,8	963	1,5	53,02	B103	100LB/112MS	4	22000	8275
26,8	971	2,1	34,68	B123	112MB/132S/132SA	6	30000	11585
26,2	986	2,8	54,30	B123	100LB/112MS	4	30000	11672
25,9	1004	1,2	35,87	B103	112MB/132S/132SA	6	22000	8339
24,3	1062	1,4	58,50	B103	100LB/112MS	4	22000	8493
23,9	1078	2,5	59,36	B123	100LB/112MS	4	30000	11938
22,9	1135	1,8	40,53	B123	112MB/132S/132SA	6	30000	12048
22,7	1136	2,5	62,59	B123	100LB/112MS	4	30000	12097
22,6	1152	1,1	41,12	B103	112MB/132S/132SA	6	22000	8640
21,9	1178	1,2	64,89	B103	100LB/112MS	4	22000	8723
21,5	1210	1,0	44,61	B103	132S/132SA	6	22000	8751
20,7	1245	1,2	68,58	B103	100LB/112MS	4	22000	8846
20,7	1257	1,7	44,89	B123	112MB/132S/132SA	6	30000	12352
20,5	1261	2,2	69,43	B123	100LB/112MS	4	30000	12407
20,2	1279	3,3	70,43	B143	100LB/112MS	4	40000	40000
19,5	1321	1,1	72,76	B103	100LB/112MS	4	22000	8979
19,2	1354	2,7	48,35	B143	112MB	6	40000	40000
19,1	1351	2,2	74,42	B123	100LB/112MS	4	30000	12614
18,7	1395	1,7	49,80	B123	112MB/132S/132SA	6	30000	12660
18,5	1407	1,0	50,24	B103	112MB/132S/132SA	6	22000	9086
18,4	1400	3,0	77,12	B143	100LB/112MS	4	40000	40000
18,1	1438	1,0	53,02	B103	132S/132SA	6	22000	9135
18,0	1433	1,0	78,92	B103	100LB/112MS	4	22000	9161
17,7	1453	2,1	80,04	B123	100LB/112MS	4	30000	12830
17,5	1489	2,9	53,16	B143	112MB/132S/132SA	6	40000	40000
17,1	1521	1,8	54,30	B123	112MB/132S/132SA	6	30000	12914
17,0	1519	1,0	83,66	B103	100LB/112MS	4	22000	9291
17,0	1530	2,8	54,63	B143	112MB/132S/132SA	6	40000	40000

6.1 B/BA GEARED MOTORS (50Hz)

3,00 kW

n2 [rpm]	M2 [Nm]	fs	i	Gear reducer	Motor		Fr2 D-S-P [N]	Fr2 C [N]
					Size	Pole		
16,6	1553	2,7	85,54	B143	100LB/112MS	4	40000	40000
15,8	1632	1,8	89,87	B123	100LB/112MS	4	30000	13169
15,8	1653	2,6	59,02	B143	112MB/132S/132SA	6	40000	40000
15,7	1662	1,6	59,36	B123	112MB/132S/132SA	6	30000	13172
15,1	1709	2,5	94,13	B143	100LB/112MS	4	40000	40000
14,9	1753	1,6	62,59	B123	112MB/132S/132SA	6	30000	13324
14,3	1817	2,4	64,88	B143	112MB/132S/132SA	6	40000	40000
14,2	1810	1,7	99,70	B123	100LB/112MS	4	30000	13469
13,4	1944	1,4	69,43	B123	112MB/132S/132SA	6	30000	13617
13,4	1922	2,2	105,83	B143	100LB/112MS	4	40000	40000
13,3	1937	1,5	106,65	B123	100LB/112MS	4	30000	13659
13,2	1972	2,2	70,43	B143	112MB/132S/132SA	6	40000	40000
12,7	2033	2,1	111,94	B143	100LB/112MS	4	40000	40000
12,5	2084	1,4	74,42	B123	112MB/132S/132SA	6	30000	13808
12,1	2160	2,0	77,12	B143	112MB/132S/132SA	6	40000	40000
11,9	2172	1,4	119,60	B123	100LB/112MS	4	30000	13975
11,6	2241	1,3	80,04	B123	112MB/132S/132SA	6	30000	14004
11,4	2263	1,9	124,62	B143	100LB/112MS	4	40000	40000
11,4	2276	3,0	83,89	B153	132S/132SA	6	65000	65000
11,0	2378	2,9	87,65	B153	132S/132SA	6	65000	65000
10,9	2360	1,3	129,96	B123	100LB/112MS	4	30000	14196
10,9	2396	1,8	85,54	B143	112MB/132S/132SA	6	40000	40000
10,4	2478	1,7	136,44	B143	100LB/112MS	4	40000	40000
10,3	2517	1,2	89,87	B123	112MB/132S/132SA	6	30000	14303
10,3	2524	2,7	93,05	B153	132S/132SA	6	65000	65000
9,9	2636	1,6	94,13	B143	112MB/132S/132SA	6	40000	40000
9,8	2623	1,1	144,43	B123	100LB/112MS	4	30000	14464
9,5	2716	1,6	149,59	B143	100LB/112MS	4	40000	40000
9,3	2792	1,1	99,70	B123	112MB/132S/132SA	6	30000	14555
9,3	2797	2,4	103,12	B153	132S/132SA	6	65000	65000
8,9	2909	1,0	160,23	B123	100LB/112MS	4	30000	14711
8,8	2964	1,4	105,83	B143	112MB/132S/132SA	6	40000	40000
8,7	2987	1,0	106,65	B123	112MB/132S/132SA	6	30000	14709
8,5	3024	1,4	166,53	B143	100LB/112MS	4	40000	40000
8,3	3135	1,4	111,94	B143	112MB/132S/132SA	6	40000	40000
7,7	3361	2,0	123,88	B153	132S/132SA	6	65000	65000
7,6	3400	1,3	187,24	B143	100LB/112MS	4	40000	40000
7,5	3490	1,2	124,62	B143	112MB/132S/132SA	6	40000	40000
7,2	3642	1,9	134,27	B153	132S/132SA	6	65000	65000
6,8	3821	1,1	136,44	B143	112MB/132S/132SA	6	40000	40000
6,4	4049	1,7	149,26	B153	132S/132SA	6	65000	65000
6,2	4189	1,0	149,59	B143	112MB/132S/132SA	6	40000	40000

6.1 B/BA GEARED MOTORS (50Hz)

3,00 kW

n2 [rpm]	M2 [Nm]	fs	i	Gear reducer	Motor Size	Pole	Fr2 D-S-P [N]	Fr2 C [N]
5,8	4487	1,5	165,42	B153	132S/132SA	6	65000	65000

4,00 kW

n2 [rpm]	M2 [Nm]	fs	i	Gear reducer	Motor Size	Pole	Fr2 D-S-P [N]	Fr2 C [N]
253,7	136	1,5	5,71	B063	112M/112MA	4	7635	2182
209,3	164	1,5	6,88	B063	112M/112MA	4	8046	2299
196,6	175	1,4	7,32	B063	112M/112MA	4	8182	2338
184,4	186	1,9	7,81	B083	112M/112MA	4	13119	3748
172,3	211	1,4	8,36	BA72	112M/112MA	4	5032	2516
167,0	206	2,1	8,62	B083	112M/112MA	4	13501	3857
157,2	219	1,4	9,16	B063	112M/112MA	4	8671	2478
143,1	254	1,2	10,06	BA72	112M/112MA	4	5352	2676
140,3	245	1,4	10,26	B063	112M/112MA	4	8922	2549
137,2	251	1,9	10,49	B083	112M/112MA	4	14280	4080
130,6	263	1,5	11,03	B063	112M/112MA	4	9080	2594
124,3	277	2,0	11,59	B083	112M/112MA	4	14683	4195
122,9	282	1,3	7,81	B083	132MA	6	14716	4205
116,6	295	1,4	12,35	B063	112M/112MA	4	9329	2666
111,3	312	1,4	8,62	B083	132MA	6	15124	4321
109,5	314	1,4	13,15	B063	112M/112MA	4	9466	2704
99,8	344	1,7	14,43	B083	112M/112MA	4	15595	4456
94,9	362	1,2	15,18	B063	112M/112MA	4	9774	2793
91,5	380	1,2	10,49	B083	132MA	6	15948	4556
86,8	396	1,5	16,60	B083	112M/112MA	4	16188	4625
84,7	406	1,1	17,00	B063	112M/112MA	4	10013	2861
83,4	412	2,4	17,27	B103	112M/112MA	4	20628	5894
82,9	419	1,3	11,59	B083	132MA	6	16369	4677
78,6	437	1,4	18,32	B083	112M/112MA	4	16612	4746
75,6	455	2,2	19,06	B103	112M/112MA	4	21225	6064
66,5	522	1,1	14,43	B083	132MA	6	17309	4945
63,1	545	1,1	22,82	B083	112M/112MA	4	17558	5017
62,4	556	2,7	15,38	B123	132MA	6	30000	9001
60,8	566	1,8	23,70	B103	112M/112MA	4	22000	6454
57,8	600	1,0	16,60	B083	132MA	6	17909	5117
55,6	625	1,6	17,27	B103	132MA	6	22000	6612
54,3	633	1,7	26,51	B103	112M/112MA	4	22000	6659
51,7	672	2,4	18,58	B123	132MA	6	30000	9474
50,4	689	1,5	19,06	B103	132MA	6	22000	6794
47,1	729	1,6	30,55	B103	112M/112MA	4	22000	6924
46,6	745	2,4	20,61	B123	132MA	6	30000	9739
46,1	746	2,7	31,26	B123	112M/112MA	4	30000	9777

6.1 B/BA GEARED MOTORS (50Hz)

4,00 kW

n2 [rpm]	M2 [Nm]	fs	i	Gear reducer	Motor		Fr2 D-S-P [N]	Fr2 C [N]
					Size	Pole		
43,5	789	1,6	33,07	B103	112M/112MA	4	22000	7074
42,1	824	2,5	22,78	B123	132MA	6	30000	9996
41,5	828	2,4	34,68	B123	112M/112MA	4	30000	10045
40,5	857	1,2	23,70	B103	132MA	6	22000	7205
40,1	856	1,4	35,87	B103	112M/112MA	4	22000	7229
37,1	936	2,2	25,89	B123	132MA	6	30000	10326
36,2	959	1,1	26,51	B103	132MA	6	22000	7420
35,5	968	2,1	40,53	B123	112M/112MA	4	30000	10449
35,0	982	1,2	41,12	B103	112M/112MA	4	22000	7492
34,9	995	2,0	27,51	B123	132MA	6	30000	10483
32,3	1065	1,2	44,61	B103	112M/112MA	4	22000	7649
32,1	1072	2,0	44,89	B123	112M/112MA	4	30000	10714
31,4	1105	1,0	30,55	B103	132MA	6	22000	7693
31,2	1114	1,8	30,79	B123	132MA	6	30000	10774
30,7	1131	1,8	31,26	B123	132MA	6	30000	10813
30,5	1129	1,1	47,28	B103	112M/112MA	4	22000	7762
29,0	1196	1,0	33,07	B103	132MA	6	22000	7845
28,9	1189	1,9	49,80	B123	112M/112MA	4	30000	10983
28,7	1199	1,2	50,24	B103	112M/112MA	4	22000	7880
27,7	1255	1,6	34,68	B123	132MA	6	30000	11079
27,2	1266	1,1	53,02	B103	112M/112MA	4	22000	7984
27,1	1269	3,4	53,16	B143	112M/112MA	4	37978	37978
26,5	1296	2,1	54,30	B123	112M/112MA	4	30000	11205
26,4	1304	3,3	54,63	B143	112M/112MA	4	38246	38246
26,2	1326	2,6	36,67	B143	132MA	6	38273	38273
24,6	1397	1,0	58,50	B103	112M/112MA	4	22000	8175
24,4	1409	3,0	59,02	B143	112M/112MA	4	39007	39007
24,3	1417	1,9	59,36	B123	112M/112MA	4	30000	11431
23,8	1457	2,4	40,29	B143	132MA	6	39195	39195
23,7	1466	1,4	40,53	B123	132MA	6	30000	11472
23,0	1494	1,9	62,59	B123	112M/112MA	4	30000	11564
22,2	1549	2,8	64,88	B143	112M/112MA	4	39942	39942
21,7	1597	2,2	44,16	B143	132MA	6	40000	40000
21,4	1624	1,3	44,89	B123	132MA	6	30000	11725
20,7	1658	1,7	69,43	B123	112M/112MA	4	30000	11821
20,4	1682	2,5	70,43	B143	112M/112MA	4	40000	40000
19,9	1749	2,1	48,35	B143	132MA	6	40000	40000
19,4	1777	1,7	74,42	B123	112M/112MA	4	30000	11989
19,3	1801	1,3	49,80	B123	132MA	6	30000	11975
18,7	1841	2,3	77,12	B143	112M/112MA	4	40000	40000
18,1	1923	2,2	53,16	B143	132MA	6	40000	40000
18,0	1911	1,6	80,04	B123	112M/112MA	4	30000	12161

6.1 B/BA GEARED MOTORS (50Hz)

4,00 kW

n2 [rpm]	M2 [Nm]	fs	i	Gear reducer	Motor Size	Pole	Fr2 D-S-P [N]	Fr2 C [N]
17,7	1964	1,4	54,30	B123	132MA	6	30000	12176
17,6	1976	2,2	54,63	B143	132MA	6	40000	40000
16,8	2042	2,1	85,54	B143	112M/112MA	4	40000	40000
16,3	2135	2,0	59,02	B143	132MA	6	40000	40000
16,2	2147	1,3	59,36	B123	132MA	6	30000	12376
16,0	2146	1,4	89,87	B123	112M/112MA	4	30000	12424
15,8	2204	3,1	60,92	B153	132MA	6	65000	65000
15,3	2264	1,2	62,59	B123	132MA	6	30000	12490
15,3	2247	1,9	94,13	B143	112M/112MA	4	40000	40000
15,1	2296	3,0	63,47	B153	132MA	6	65000	65000
14,8	2347	1,8	64,88	B143	132MA	6	40000	40000
14,4	2380	1,3	99,70	B123	112M/112MA	4	30000	12647
13,8	2511	1,1	69,43	B123	132MA	6	30000	12704
13,6	2548	1,7	70,43	B143	132MA	6	40000	40000
13,6	2527	1,7	105,83	B143	112M/112MA	4	40000	40000
13,5	2546	1,2	106,65	B123	112M/112MA	4	30000	12784
13,5	2573	2,7	71,15	B153	132MA	6	65000	65000
12,9	2692	1,1	74,42	B123	132MA	6	30000	12838
12,9	2673	1,6	111,94	B143	112M/112MA	4	40000	40000
12,4	2789	1,5	77,12	B143	132MA	6	40000	40000
12,4	2793	2,4	77,22	B153	132MA	6	65000	65000
12,0	2895	1,0	80,04	B123	132MA	6	30000	12969
12,0	2855	1,0	119,60	B123	112M/112MA	4	30000	13000
11,6	2975	1,4	124,62	B143	112M/112MA	4	40000	40000
11,4	3034	2,3	83,89	B153	132MA	6	65000	65000
11,2	3094	1,4	85,54	B143	132MA	6	40000	40000
11,0	3170	2,2	87,65	B153	132MA	6	65000	65000
10,6	3257	1,3	136,44	B143	112M/112MA	4	40000	40000
10,3	3366	2,0	93,05	B153	132MA	6	65000	65000
10,2	3405	1,3	94,13	B143	132MA	6	40000	40000
9,6	3571	1,2	149,59	B143	112M/112MA	4	40000	40000
9,3	3730	1,8	103,12	B153	132MA	6	65000	65000
9,1	3828	1,1	105,83	B143	132MA	6	40000	40000
8,6	4049	1,1	111,94	B143	132MA	6	40000	40000
8,6	3976	1,1	166,53	B143	112M/112MA	4	40000	40000
7,7	4481	1,5	123,88	B153	132MA	6	65000	65000
7,2	4856	1,4	134,27	B153	132MA	6	65000	65000
6,4	5399	1,3	149,26	B153	132MA	6	65000	65000
5,8	5983	1,1	165,42	B153	132MA	6	65000	65000

4,80 kW

n2 [rpm]	M2 [Nm]	fs	i	Gear reducer	Motor Size	Pole	Fr2 D-S-P [N]	Fr2 C [N]
250,2	165	1,3	5,71	B063	112MB ⁽¹⁾	4	7541	2155
207,9	198	1,2	6,88	B063	112MB ⁽¹⁾	4	7912	2261
195,3	211	1,2	7,32	B063	112MB ⁽¹⁾	4	8038	2297
183,1	225	1,6	7,81	B083	112MB ⁽¹⁾	4	12993	3712
171,1	255	1,2	8,36	BA72	112MB ⁽¹⁾	4	5043	2522
165,8	249	1,7	8,62	B083	112MB ⁽¹⁾	4	13361	3817
156,1	264	1,2	9,16	B063	112MB ⁽¹⁾	4	8488	2425
139,3	296	1,1	10,26	B063	112MB ⁽¹⁾	4	8714	2490
136,3	303	1,5	10,49	B083	112MB ⁽¹⁾	4	14104	4030
129,7	318	1,2	11,03	B063	112MB ⁽¹⁾	4	8856	2530
123,4	334	1,6	11,59	B083	112MB ⁽¹⁾	4	14486	4139
115,7	356	1,1	12,35	B063	112MB ⁽¹⁾	4	9076	2593
108,7	379	1,1	13,15	B063	112MB ⁽¹⁾	4	9195	2627
99,1	416	1,4	14,43	B083	112MB ⁽¹⁾	4	15343	4384
86,2	479	1,3	16,60	B083	112MB ⁽¹⁾	4	15895	4541
82,8	498	2,0	17,27	B103	112MB ⁽¹⁾	4	20431	5837
78,0	529	1,2	18,32	B083	112MB ⁽¹⁾	4	16286	4653
75,0	550	1,8	19,06	B103	112MB ⁽¹⁾	4	21005	6001
60,3	684	1,5	23,70	B103	112MB ⁽¹⁾	4	22000	6373
55,2	747	2,7	25,89	B123	112MB ⁽¹⁾	4	30000	9151
53,9	765	1,4	26,51	B103	112MB ⁽¹⁾	4	22000	6568
46,8	882	1,3	30,55	B103	112MB ⁽¹⁾	4	22000	6817
45,7	902	2,2	31,26	B123	112MB ⁽¹⁾	4	30000	9598
43,2	954	1,3	33,07	B103	112MB ⁽¹⁾	4	22000	6956
41,2	1001	2,0	34,68	B123	112MB ⁽¹⁾	4	30000	9844
39,9	1035	1,2	35,87	B103	112MB ⁽¹⁾	4	22000	7101
35,3	1169	1,7	40,53	B123	112MB ⁽¹⁾	4	30000	10211
34,8	1186	1,0	41,12	B103	112MB ⁽¹⁾	4	22000	7343
32,4	1274	2,7	44,16	B143	112MB ⁽¹⁾	4	35559	35559
31,9	1295	1,7	44,89	B123	112MB ⁽¹⁾	4	30000	10449
29,6	1395	2,6	48,35	B143	112MB ⁽¹⁾	4	36376	36376
28,7	1437	1,6	49,80	B123	112MB ⁽¹⁾	4	30000	10686
28,5	1449	1,0	50,24	B103	112MB ⁽¹⁾	4	22000	7695
26,9	1534	2,8	53,16	B143	112MB ⁽¹⁾	4	37231	37231
26,3	1567	1,7	54,30	B123	112MB ⁽¹⁾	4	30000	10880
26,2	1576	2,7	54,63	B143	112MB ⁽¹⁾	4	37477	37477
24,2	1703	2,5	59,02	B143	112MB ⁽¹⁾	4	38170	38170
24,1	1712	1,6	59,36	B123	112MB ⁽¹⁾	4	30000	11074
22,8	1806	1,6	62,59	B123	112MB ⁽¹⁾	4	30000	11186
22,0	1872	2,3	64,88	B143	112MB ⁽¹⁾	4	39016	39016
20,6	2003	1,4	69,43	B123	112MB ⁽¹⁾	4	30000	11400
20,3	2032	2,1	70,43	B143	112MB ⁽¹⁾	4	39740	39740

⁽¹⁾ Available only with brake motor (TBS)

4,80 kW

n2 [rpm]	M2 [Nm]	fs	i	Gear reducer	Motor Size	Pole	Fr2 D-S-P [N]	Fr2 C [N]
19,2	2147	1,4	74,42	B123	112MB ⁽¹⁾	4	30000	11535
18,5	2225	1,9	77,12	B143	112MB ⁽¹⁾	4	40000	40000
17,9	2309	1,3	80,04	B123	112MB ⁽¹⁾	4	30000	11672
16,7	2468	1,7	85,54	B143	112MB ⁽¹⁾	4	40000	40000
15,9	2593	1,2	89,87	B123	112MB ⁽¹⁾	4	30000	11872
15,2	2716	1,6	94,13	B143	112MB ⁽¹⁾	4	40000	40000
14,3	2876	1,0	99,70	B123	112MB ⁽¹⁾	4	30000	12032
13,5	3053	1,4	105,83	B143	112MB ⁽¹⁾	4	40000	40000
12,8	3229	1,3	111,94	B143	112MB ⁽¹⁾	4	40000	40000
11,5	3595	1,2	124,62	B143	112MB ⁽¹⁾	4	40000	40000
10,5	3936	1,1	136,44	B143	112MB ⁽¹⁾	4	40000	40000

5,50 kW

n2 [rpm]	M2 [Nm]	fs	i	Gear reducer	Motor Size	Pole	Fr2 D-S-P [N]	Fr2 C [N]
185,7	255	1,4	7,81	B083	132MS/132S	4	12811	3660
168,2	281	1,5	8,62	B083	132MS/132S	4	13164	3761
138,2	342	1,4	10,49	B083	132MS/132S	4	13875	3964
125,1	378	1,4	11,59	B083	132MS/132S	4	14238	4068
120,5	396	2,7	7,97	B123	132MB	6	25591	7312
111,3	429	1,0	8,62	B083	132MB	6	14651	4186
100,5	470	1,2	14,43	B083	132MS/132S	4	15046	4299
99,8	478	2,7	9,62	B123	132MB	6	26973	7707
87,4	541	1,1	16,60	B083	132MS/132S	4	15561	4446
84,0	563	1,8	17,27	B103	132MS/132S	4	20145	5756
79,1	597	1,0	18,32	B083	132MS/132S	4	15923	4550
78,1	606	2,6	18,58	B123	132MS/132S	4	28852	8244
76,9	621	2,3	12,48	B123	132MB	6	28936	8267
76,1	621	1,6	19,06	B103	132MS/132S	4	20696	5913
70,4	672	2,7	20,61	B123	132MS/132S	4	29651	8472
69,3	689	2,2	13,84	B123	132MB	6	29732	8495
63,7	743	2,7	22,78	B123	132MS/132S	4	30000	8693
62,4	765	2,0	15,38	B123	132MB	6	30000	8727
61,2	773	1,3	23,70	B103	132MS/132S	4	21938	6268
56,3	848	2,7	17,04	B143	132MB	6	30302	30302
56,0	844	2,4	25,89	B123	132MS/132S	4	30000	8977
55,6	859	1,2	17,27	B103	132MB	6	22000	6419
54,7	864	1,2	26,51	B103	132MS/132S	4	22000	6453
52,7	897	2,3	27,51	B123	132MS/132S	4	30000	9112
51,7	924	1,7	18,58	B123	132MB	6	30000	9143
50,4	948	1,1	19,06	B103	132MB	6	22000	6581
47,5	996	1,2	30,55	B103	132MS/132S	4	22000	6688

⁽¹⁾ Available only with brake motor (TBS)

6.1 B/BA GEARED MOTORS (50Hz)

5,50 kW

n2 [rpm]	M2 [Nm]	fs	i	Gear reducer	Motor Size	Pole	Fr2 D-S-P [N]	Fr2 C [N]
47,1	1004	2,0	30,79	B123	132MS/132S	4	30000	9361
46,6	1025	1,8	20,61	B123	132MB	6	30000	9372
46,4	1019	2,0	31,26	B123	132MS/132S	4	30000	9395
43,9	1078	1,1	33,07	B103	132MS/132S	4	22000	6819
42,1	1133	1,8	22,78	B123	132MB	6	30000	9590
41,8	1131	1,8	34,68	B123	132MS/132S	4	30000	9622
40,4	1169	1,0	35,87	B103	132MS/132S	4	22000	6954
37,5	1275	2,6	25,63	B143	132MB	6	33697	33697
37,1	1288	1,6	25,89	B123	132MB	6	30000	9865
36,0	1314	2,6	40,29	B143	132MS/132S	4	34076	34076
35,8	1321	1,5	40,53	B123	132MS/132S	4	30000	9958
35,0	1365	2,4	27,44	B143	132MB	6	34272	34272
34,9	1368	1,5	27,51	B123	132MB	6	30000	9993
32,8	1440	2,4	44,16	B143	132MS/132S	4	34849	34849
32,3	1464	1,5	44,89	B123	132MS/132S	4	30000	10172
32,0	1494	2,3	30,05	B143	132MB	6	35031	35031
31,2	1531	1,3	30,79	B123	132MB	6	30000	10225
30,7	1555	1,3	31,26	B123	132MB	6	30000	10256
30,0	1576	2,3	48,35	B143	132MS/132S	4	35611	35611
29,1	1624	1,4	49,80	B123	132MS/132S	4	30000	10383
29,1	1642	2,1	33,01	B143	132MB	6	35816	35816
27,7	1725	1,2	34,68	B123	132MB	6	30000	10461
27,3	1733	2,5	53,16	B143	132MS/132S	4	36402	36402
26,7	1770	1,5	54,30	B123	132MS/132S	4	30000	10553
26,5	1781	2,4	54,63	B143	132MS/132S	4	36628	36628
26,2	1824	1,9	36,67	B143	132MB	6	36686	36686
24,6	1924	2,2	59,02	B143	132MS/132S	4	37265	37265
24,4	1935	1,4	59,36	B123	132MS/132S	4	30000	10721
23,8	2004	1,7	40,29	B143	132MB	6	37452	37452
23,7	2016	1,0	40,53	B123	132MB	6	30000	10750
23,2	2040	1,4	62,59	B123	132MS/132S	4	30000	10816
22,8	2069	3,3	63,47	B153	132MS/132S	4	65000	65000
22,7	2104	2,8	42,30	B153	132MB	6	65000	65000
22,3	2115	2,0	64,88	B143	132MS/132S	4	38034	38034
21,7	2196	1,6	44,16	B143	132MB	6	38186	38186
20,9	2264	1,2	69,43	B123	132MS/132S	4	30000	10993
20,6	2296	1,9	70,43	B143	132MS/132S	4	38686	38686
20,4	2319	2,9	71,15	B153	132MS/132S	4	65000	65000
20,2	2364	2,4	47,53	B153	132MB	6	65000	65000
19,9	2405	1,5	48,35	B143	132MB	6	38893	38893
19,5	2426	1,2	74,42	B123	132MS/132S	4	30000	11103
19,0	2515	2,7	50,56	B153	132MB	6	65000	65000

6.1 B/BA GEARED MOTORS (50Hz)

5,50 kW

n2 [rpm]	M2 [Nm]	fs	i	Gear reducer	Motor Size	Pole	Fr2 D-S-P [N]	Fr2 C [N]
18,8	2514	1,7	77,12	B143	132MS/132S	4	39388	39388
18,8	2518	2,7	77,22	B153	132MS/132S	4	65000	65000
18,1	2609	1,1	80,04	B123	132MS/132S	4	30000	11210
18,1	2644	1,6	53,16	B143	132MB	6	39610	39610
17,7	2701	1,0	54,30	B123	132MB	6	30000	11209
17,6	2717	1,6	54,63	B143	132MB	6	39811	39811
17,6	2718	2,5	54,64	B153	132MB	6	65000	65000
17,3	2735	2,5	83,89	B153	132MS/132S	4	65000	65000
17,0	2789	1,5	85,54	B143	132MS/132S	4	40000	40000
16,8	2848	2,4	57,27	B153	132MB	6	65000	65000
16,5	2858	2,4	87,65	B153	132MS/132S	4	65000	65000
16,3	2935	1,5	59,02	B143	132MB	6	40000	40000
16,1	2930	1,0	89,87	B123	132MS/132S	4	30000	11360
15,8	3030	2,3	60,92	B153	132MB	6	65000	65000
15,6	3033	2,3	93,05	B153	132MS/132S	4	65000	65000
15,4	3069	1,4	94,13	B143	132MS/132S	4	40000	40000
15,1	3157	2,2	63,47	B153	132MB	6	65000	65000
14,8	3227	1,3	64,88	B143	132MB	6	40000	40000
14,1	3362	2,0	103,12	B153	132MS/132S	4	65000	65000
13,7	3450	1,2	105,83	B143	132MS/132S	4	40000	40000
13,6	3503	1,2	70,43	B143	132MB	6	40000	40000
13,5	3538	1,9	71,15	B153	132MB	6	65000	65000
13,0	3649	1,2	111,94	B143	132MS/132S	4	40000	40000
12,4	3835	1,1	77,12	B143	132MB	6	40000	40000
12,4	3841	1,8	77,22	B153	132MB	6	65000	65000
11,7	4039	1,7	123,88	B153	132MS/132S	4	65000	65000
11,6	4063	1,1	124,62	B143	132MS/132S	4	40000	40000
11,4	4172	1,6	83,89	B153	132MB	6	65000	65000
11,2	4255	1,0	85,54	B143	132MB	6	40000	40000
11,0	4359	1,6	87,65	B153	132MB	6	65000	65000
10,8	4377	1,6	134,27	B153	132MS/132S	4	65000	65000
10,3	4628	1,5	93,05	B153	132MB	6	65000	65000
9,7	4866	1,4	149,26	B153	132MS/132S	4	65000	65000
9,3	5128	1,3	103,12	B153	132MB	6	65000	65000
8,8	5393	1,3	165,42	B153	132MS/132S	4	65000	65000
7,7	6161	1,1	123,88	B153	132MB	6	65000	65000
7,2	6678	1,0	134,27	B153	132MB	6	65000	65000

7,50 kW

n2 [rpm]	M2 [Nm]	fs	i	Gear reducer	Motor Size	Pole	Fr2 D-S-P [N]	Fr2 C [N]
185,7	347	1,0	7,81	B083	132MA/132M	4	12437	3553

6.1 B/BA GEARED MOTORS (50Hz)

7,50 kW

n ₂ [rpm]	M ₂ [Nm]	f _s	i	Gear reducer	Motor		Fr ₂ D-S-P [N]	Fr ₂ C [N]
					Size	Pole		
168,2	383	1,1	8,62	B083	132MA/132M	4	12750	3643
138,2	467	1,0	10,49	B083	132MA/132M	4	13371	3820
125,1	515	1,0	11,59	B083	132MA/132M	4	13682	3909
121,8	535	2,0	7,97	B123	160M	6	24861	7103
116,2	555	2,4	12,48	B123	132MA/132M	4	25194	7198
104,7	615	2,3	13,84	B123	132MA/132M	4	25882	7395
100,8	646	2,0	9,62	B123	160M	6	26105	7459
94,3	684	2,2	15,38	B123	132MA/132M	4	26583	7595
93,9	694	2,1	10,33	B123	160M	6	26580	7594
84,0	768	1,3	17,27	B103	132MA/132M	4	19556	5587
78,1	826	1,9	18,58	B123	132MA/132M	4	27840	7954
77,7	838	1,7	12,48	B123	160M	6	27830	7952
76,1	847	1,2	19,06	B103	132MA/132M	4	20046	5727
70,4	916	2,0	20,61	B123	132MA/132M	4	28528	8151
70,1	929	1,6	13,84	B123	160M	6	28513	8147
67,0	972	2,3	14,49	B143	160M	6	28074	28074
63,7	1013	2,0	22,78	B123	132MA/132M	4	29185	8338
63,1	1032	1,5	15,38	B123	160M	6	29198	8342
56,9	1144	2,0	17,04	B143	160M	6	29244	29244
56,0	1151	1,8	25,89	B123	132MA/132M	4	30000	8574
52,8	1220	2,7	27,44	B143	132MA/132M	4	29819	29819
52,7	1223	1,7	27,51	B123	132MA/132M	4	30000	8683
52,2	1247	1,3	18,58	B123	160M	6	30000	8684
52,0	1252	2,1	18,66	B143	160M	6	29897	29897
48,3	1336	2,5	30,05	B143	132MA/132M	4	30474	30474
47,1	1383	1,3	20,61	B123	160M	6	30000	8864
47,1	1369	1,5	30,79	B123	132MA/132M	4	30000	8882
46,4	1390	1,5	31,26	B123	132MA/132M	4	30000	8908
46,2	1409	2,1	21,00	B143	160M	6	30743	30743
43,9	1467	2,3	33,01	B143	132MA/132M	4	31149	31149
42,6	1529	1,3	22,78	B123	160M	6	30000	9032
42,6	1529	2,1	22,77	B143	160M	6	31320	31320
41,8	1542	1,3	34,68	B123	132MA/132M	4	30000	9082
39,5	1630	2,1	36,67	B143	132MA/132M	4	31895	31895
37,8	1720	1,9	25,63	B143	160M	6	32147	32147
37,5	1738	1,2	25,89	B123	160M	6	30000	9234
36,0	1791	1,9	40,29	B143	132MA/132M	4	32552	32552
35,8	1802	1,1	40,53	B123	132MA/132M	4	30000	9327
35,3	1846	1,1	27,51	B123	160M	6	30000	9324
35,3	1842	1,8	27,44	B143	160M	6	32618	32618
32,8	1963	1,8	44,16	B143	132MA/132M	4	33179	33179
32,3	1996	1,1	44,89	B123	132MA/132M	4	30000	9473

6.1 B/BA GEARED MOTORS (50Hz)

7,50 kW

n2 [rpm]	M2 [Nm]	fs	i	Gear reducer	Motor		Fr2 D-S-P [N]	Fr2 C [N]
					Size	Pole		
32,3	2017	1,7	30,05	B143	160M	6	33229	33229
30,5	2113	2,7	47,53	B153	132MA/132M	4	60787	60787
30,0	2150	1,7	48,35	B143	132MA/132M	4	33782	33782
29,4	2216	1,5	33,01	B143	160M	6	33845	33845
29,1	2214	1,0	49,80	B123	132MA/132M	4	30000	9608
28,8	2257	2,6	33,63	B153	160M	6	61770	61770
28,7	2248	3,0	50,56	B153	132MA/132M	4	61906	61906
27,7	2350	2,5	35,02	B153	160M	6	62506	62506
27,3	2363	1,8	53,16	B143	132MA/132M	4	34392	34392
26,7	2414	1,1	54,30	B123	132MA/132M	4	30000	9708
26,5	2461	1,4	36,67	B143	160M	6	34507	34507
26,5	2429	1,8	54,63	B143	132MA/132M	4	34562	34562
26,5	2429	2,8	54,64	B153	132MA/132M	4	63331	63331
25,3	2546	2,7	57,27	B153	132MA/132M	4	64206	64206
25,0	2605	2,2	38,81	B153	160M	6	64407	64407
24,6	2624	1,6	59,02	B143	132MA/132M	4	35033	35033
24,4	2639	1,0	59,36	B123	132MA/132M	4	30000	9796
24,1	2704	1,3	40,29	B143	160M	6	35068	35068
23,8	2708	2,5	60,92	B153	132MA/132M	4	65000	65000
23,2	2782	1,0	62,59	B123	132MA/132M	4	30000	9842
22,9	2839	2,0	42,30	B153	160M	6	65000	65000
22,8	2822	2,4	63,47	B153	132MA/132M	4	65000	65000
22,3	2884	1,5	64,88	B143	132MA/132M	4	35580	35580
22,0	2964	1,2	44,16	B143	160M	6	35582	35582
20,6	3131	1,4	70,43	B143	132MA/132M	4	36022	36022
20,4	3190	1,8	47,53	B153	160M	6	65000	65000
20,4	3163	2,2	71,15	B153	132MA/132M	4	65000	65000
20,1	3245	1,1	48,35	B143	160M	6	36052	36052
19,2	3394	2,0	50,56	B153	160M	6	65000	65000
19,0	3423	3,2	51,00	B163	160M	6	80000	65000
18,8	3428	1,2	77,12	B143	132MA/132M	4	36472	36472
18,8	3433	2,0	77,22	B153	132MA/132M	4	65000	65000
18,2	3568	1,2	53,16	B143	160M	6	36497	36497
18,1	3600	3,1	53,63	B163	160M	6	80000	65000
17,8	3667	1,2	54,63	B143	160M	6	36615	36615
17,8	3667	1,9	54,64	B153	160M	6	65000	65000
17,3	3729	1,8	83,89	B153	132MA/132M	4	65000	65000
17,0	3803	1,1	85,54	B143	132MA/132M	4	36927	36927
16,9	3844	1,8	57,27	B153	160M	6	65000	65000
16,5	3897	1,8	87,65	B153	132MA/132M	4	65000	65000
16,5	3958	2,8	58,97	B163	160M	6	80000	65000
16,4	3961	1,1	59,02	B143	160M	6	36924	36924

6.1 B/BA GEARED MOTORS (50Hz)

7,50 kW

n2 [rpm]	M2 [Nm]	fs	i	Gear reducer	Motor Size	Pole	Fr2 D-S-P [N]	Fr2 C [N]
15,9	4089	1,7	60,92	B153	160M	6	65000	65000
15,6	4137	1,7	93,05	B153	132MA/132M	4	65000	65000
15,4	4185	1,0	94,13	B143	132MA/132M	4	37282	37282
15,3	4260	1,6	63,47	B153	160M	6	65000	65000
14,1	4584	1,5	103,12	B153	132MA/132M	4	65000	65000
13,9	4683	2,4	69,78	B163	160M	6	80000	65000
13,6	4775	1,4	71,15	B153	160M	6	65000	65000
12,6	5183	1,3	77,22	B153	160M	6	65000	65000
12,6	5149	2,2	76,72	B163	160M	6	80000	65000
11,7	5507	1,2	123,88	B153	132MA/132M	4	65000	65000
11,6	5631	1,2	83,89	B153	160M	6	65000	65000
11,1	5883	1,2	87,65	B153	160M	6	65000	65000
11,1	5875	1,9	87,54	B163	160M	6	80000	65000
10,8	5969	1,1	134,27	B153	132MA/132M	4	65000	65000
10,4	6245	1,1	93,05	B153	160M	6	65000	65000
10,1	6460	1,7	96,25	B163	160M	6	80000	65000
9,7	6636	1,0	149,26	B153	132MA/132M	4	65000	65000
9,3	6976	1,6	103,93	B163	160M	6	80000	65000
8,5	7670	1,4	114,27	B163	160M	6	80000	65000
7,7	8476	1,3	126,29	B163	160M	6	80000	65000
7,0	9320	1,2	138,85	B163	160M	6	80000	65000
6,3	10392	1,1	154,83	B163	160M	6	80000	65000

9,20 kW

n2 [rpm]	M2 [Nm]	fs	i	Gear reducer	Motor Size	Pole	Fr2 D-S-P [N]	Fr2 C [N]
182,0	434	1,9	7,97	B123	132MB	4	21927	6265
150,7	525	1,8	9,62	B123	132MB	4	23049	6586
140,3	564	2,2	10,33	B123	132MB	4	23480	6708
116,2	681	1,9	12,48	B123	132MB	4	24616	7033
104,7	755	1,9	13,84	B123	132MB	4	25241	7212
100,1	790	2,4	14,49	B143	132MB	4	24782	24782
94,3	839	1,8	15,38	B123	132MB	4	25871	7392
85,1	929	2,5	17,04	B143	132MB	4	25842	25842
84,0	942	1,1	17,27	B103	132MB	4	19056	5445
78,1	1013	1,6	18,58	B123	132MB	4	26980	7709
77,7	1017	2,6	18,66	B143	132MB	4	26435	26435
70,4	1124	1,6	20,61	B123	132MB	4	27573	7878
69,1	1145	2,3	21,00	B143	132MB	4	27208	27208
63,7	1242	1,6	22,78	B123	132MB	4	28129	8037
63,7	1242	2,6	22,77	B143	132MB	4	27737	27737
56,6	1398	2,1	25,63	B143	132MB	4	28500	28500

6.1 B/BA GEARED MOTORS (50Hz)

9,20 kW

n2 [rpm]	M2 [Nm]	fs	i	Gear reducer	Motor Size	Pole	Fr2 D-S-P [N]	Fr2 C [N]
56,0	1412	1,4	25,89	B123	132MB	4	28809	8231
52,8	1497	2,2	27,44	B143	132MB	4	28937	28937
52,7	1500	1,3	27,51	B123	132MB	4	29117	8319
48,3	1639	2,1	30,05	B143	132MB	4	29508	29508
47,1	1679	1,2	30,79	B123	132MB	4	29660	8474
46,4	1705	1,2	31,26	B123	132MB	4	29729	8494
43,9	1800	1,9	33,01	B143	132MB	4	30087	30087
41,8	1891	1,1	34,68	B123	132MB	4	30000	8623
39,5	2000	1,7	36,67	B143	132MB	4	30716	30716
36,0	2197	1,6	40,29	B143	132MB	4	31257	31257
34,3	2307	2,5	42,30	B153	132MB	4	58089	58089
32,8	2408	1,4	44,16	B143	132MB	4	31759	31759
30,5	2592	2,2	47,53	B153	132MB	4	60085	60085
30,0	2637	1,4	48,35	B143	132MB	4	32228	32228
28,7	2757	2,5	50,56	B153	132MB	4	61158	61158
27,3	2899	1,5	53,16	B143	132MB	4	32683	32683
26,5	2979	1,4	54,63	B143	132MB	4	32806	32806
26,5	2980	2,3	54,64	B153	132MB	4	62523	62523
25,3	3123	2,2	57,27	B153	132MB	4	63359	63359
24,6	3218	1,3	59,02	B143	132MB	4	33136	33136
23,8	3322	2,1	60,92	B153	132MB	4	64467	64467
22,8	3461	2,0	63,47	B153	132MB	4	65000	65000
22,3	3538	1,2	64,88	B143	132MB	4	33494	33494
20,6	3841	1,1	70,43	B143	132MB	4	33758	33758
20,4	3880	1,8	71,15	B153	132MB	4	65000	65000
18,8	4205	1,0	77,12	B143	132MB	4	33993	33993
18,8	4211	1,6	77,22	B153	132MB	4	65000	65000
17,3	4575	1,5	83,89	B153	132MB	4	65000	65000
16,5	4780	1,4	87,65	B153	132MB	4	65000	65000
15,6	5074	1,3	93,05	B153	132MB	4	65000	65000
14,1	5623	1,2	103,12	B153	132MB	4	65000	65000
11,7	6755	1,0	123,88	B153	132MB	4	65000	65000

11,00 kW

n2 [rpm]	M2 [Nm]	fs	i	Gear reducer	Motor Size	Pole	Fr2 D-S-P [N]	Fr2 C [N]
180,8	523	1,6	7,97	B123	132MC/160MA/160S	4	21575	6164
149,7	632	1,5	9,62	B123	132MC/160MA/160S	4	22616	6462
139,3	678	1,8	10,33	B123	132MC/160MA/160S	4	23011	6575
121,8	784	1,4	7,97	B123	160L	6	23714	6775
121,3	779	2,3	11,87	B143	132MC/160S	4	23137	23137
115,4	819	1,6	12,48	B123	132MC/160MA/160S	4	24042	6869

11,00 kW

n2 [rpm]	M2 [Nm]	fs	i	Gear reducer	Motor		Fr2 D-S-P [N]	Fr2 C [N]
					Size	Pole		
104,0	909	1,6	13,84	B123	132MC/160MA/160S	4	24599	7028
100,8	947	1,4	9,62	B123	160L	6	24720	7063
99,4	951	2,0	14,49	B143	132MC/160MA/160S	4	24331	24331
93,9	1017	1,4	10,33	B123	160L	6	25092	7169
93,6	1010	1,5	15,38	B123	132MC/160MA/160S	4	25153	7186
89,5	1067	2,0	10,84	B143	160L	6	24927	24927
84,5	1119	2,1	17,04	B143	132MC/160MA/160S	4	25303	25303
81,7	1168	1,9	11,87	B143	160L	6	25464	25464
77,7	1229	1,2	12,48	B123	160L	6	26034	7438
77,5	1220	1,3	18,58	B123	132MC/160MA/160S	4	26102	7458
77,2	1225	2,1	18,66	B143	132MC/160MA/160S	4	25841	25841
76,7	1245	2,6	12,64	B153	160L	6	45297	45297
70,1	1363	1,1	13,84	B123	160L	6	26520	7577
69,9	1353	1,3	20,61	B123	132MC/160MA/160S	4	26594	7598
69,2	1379	2,6	14,01	B153	160L	6	46724	46724
68,6	1379	1,9	21,00	B143	132MC/160MA/160S	4	26533	26533
67,0	1426	1,6	14,49	B143	160L	6	26627	26627
63,2	1496	1,4	22,78	B123	132MC/160MA/160S	4	27042	7726
63,2	1495	2,1	22,77	B143	132MC/160MA/160S	4	27002	27002
63,1	1514	1,0	15,38	B123	160L	6	26984	7710
63,0	1516	2,4	15,40	B153	160L	6	48069	48069
56,9	1678	1,4	17,04	B143	160L	6	27541	27541
56,2	1683	1,8	25,63	B143	132MC/160MA/160S	4	27666	27666
55,6	1700	1,2	25,89	B123	132MC/160MA/160S	4	27566	7876
52,5	1802	1,8	27,44	B143	132MC/160MA/160S	4	28041	28041
52,3	1806	1,1	27,51	B123	132MC/160MA/160S	4	27793	7941
52,3	1827	2,4	18,56	B153	160L	6	50804	50804
52,0	1837	1,4	18,66	B143	160L	6	28032	28032
47,9	1974	1,0	30,79	B123	160MA	4	28096	8027
47,9	1973	1,7	30,05	B143	132MC/160MA/160S	4	28521	28521
47,2	2004	1,0	31,26	B123	160MA	4	28143	8041
47,2	2024	2,3	20,56	B153	160L	6	52359	52359
46,2	2067	1,4	21,00	B143	160L	6	28645	28645
43,6	2167	1,6	33,01	B143	132MC/160MA/160S	4	28998	28998
42,8	2208	2,6	33,63	B153	132MC/160MA/160S	4	53886	53886
42,6	2242	1,4	22,77	B143	160L	6	29044	29044
41,1	2299	2,5	35,02	B153	160MA/160S	4	54519	54519
40,7	2349	2,1	23,86	B153	160L	6	54664	54664
39,3	2408	1,4	36,67	B143	132MC/160MA/160S	4	29500	29500
38,5	2480	2,0	25,19	B153	160L	6	55521	55521
37,8	2523	1,3	25,63	B143	160L	6	29586	29586
37,1	2548	2,3	38,81	B153	160MA/160S	4	56150	56150

11,00 kW

n2 [rpm]	M2 [Nm]	fs	i	Gear reducer	Motor		Fr2 D-S-P [N]	Fr2 C [N]
					Size	Pole		
35,7	2645	1,3	40,29	B143	132MC/160MA/160S	4	29915	29915
35,3	2702	1,2	27,44	B143	160L	6	29876	29876
34,4	2779	2,1	28,23	B153	160L	6	57351	57351
34,0	2777	2,1	42,30	B153	132MC/160MA/160S	4	57540	57540
33,7	2835	2,6	28,80	B163	160L	6	80000	65000
32,6	2899	1,2	44,16	B143	132MC/160MA/160S	4	30283	30283
32,3	2958	1,1	30,05	B143	160L	6	30227	30227
32,0	2988	1,9	30,35	B153	160L	6	58529	58529
31,4	3044	2,7	30,92	B163	160L	6	80000	65000
30,3	3121	1,9	47,53	B153	132MC/160MA/160S	4	59455	59455
29,8	3175	1,1	48,35	B143	132MC/160MA/160S	4	30605	30605
29,4	3250	1,0	33,01	B143	160L	6	30547	30547
28,8	3311	1,7	33,63	B153	160L	6	60224	60224
28,5	3320	2,1	50,56	B153	132MC/160MA/160S	4	60483	60483
28,3	3372	2,6	34,25	B163	160L	6	80000	65000
28,2	3348	3,3	51,00	B163	160MA/160S	4	80000	65000
27,7	3447	1,7	35,02	B153	160L	6	60897	60897
27,1	3490	1,2	53,16	B143	132MC/160MA/160S	4	30893	30893
26,9	3521	3,2	53,63	B163	160MA/160S	4	80000	65000
26,4	3587	1,2	54,63	B143	132MC/160MA/160S	4	30965	30965
26,4	3587	1,9	54,64	B153	132MC/160MA/160S	4	61784	61784
25,8	3708	2,4	37,66	B163	160L	6	80000	65000
25,1	3760	1,8	57,27	B153	132MC/160MA/160S	4	62580	62580
25,0	3820	1,5	38,81	B153	160L	6	62624	62624
24,4	3875	1,1	59,02	B143	132MC/160MA/160S	4	31141	31141
24,4	3871	2,9	58,97	B163	160MA/160S	4	80000	65000
23,9	4002	2,3	40,65	B163	160L	6	80000	65000
23,6	4000	1,7	60,92	B153	132MC/160MA/160S	4	63631	63631
22,9	4164	1,4	42,30	B153	160L	6	64086	64086
22,7	4167	1,6	63,47	B153	132MC/160MA/160S	4	64332	64332
22,2	4260	1,0	64,88	B143	132MC/160MA/160S	4	31294	31294
21,5	4439	2,0	45,09	B163	160L	6	80000	65000
20,6	4581	2,4	69,78	B163	160MA/160S	4	80000	65000
20,4	4679	1,2	47,53	B153	160L	6	65000	65000
20,2	4671	1,5	71,15	B153	132MC/160MA/160S	4	65000	65000
19,2	4978	1,4	50,56	B153	160L	6	65000	65000
19,0	5021	2,2	51,00	B163	160L	6	80000	65000
18,8	5037	2,2	76,72	B163	160MA/160S	4	80000	65000
18,6	5070	1,3	77,22	B153	132MC/160MA/160S	4	65000	65000
18,1	5279	2,1	53,63	B163	160L	6	80000	65000
17,8	5379	1,3	54,64	B153	160L	6	65000	65000
17,2	5508	1,2	83,89	B153	132MC/160MA/160S	4	65000	65000

11,00 kW

n2 [rpm]	M2 [Nm]	fs	i	Gear reducer	Motor Size	Pole	Fr2 D-S-P [N]	Fr2 C [N]
16,9	5638	1,2	57,27	B153	160L	6	65000	65000
16,5	5805	1,9	58,97	B163	160L	6	80000	65000
16,5	5747	1,9	87,54	B163	160MA/160S	4	80000	65000
16,4	5755	1,2	87,65	B153	132MC/160MA/160S	4	65000	65000
15,9	5997	1,1	60,92	B153	160L	6	65000	65000
15,5	6109	1,1	93,05	B153	132MC/160MA/160S	4	65000	65000
15,3	6248	1,1	63,47	B153	160L	6	65000	65000
15,0	6319	1,8	96,25	B163	160MA/160S	4	80000	65000
14,0	6770	1,0	103,12	B153	132MC/160MA/160S	4	65000	65000
13,9	6869	1,6	69,78	B163	160L	6	80000	65000
13,9	6824	1,6	103,93	B163	160MA/160S	4	80000	65000
12,6	7552	1,5	76,72	B163	160L	6	80000	65000
12,6	7503	1,5	114,27	B163	160MA/160S	4	80000	65000
11,4	8292	1,3	126,29	B163	160MA/160S	4	80000	65000
11,1	8617	1,3	87,54	B163	160L	6	80000	65000
10,4	9117	1,2	138,85	B163	160MA/160S	4	80000	65000
10,1	9475	1,2	96,25	B163	160L	6	80000	65000
9,3	10231	1,1	103,93	B163	160L	6	80000	65000
9,3	10166	1,1	154,83	B163	160MA/160S	4	80000	65000

15,00 kW

n2 [rpm]	M2 [Nm]	fs	i	Gear reducer	Motor Size	Pole	Fr2 D-S-P [N]	Fr2 C [N]
185,2	696	1,2	7,97	B123	160LA	4	20589	5883
153,3	841	1,1	9,62	B123	160LA	4	21453	6129
142,7	903	1,3	10,33	B123	160LA	4	21771	6220
136,1	947	1,8	10,84	B143	160LA	4	21649	21649
124,3	1037	1,7	11,87	B143	160LA	4	22112	22112
123,0	1058	1,0	7,97	B123	180L ⁽²⁾	6	22361	6389
118,2	1091	1,2	12,48	B123	160LA	4	22574	6450
106,5	1210	1,1	13,84	B123	160LA	4	22988	6568
101,9	1278	1,0	9,62	B123	180L ⁽²⁾	6	23100	6600
101,8	1266	1,5	14,49	B143	160LA	4	23110	23110
95,9	1345	1,1	15,38	B123	160LA	4	23379	6680
95,8	1346	2,7	15,40	B153	160LA	4	41822	41822
94,8	1373	1,1	10,33	B123	180L ⁽²⁾	6	23356	6673
93,4	1394	2,3	10,49	B153	180L ⁽²⁾	6	42116	42116
90,4	1440	1,5	10,84	B143	180L ⁽²⁾	6	23641	23641
86,6	1489	1,6	17,04	B143	160LA	4	23893	23893
82,6	1577	1,4	11,87	B143	180L ⁽²⁾	6	24062	24062
79,5	1622	2,5	18,56	B153	160LA	4	44196	44196
79,1	1631	1,6	18,66	B143	160LA	4	24312	24312

⁽²⁾ With TBS brake motor, please contact our Technical Sales Support

15,00 kW

n2 [rpm]	M2 [Nm]	fs	i	Gear reducer	Motor Size	Pole	Fr2 D-S-P [N]	Fr2 C [N]
77,5	1680	1,9	12,64	B153	180L ⁽²⁾	6	44499	44499
71,7	1797	2,4	20,56	B153	160LA	4	45545	45545
71,6	1801	1,0	20,61	B123	160LA	4	24275	6936
70,2	1835	1,4	21,00	B143	160LA	4	24832	24832
69,9	1862	1,9	14,01	B153	180L ⁽²⁾	6	45852	45852
67,7	1925	1,2	14,49	B143	180L ⁽²⁾	6	24931	24931
64,8	1990	1,6	22,77	B143	160LA	4	25171	25171
64,7	1991	1,0	22,78	B123	160LA	4	24497	6999
63,6	2046	1,8	15,40	B153	180L ⁽²⁾	6	47121	47121
61,8	2085	2,1	23,86	B153	160LA	4	47544	47544
58,6	2202	2,2	25,19	B153	160LA	4	48287	48287
57,6	2240	1,3	25,63	B143	160LA	4	25627	25627
57,5	2264	1,0	17,04	B143	180L ⁽²⁾	6	25559	25559
53,7	2399	1,4	27,44	B143	160LA	4	25870	25870
52,8	2465	1,8	18,56	B153	180L ⁽²⁾	6	49686	49686
52,5	2479	1,0	18,66	B143	180L ⁽²⁾	6	25869	25869
52,2	2468	2,3	28,23	B153	160LA	4	49873	49873
49,1	2626	1,3	30,05	B143	160LA	4	26162	26162
48,6	2653	2,2	30,35	B153	160LA	4	50894	50894
47,7	2732	1,7	20,56	B153	180L ⁽²⁾	6	51133	51133
46,7	2790	1,0	21,00	B143	180L ⁽²⁾	6	26220	26220
44,7	2885	1,2	33,01	B143	160LA	4	26424	26424
44,7	2916	2,6	21,94	B163	180L ⁽²⁾	6	80000	65000
43,9	2940	2,0	33,63	B153	160LA	4	52362	52362
43,1	2994	2,9	34,25	B163	160LA	4	80000	65000
43,0	3026	1,1	22,77	B143	180L ⁽²⁾	6	26421	26421
42,1	3061	1,9	35,02	B153	160LA	4	52944	52944
41,1	3170	1,5	23,86	B153	180L ⁽²⁾	6	53262	53262
40,5	3212	2,4	24,17	B163	180L ⁽²⁾	6	80000	65000
40,2	3205	1,1	36,67	B143	160LA	4	26662	26662
39,2	3292	2,7	37,66	B163	160LA	4	80000	65000
38,9	3347	1,5	25,19	B153	180L ⁽²⁾	6	54049	54049
38,0	3392	1,7	38,81	B153	160LA	4	54439	54439
36,9	3531	2,3	26,58	B163	180L ⁽²⁾	6	80000	65000
36,3	3553	2,6	40,65	B163	160LA	4	80000	65000
34,9	3697	1,6	42,30	B153	160LA	4	55704	55704
34,7	3751	1,5	28,23	B153	180L ⁽²⁾	6	55717	55717
34,0	3827	1,9	28,80	B163	180L ⁽²⁾	6	80000	65000
32,7	3941	2,2	45,09	B163	160LA	4	80000	65000
32,3	4032	1,4	30,35	B153	180L ⁽²⁾	6	56783	56783
31,7	4109	2,0	30,92	B163	180L ⁽²⁾	6	80000	65000
31,0	4155	1,4	47,53	B153	160LA	4	57433	57433

⁽²⁾ With TBS brake motor, please contact our Technical Sales Support

15,00 kW

n2 [rpm]	M2 [Nm]	fs	i	Gear reducer	Motor Size	Pole	Fr2 D-S-P [N]	Fr2 C [N]
29,2	4419	1,5	50,56	B153	160LA	4	58353	58353
29,1	4469	1,3	33,63	B153	180L ⁽²⁾	6	58306	58306
28,9	4458	2,5	51,00	B163	160LA	4	80000	65000
28,6	4551	1,9	34,25	B163	180L ⁽²⁾	6	80000	65000
28,0	4653	1,2	35,02	B153	180L ⁽²⁾	6	58905	58905
27,5	4688	2,4	53,63	B163	160LA	4	80000	65000
27,0	4776	1,4	54,64	B153	160LA	4	59512	59512
26,0	5004	1,8	37,66	B163	180L ⁽²⁾	6	80000	65000
25,8	5006	1,4	57,27	B153	160LA	4	60215	60215
25,3	5156	1,1	38,81	B153	180L ⁽²⁾	6	60434	60434
25,0	5154	2,2	58,97	B163	160LA	4	80000	65000
24,2	5325	1,3	60,92	B153	160LA	4	61139	61139
24,1	5402	1,7	40,65	B163	180L ⁽²⁾	6	80000	65000
23,2	5548	1,2	63,47	B153	160LA	4	61750	61750
23,2	5620	1,0	42,30	B153	180L ⁽²⁾	6	61713	61713
21,7	5991	1,4	45,09	B163	180L ⁽²⁾	6	80000	65000
21,1	6099	1,8	69,78	B163	160LA	4	80000	65000
20,7	6219	1,1	71,15	B153	160LA	4	63449	63449
19,4	6718	1,0	50,56	B153	180L ⁽²⁾	6	64347	64347
19,2	6776	1,6	51,00	B163	180L ⁽²⁾	6	80000	65000
19,2	6706	1,7	76,72	B163	160LA	4	80000	65000
19,1	6750	1,0	77,22	B153	160LA	4	64660	64660
18,3	7126	1,6	53,63	B163	180L ⁽²⁾	6	80000	65000
16,9	7651	1,5	87,54	B163	160LA	4	80000	65000
16,6	7835	1,4	58,97	B163	180L ⁽²⁾	6	80000	65000
15,3	8413	1,3	96,25	B163	160LA	4	80000	65000
14,2	9084	1,2	103,93	B163	160LA	4	80000	65000
14,0	9271	1,2	69,78	B163	180L ⁽²⁾	6	80000	65000
12,9	9988	1,1	114,27	B163	160LA	4	80000	65000
12,8	10194	1,1	76,72	B163	180L ⁽²⁾	6	80000	65000
11,7	11038	1,0	126,29	B163	160LA	4	80000	65000

18,50 kW

n2 [rpm]	M2 [Nm]	fs	i	Gear reducer	Motor Size	Pole	Fr2 D-S-P [N]	Fr2 C [N]
142,2	1118	1,1	10,33	B123	180M ⁽²⁾	4	20814	5947
140,1	1135	2,2	10,49	B153	180M ⁽²⁾	4	36966	36966
135,6	1172	1,4	10,84	B143	180M ⁽²⁾	4	20959	20959
123,9	1284	1,4	11,87	B143	180M ⁽²⁾	4	21354	21354
116,3	1367	2,0	12,64	B153	180M ⁽²⁾	4	39075	39075
104,9	1515	1,9	14,01	B153	180M ⁽²⁾	4	40275	40275
101,5	1567	1,2	14,49	B143	180M ⁽²⁾	4	22181	22181

⁽²⁾ With TBS brake motor, please contact our Technical Sales Support

18,50 kW

n2 [rpm]	M2 [Nm]	fs	i	Gear reducer	Motor Size	Pole	Fr2 D-S-P [N]	Fr2 C [N]
95,5	1666	2,2	15,40	B153	180M ⁽²⁾	4	41402	41402
93,4	1719	1,9	10,49	B153	200LA ⁽²⁾	6	41639	41639
90,4	1776	1,2	10,84	B143	200LA ⁽²⁾	6	22569	22569
86,3	1843	1,3	17,04	B143	180M ⁽²⁾	4	22796	22796
82,6	1945	1,2	11,87	B143	200LA ⁽²⁾	6	22889	22889
79,2	2007	2,0	18,56	B153	180M ⁽²⁾	4	43683	43683
78,8	2018	1,3	18,66	B143	180M ⁽²⁾	4	23109	23109
77,5	2072	1,6	12,64	B153	200LA ⁽²⁾	6	43924	43924
71,5	2224	1,9	20,56	B153	180M ⁽²⁾	4	44973	44973
70,0	2271	1,1	21,00	B143	180M ⁽²⁾	4	23476	23476
69,9	2296	1,6	14,01	B153	200LA ⁽²⁾	6	45215	45215
64,6	2463	1,3	22,77	B143	180M ⁽²⁾	4	23698	23698
63,6	2524	1,4	15,40	B153	200LA ⁽²⁾	6	46421	46421
61,6	2581	1,7	23,86	B153	180M ⁽²⁾	4	46874	46874
59,8	2685	2,7	16,39	B163	200LA ⁽²⁾	6	75172	65000
58,4	2724	1,8	25,19	B153	180M ⁽²⁾	4	47578	47578
57,4	2772	1,0	25,63	B143	180M ⁽²⁾	4	23967	23967
55,3	2875	2,7	26,58	B163	180M ⁽²⁾	4	76928	65000
54,4	2952	2,5	18,02	B163	200LA ⁽²⁾	6	77244	65000
53,6	2968	1,1	27,44	B143	180M ⁽²⁾	4	24090	24090
52,8	3041	1,4	18,56	B153	200LA ⁽²⁾	6	48842	48842
52,1	3054	1,9	28,23	B153	180M ⁽²⁾	4	49073	49073
51,0	3115	2,4	28,80	B163	180M ⁽²⁾	4	78709	65000
49,1	3270	2,4	19,96	B163	200LA ⁽²⁾	6	79518	65000
48,9	3250	1,0	30,05	B143	180M ⁽²⁾	4	24210	24210
48,4	3283	1,8	30,35	B153	180M ⁽²⁾	4	50031	50031
47,7	3370	1,4	20,56	B153	200LA ⁽²⁾	6	50198	50198
47,5	3345	2,5	30,92	B163	180M ⁽²⁾	4	80000	65000
44,7	3596	2,1	21,94	B163	200LA ⁽²⁾	6	80000	65000
43,7	3638	1,6	33,63	B153	180M ⁽²⁾	4	51401	51401
42,9	3705	2,3	34,25	B163	180M ⁽²⁾	4	80000	65000
42,0	3788	1,5	35,02	B153	180M ⁽²⁾	4	51942	51942
41,1	3910	1,2	23,86	B153	200LA ⁽²⁾	6	52177	52177
40,5	3961	1,9	24,17	B163	200LA ⁽²⁾	6	80000	65000
39,0	4074	2,2	37,66	B163	180M ⁽²⁾	4	80000	65000
38,9	4128	1,2	25,19	B153	200LA ⁽²⁾	6	52903	52903
37,9	4198	1,4	38,81	B153	180M ⁽²⁾	4	53324	53324
36,9	4355	1,8	26,58	B163	200LA ⁽²⁾	6	80000	65000
36,2	4397	2,1	40,65	B163	180M ⁽²⁾	4	80000	65000
34,8	4575	1,3	42,30	B153	180M ⁽²⁾	4	54484	54484
34,7	4626	1,2	28,23	B153	200LA ⁽²⁾	6	54433	54433
34,0	4720	1,6	28,80	B163	200LA ⁽²⁾	6	80000	65000

(2) With TBS brake motor, please contact our Technical Sales Support

18,50 kW

n2 [rpm]	M2 [Nm]	fs	i	Gear reducer	Motor Size	Pole	Fr2 D-S-P [N]	Fr2 C [N]
32,6	4877	1,8	45,09	B163	180M ⁽²⁾	4	80000	65000
32,3	4973	1,2	30,35	B153	200LA ⁽²⁾	6	55403	55403
31,7	5068	1,6	30,92	B163	200LA ⁽²⁾	6	80000	65000
30,9	5142	1,1	47,53	B153	180M ⁽²⁾	4	56057	56057
29,1	5512	1,0	33,63	B153	200LA ⁽²⁾	6	56776	56776
29,1	5469	1,2	50,56	B153	180M ⁽²⁾	4	56886	56886
28,8	5517	2,0	51,00	B163	180M ⁽²⁾	4	80000	65000
28,6	5613	1,5	34,25	B163	200LA ⁽²⁾	6	80000	65000
28,0	5738	1,0	35,02	B153	200LA ⁽²⁾	6	57313	57313
27,4	5801	1,9	53,63	B163	180M ⁽²⁾	4	80000	65000
26,9	5910	1,2	54,64	B153	180M ⁽²⁾	4	57922	57922
26,0	6172	1,4	37,66	B163	200LA ⁽²⁾	6	80000	65000
25,7	6195	1,1	57,27	B153	180M ⁽²⁾	4	58546	58546
24,9	6378	1,7	58,97	B163	180M ⁽²⁾	4	80000	65000
24,1	6590	1,0	60,92	B153	180M ⁽²⁾	4	59360	59360
24,1	6662	1,4	40,65	B163	200LA ⁽²⁾	6	80000	65000
21,7	7389	1,2	45,09	B163	200LA ⁽²⁾	6	80000	65000
21,1	7547	1,5	69,78	B163	180M ⁽²⁾	4	80000	65000
19,2	8358	1,3	51,00	B163	200LA ⁽²⁾	6	80000	65000
19,2	8298	1,3	76,72	B163	180M ⁽²⁾	4	80000	65000
18,3	8788	1,3	53,63	B163	200LA ⁽²⁾	6	80000	65000
16,8	9469	1,2	87,54	B163	180M ⁽²⁾	4	80000	65000
16,6	9663	1,1	58,97	B163	200LA ⁽²⁾	6	80000	65000
15,3	10411	1,1	96,25	B163	180M ⁽²⁾	4	80000	65000

22,00 kW

n2 [rpm]	M2 [Nm]	fs	i	Gear reducer	Motor Size	Pole	Fr2 D-S-P [N]	Fr2 C [N]
140,1	1350	1,8	10,49	B153	180L ⁽²⁾	4	36651	36651
135,6	1394	1,2	10,84	B143	180L ⁽²⁾	4	20251	20251
123,9	1527	1,1	11,87	B143	180L ⁽²⁾	4	20579	20579
116,3	1626	1,7	12,64	B153	180L ⁽²⁾	4	38696	38696
104,9	1802	1,6	14,01	B153	180L ⁽²⁾	4	39855	39855
101,5	1863	1,0	14,49	B143	180L ⁽²⁾	4	21235	21235
95,5	1981	1,8	15,40	B153	180L ⁽²⁾	4	40939	40939
93,4	2045	1,6	10,49	B153	200LB ⁽²⁾	6	41162	41162
90,4	2112	1,0	10,84	B143	200LB ⁽²⁾	6	21497	21497
86,3	2192	1,1	17,04	B143	180L ⁽²⁾	4	21684	21684
82,6	2313	2,4	11,87	B163	200LB ⁽²⁾	6	67760	65000
79,2	2387	1,7	18,56	B153	180L ⁽²⁾	4	43126	43126
78,8	2400	1,1	18,66	B143	180L ⁽²⁾	4	21891	21891
77,5	2464	1,3	12,64	B153	200LB ⁽²⁾	6	43349	43349

⁽²⁾ With TBS brake motor, please contact our Technical Sales Support

22,00 kW

n2 [rpm]	M2 [Nm]	fs	i	Gear reducer	Motor Size	Pole	Fr2 D-S-P [N]	Fr2 C [N]
76,5	2496	2,5	12,81	B163	200LB ⁽²⁾	6	69268	65000
71,5	2645	1,6	20,56	B153	180L ⁽²⁾	4	44355	44355
69,9	2730	1,3	14,01	B153	200LB ⁽²⁾	6	44578	44578
69,6	2745	2,4	14,08	B163	200LB ⁽²⁾	6	71175	65000
67,0	2823	2,1	21,94	B163	180L ⁽²⁾	4	71998	65000
64,6	2929	1,1	22,77	B143	180L ⁽²⁾	4	22211	22211
63,6	3001	1,2	15,40	B153	200LB ⁽²⁾	6	45720	45720
63,1	3025	2,4	15,52	B163	200LB ⁽²⁾	6	73163	65000
61,6	3069	1,5	23,86	B153	180L ⁽²⁾	4	46158	46158
60,8	3109	2,4	24,17	B163	180L ⁽²⁾	4	73993	65000
59,8	3193	2,2	16,39	B163	200LB ⁽²⁾	6	74284	65000
58,4	3240	1,5	25,19	B153	180L ⁽²⁾	4	46821	46821
55,3	3419	2,2	26,58	B163	180L ⁽²⁾	4	75978	65000
54,4	3511	2,1	18,02	B163	200LB ⁽²⁾	6	76268	65000
52,8	3616	1,2	18,56	B153	200LB ⁽²⁾	6	47998	47998
52,1	3631	1,6	28,23	B153	180L ⁽²⁾	4	48226	48226
51,0	3705	2,0	28,80	B163	180L ⁽²⁾	4	77679	65000
49,1	3889	2,0	19,96	B163	200LB ⁽²⁾	6	78437	65000
48,4	3904	1,5	30,35	B153	180L ⁽²⁾	4	49120	49120
47,7	4007	1,2	20,56	B153	200LB ⁽²⁾	6	49263	49263
47,5	3978	2,1	30,92	B163	180L ⁽²⁾	4	79200	65000
44,7	4276	1,8	21,94	B163	200LB ⁽²⁾	6	80000	65000
43,7	4326	1,3	33,63	B153	180L ⁽²⁾	4	50392	50392
42,9	4406	2,0	34,25	B163	180L ⁽²⁾	4	80000	65000
42,0	4504	1,3	35,02	B153	180L ⁽²⁾	4	50891	50891
41,1	4649	1,0	23,86	B153	200LB ⁽²⁾	6	51092	51092
40,5	4711	1,6	24,17	B163	200LB ⁽²⁾	6	80000	65000
39,0	4845	1,8	37,66	B163	180L ⁽²⁾	4	80000	65000
38,9	4908	1,0	25,19	B153	200LB ⁽²⁾	6	51758	51758
37,9	4992	1,2	38,81	B153	180L ⁽²⁾	4	52159	52159
36,9	5179	1,5	26,58	B163	200LB ⁽²⁾	6	80000	65000
36,2	5229	1,8	40,65	B163	180L ⁽²⁾	4	80000	65000
34,8	5441	1,1	42,30	B153	180L ⁽²⁾	4	53215	53215
34,7	5502	1,1	28,23	B153	200LB ⁽²⁾	6	53149	53149
34,0	5612	1,3	28,80	B163	200LB ⁽²⁾	6	80000	65000
32,6	5800	1,5	45,09	B163	180L ⁽²⁾	4	80000	65000
31,7	6026	1,4	30,92	B163	200LB ⁽²⁾	6	80000	65000
29,1	6504	1,1	50,56	B153	180L ⁽²⁾	4	55368	55368
28,8	6560	1,7	51,00	B163	180L ⁽²⁾	4	80000	65000
28,6	6675	1,3	34,25	B163	200LB ⁽²⁾	6	80000	65000
27,4	6898	1,6	53,63	B163	180L ⁽²⁾	4	80000	65000
26,0	7339	1,2	37,66	B163	200LB ⁽²⁾	6	80000	65000

(2) With TBS brake motor, please contact our Technical Sales Support

22,00 kW

n2 [rpm]	M2 [Nm]	fs	i	Gear reducer	Motor Size	Motor Pole	Fr2 D-S-P [N]	Fr2 C [N]
24,9	7585	1,5	58,97	B163	180L ⁽²⁾	4	80000	65000
24,1	7922	1,2	40,65	B163	200LB ⁽²⁾	6	80000	65000
21,1	8975	1,2	69,78	B163	180L ⁽²⁾	4	80000	65000
19,2	9939	1,1	51,00	B163	200LB ⁽²⁾	6	80000	65000
19,2	9868	1,1	76,72	B163	180L ⁽²⁾	4	80000	65000
18,3	10451	1,1	53,63	B163	200LB ⁽²⁾	6	80000	65000

30,00 kW

n2 [rpm]	M2 [Nm]	fs	i	Gear reducer	Motor Size	Motor Pole	Fr2 D-S-P [N]	Fr2 C [N]
140,6	1834	1,3	10,49	B153	200L ⁽²⁾	4	35897	35897
124,3	2075	2,1	11,87	B163	200L ⁽²⁾	4	59114	59114
116,7	2210	1,2	12,64	B153	200L ⁽²⁾	4	37793	37793
115,2	2239	1,8	12,81	B163	200L ⁽²⁾	4	60424	60424
105,3	2449	1,2	14,01	B153	200L ⁽²⁾	4	38858	38858
104,7	2462	1,8	14,08	B163	200L ⁽²⁾	4	62080	62080
95,8	2692	1,3	15,40	B153	200L ⁽²⁾	4	39847	39847
95,0	2713	1,8	15,52	B163	200L ⁽²⁾	4	63806	63806
90,0	2864	2,0	16,39	B163	200L ⁽²⁾	4	64778	64778
81,9	3149	1,9	18,02	B163	200L ⁽²⁾	4	66499	65000
79,5	3244	1,3	18,56	B153	200L ⁽²⁾	4	41817	41817
73,9	3489	1,9	19,96	B163	200L ⁽²⁾	4	68378	65000
71,7	3595	1,2	20,56	B153	200L ⁽²⁾	4	42908	42908
67,2	3836	1,5	21,94	B163	200L ⁽²⁾	4	70141	65000
61,8	4171	1,1	23,86	B153	200L ⁽²⁾	4	44485	44485
61,0	4226	1,7	24,17	B163	200L ⁽²⁾	4	71953	65000
58,6	4403	1,1	25,19	B153	200L ⁽²⁾	4	45057	45057
55,5	4646	1,6	26,58	B163	200L ⁽²⁾	4	73741	65000
52,2	4935	1,2	28,23	B153	200L ⁽²⁾	4	46253	46253
51,2	5035	1,5	28,80	B163	200L ⁽²⁾	4	75261	65000
48,6	5305	1,1	30,35	B153	200L ⁽²⁾	4	47002	47002
47,7	5406	1,5	30,92	B163	200L ⁽²⁾	4	76609	65000
43,1	5988	1,4	34,25	B163	200L ⁽²⁾	4	78546	65000
39,2	6584	1,4	37,66	B163	200L ⁽²⁾	4	80000	65000
36,3	7107	1,3	40,65	B163	200L ⁽²⁾	4	80000	65000
32,7	7883	1,1	45,09	B163	200L ⁽²⁾	4	80000	65000
28,9	8915	1,2	51,00	B163	200L ⁽²⁾	4	80000	65000
27,5	9375	1,2	53,63	B163	200L ⁽²⁾	4	80000	65000
25,0	10308	1,1	58,97	B163	200L ⁽²⁾	4	80000	65000

⁽²⁾ With TBS brake motor, please contact our Technical Sales Support

37,00 kW

n2 [rpm]	M2 [Nm]	fs	i	Gear reducer	Motor Size	Pole	Fr2 D-S-P [N]	Fr2 C [N]
167,0	1904	1,3	8,89	B163	225S ⁽²⁾	4	53581	53581
141,5	2247	1,1	10,49	B153	225S ⁽²⁾	4	35205	35205
140,4	2265	1,3	10,58	B163	225S ⁽²⁾	4	56303	56303
125,1	2542	1,7	11,87	B163	225S ⁽²⁾	4	58158	58158
115,9	2743	1,5	12,81	B163	225S ⁽²⁾	4	59400	59400
105,4	3016	1,4	14,08	B163	225S ⁽²⁾	4	60964	60964
96,4	3298	1,1	15,40	B153	225S ⁽²⁾	4	38861	38861
95,7	3324	1,5	15,52	B163	225S ⁽²⁾	4	62586	62586
90,6	3509	1,6	16,39	B163	225S ⁽²⁾	4	63497	63497
82,4	3858	1,5	18,02	B163	225S ⁽²⁾	4	65101	65000
80,0	3974	1,0	18,56	B153	225S ⁽²⁾	4	40642	40642
74,4	4274	1,5	19,96	B163	225S ⁽²⁾	4	66841	65000
67,7	4699	1,2	21,94	B163	225S ⁽²⁾	4	68462	65000
61,4	5177	1,4	24,17	B163	225S ⁽²⁾	4	70115	65000
55,9	5692	1,3	26,58	B163	225S ⁽²⁾	4	71732	65000
51,6	6168	1,2	28,80	B163	225S ⁽²⁾	4	73094	65000
48,0	6622	1,3	30,92	B163	225S ⁽²⁾	4	74292	65000
43,4	7335	1,2	34,25	B163	225S ⁽²⁾	4	75993	65000
39,4	8065	1,1	37,66	B163	225S ⁽²⁾	4	77542	65000
36,5	8706	1,1	40,65	B163	225S ⁽²⁾	4	78763	65000
29,1	10922	1,0	51,00	B163	225S ⁽²⁾	4	80000	65000

45,00 kW

n2 [rpm]	M2 [Nm]	fs	i	Gear reducer	Motor Size	Pole	Fr2 D-S-P [N]	Fr2 C [N]
167,0	2316	1,1	8,89	B163	225M ⁽²⁾	4	52862	52862
140,4	2754	1,0	10,58	B163	225M ⁽²⁾	4	55447	55447
125,1	3091	1,4	11,87	B163	225M ⁽²⁾	4	57198	57198
115,9	3336	1,2	12,81	B163	225M ⁽²⁾	4	58364	58364
105,4	3668	1,2	14,08	B163	225M ⁽²⁾	4	59825	59825
95,7	4043	1,2	15,52	B163	225M ⁽²⁾	4	61331	61331
90,6	4268	1,3	16,39	B163	225M ⁽²⁾	4	62171	62171
82,4	4692	1,3	18,02	B163	225M ⁽²⁾	4	63643	63643
74,4	5198	1,3	19,96	B163	225M ⁽²⁾	4	65226	65000
67,7	5715	1,0	21,94	B163	225M ⁽²⁾	4	66687	65000
61,4	6296	1,2	24,17	B163	225M ⁽²⁾	4	68160	65000
55,9	6922	1,1	26,58	B163	225M ⁽²⁾	4	69582	65000
48,0	8054	1,0	30,92	B163	225M ⁽²⁾	4	71790	65000

⁽²⁾ With TBS brake motor, please contact our Technical Sales Support

6.1 B/BA GEARED MOTORS (50Hz)

55,00 kW

n2 [rpm]	M2 [Nm]	fs	i	Gear reducer	Size	Motor Pole	Fr2 D-S-P [N]	Fr2 C [N]
125,1	3778	1,1	11,87	B163	250M ⁽²⁾	4	55998	55998
95,7	4941	1,0	15,52	B163	250M ⁽²⁾	4	59761	59761
90,6	5216	1,1	16,39	B163	250M ⁽²⁾	4	60514	60514
82,4	5735	1,0	18,02	B163	250M ⁽²⁾	4	61821	61821
74,4	6353	1,0	19,96	B163	250M ⁽²⁾	4	63208	63208

⁽²⁾ With TBS brake motor, please contact our Technical Sales Support

IBA42

Mn ₂ [Nm]	i	Pn ₁ [kW]	n ₂ [rpm]	Fr1 [N]	Fr2 D-S-P [N]	Fr2 C [N]
77	7,62	1,95	229,8	373	-	1684
77	10,62	1,40	164,7	355	-	1882
77	12,95	1,15	135,2	406	-	2010
77	14,46	1,03	121,0	443	-	2085
102	16,47	1,19	106,2	579	-	2178
103	22,97	0,86	76,2	355	-	2433
102	28,00	0,70	62,5	406	-	2599
102	31,27	0,63	56,0	443	-	2697
103	33,78	0,59	51,8	458	-	2767
102	47,12	0,42	37,1	355	-	3092
102	57,43	0,34	30,5	406	-	3303
92	64,13	0,28	27,3	406	-	3426
95	78,17	0,23	22,4	406	-	3660

IBA52

Mn ₂ [Nm]	i	Pn ₁ [kW]	n ₂ [rpm]	Fr1 [N]	Fr2 D-S-P [N]	Fr2 C [N]
137	7,91	3,34	221,2	373	-	1828
137	9,46	2,79	185,0	414	-	1940
136	11,57	2,27	151,2	405	-	2075
137	14,63	1,81	119,7	392	-	2243
171	17,11	1,93	102,3	529	-	2363
171	20,46	1,61	85,5	414	-	2508
170	25,03	1,31	69,9	405	-	2683
172	31,63	1,05	55,3	392	-	2900
171	35,10	0,94	49,9	446	-	3003
172	41,97	0,79	41,7	414	-	3187
188	51,34	0,71	34,1	445	-	3409
172	64,87	0,51	27,0	356	-	3685
171	79,07	0,42	22,1	406	-	3936

IBA53

Mn ₂ [Nm]	i	Pn ₁ [kW]	n ₂ [rpm]	Fr1 [N]	Fr2 D-S-P [N]	Fr2 C [N]
189	73,70	0,52	23,7	472	-	3845
186	93,33	0,41	18,8	472	-	4000
187	111,61	0,34	15,7	472	-	4000
186	136,53	0,28	12,8	472	-	4000
190	172,53	0,22	10,1	472	-	4000
186	197,11	0,19	8,9	472	-	4000
183	249,08	0,15	7,0	472	-	4000

IBA53

Mn ₂ [Nm]	i	Pn ₁ [kW]	n ₂ [rpm]	Fr1 [N]	Fr2 D-S-P [N]	Fr2 C [N]
185	271,16	0,14	6,5	472	-	4000
180	342,65	0,11	5,1	472	-	4000

IBA72

Mn ₂ [Nm]	i	Pn ₁ [kW]	n ₂ [rpm]	Fr1 [N]	Fr2 D-S-P [N]	Fr2 C [N]
298	8,36	6,88	209,4	664	4715	2357
298	10,06	5,71	174,0	685	5016	2508
298	12,44	4,62	140,6	667	5384	2692
358	14,91	4,63	117,4	826	5718	2859
358	17,94	3,85	97,5	685	6083	3041
358	22,19	3,11	78,8	667	6529	3265
358	27,45	2,52	63,8	667	7009	3504
358	33,04	2,09	53,0	685	7456	3728
340	40,87	1,60	42,8	635	8003	4002
298	45,64	1,26	38,3	646	8303	4152
298	54,94	1,05	31,9	685	8833	4416
296	67,96	0,84	25,8	667	9481	4741

IBA73

Mn ₂ [Nm]	i	Pn ₁ [kW]	n ₂ [rpm]	Fr1 [N]	Fr2 D-S-P [N]	Fr2 C [N]
384	43,89	1,78	39,9	330	8196	4098
384	52,83	1,48	33,1	411	8718	4359
382	65,35	1,19	26,8	400	9358	4679
384	80,83	0,97	21,6	400	10000	5023
382	97,29	0,80	18,0	411	10000	5343
384	120,34	0,65	14,5	400	10000	5500
384	149,73	0,52	11,7	398	10000	5500
386	180,23	0,44	9,7	411	10000	5500
384	222,93	0,35	7,8	400	10000	5500
382	260,20	0,30	6,7	424	10000	5500
388	321,85	0,25	5,4	400	10000	5500
374	357,95	0,21	4,9	445	10000	5500
394	442,76	0,18	4,0	400	10000	5500

IB063

Mn ₂ [Nm]	i	Pn ₁ [kW]	n ₂ [rpm]	Fr1 [N]	Fr2 D-S-P [N]	Fr2 C [N]
191	5,71	6,80	306,2	367	6520	1863

IB063

Mn ₂ [Nm]	i	Pn ₁ [kW]	n ₂ [rpm]	Fr1 [N]	Fr2 D-S-P [N]	Fr2 C [N]
243	6,88	7,20	254,4	388	6797	1942
252	7,32	7,01	239,0	415	6927	1979
256	9,16	5,70	191,0	375	7105	2030
277	10,26	5,50	170,5	368	7197	2056
325	11,03	6,00	158,7	395	7337	2096
334	12,35	5,50	141,7	428	7536	2153
362	13,15	5,60	133,1	462	7702	2200
426	15,18	5,72	115,3	559	8195	2341
432	17,00	5,17	102,9	618	8562	2446
432	22,39	3,93	78,2	756	9618	2748
432	26,09	3,37	67,1	817	10248	2928
432	28,03	3,14	62,4	843	10554	3016
432	33,43	2,63	52,3	899	11338	3240
432	38,58	2,28	45,4	938	12000	3431
432	43,22	2,04	40,5	965	12000	3590
510	50,81	2,04	34,4	999	12000	3827
510	56,93	1,82	30,7	1020	12000	4001
510	69,16	1,50	25,3	1050	12000	4315
510	77,48	1,34	22,6	1065	12000	4508
510	90,33	1,15	19,4	1083	12000	4779
510	101,20	1,03	17,3	1095	12000	4990
510	111,74	0,93	15,7	1104	12000	5180
510	124,20	0,84	14,1	1113	12000	5390
510	139,15	0,75	12,6	1121	12000	5623
510	157,42	0,66	11,1	1129	12000	5887

IB083

Mn ₂ [Nm]	i	Pn ₁ [kW]	n ₂ [rpm]	Fr1 [N]	Fr2 D-S-P [N]	Fr2 C [N]
330	7,81	8,60	224,1	1764	11107	3173
347	8,62	8,20	202,9	1657	11159	3188
468	10,49	9,08	166,8	1804	11869	3391
489	11,59	8,60	151,0	1750	11965	3419
524	14,43	7,40	121,3	1916	12849	3671
610	16,60	7,48	105,5	2011	13450	3843
610	18,32	6,78	95,5	2104	14004	4001
610	22,82	5,44	76,7	2281	15298	4371
610	26,71	4,65	65,5	2386	16288	4654
610	29,50	4,21	59,3	2444	16936	4839
610	31,80	3,91	55,0	2484	17443	4984
610	34,49	3,60	50,7	2500	18000	5144
610	39,60	3,14	44,2	2500	18000	5427

IB083

Mn ₂ [Nm]	i	Pn ₁ [kW]	n ₂ [rpm]	Fr1 [N]	Fr2 D-S-P [N]	Fr2 C [N]
610	42,95	2,89	40,7	2500	18000	5600
610	45,44	2,73	38,5	2500	18000	5722
725	51,19	2,88	34,2	2500	18000	5989
725	55,52	2,66	31,5	2500	18000	6177
725	59,96	2,46	29,2	2500	18000	6359
725	63,74	2,32	27,4	2500	18000	6507
725	69,14	2,13	25,3	2500	18000	6710
725	73,14	2,02	23,9	2500	18000	6853
725	80,76	1,83	21,7	2500	18000	7111
725	92,19	1,60	19,0	2500	18000	7470
725	100,57	1,47	17,4	2500	18000	7714
725	105,29	1,40	16,6	2500	18000	7846
725	116,25	1,27	15,1	2500	18000	8137
725	126,76	1,16	13,8	2500	18000	8400
725	144,77	1,02	12,1	2500	18000	8818

IB103

Mn ₂ [Nm]	i	Pn ₁ [kW]	n ₂ [rpm]	Fr1 [N]	Fr2 D-S-P [N]	Fr2 C [N]
1001	17,27	11,80	101,3	1508	16670	4763
1010	19,06	10,79	91,8	1646	17345	4956
1010	23,70	8,68	73,8	1907	18922	5406
1080	26,51	8,29	66,0	1953	19508	5574
1155	30,55	7,70	57,3	2029	20367	5819
1225	33,07	7,54	52,9	2047	20749	5928
1225	35,87	6,95	48,8	2120	21439	6125
1225	41,12	6,07	42,5	2230	22000	6469
1225	44,61	5,59	39,2	2288	22000	6680
1225	47,28	5,27	37,0	2327	22000	6835
1450	50,24	5,88	34,8	2366	22000	7000
1450	53,02	5,57	33,0	2398	22000	7149
1450	58,50	5,05	29,9	2453	22000	7429
1450	64,89	4,55	27,0	2505	22000	7732
1450	68,58	4,31	25,5	2530	22000	7899
1450	72,76	4,06	24,1	2556	22000	8081
1450	78,92	3,74	22,2	2589	22000	8336
1535	83,66	3,74	20,9	2590	22000	8446
1535	92,31	3,39	19,0	2626	22000	8771
1535	105,44	2,96	16,6	2671	22000	9227
1535	114,80	2,72	15,2	2696	22000	9529
1535	120,42	2,60	14,5	2709	22000	9703
1535	132,87	2,35	13,2	2735	22000	10069

IB103

Mn ₂ [Nm]	i	Pn ₁ [kW]	n ₂ [rpm]	Fr1 [N]	Fr2 D-S-P [N]	Fr2 C [N]
1535	144,69	2,16	12,1	2755	22000	10396
1535	165,25	1,89	10,6	2783	22000	10924

IB123

Mn ₂ [Nm]	i	Pn ₁ [kW]	n ₂ [rpm]	Fr1 [N]	Fr2 D-S-P [N]	Fr2 C [N]
696	7,97	17,80	219,7	2647	16004	4572
784	9,62	16,60	181,9	2656	16152	4615
1010	10,33	19,90	169,3	2610	15860	4531
1097	12,48	17,90	140,2	2849	17434	4981
1163	13,84	17,10	126,4	2910	17910	5117
1511	15,38	20,00	113,8	3019	18865	5390
1590	18,58	17,43	94,2	3150	20227	5779
1751	20,61	17,30	84,9	3129	19967	5705
1824	22,78	16,30	76,8	3117	19706	5630
2020	25,89	15,89	67,6	3223	21077	6022
2020	27,51	14,95	63,6	3269	21748	6214
2020	30,79	13,36	56,8	3347	23031	6580
2020	31,26	13,16	56,0	3357	23207	6631
2020	34,68	11,86	50,5	3421	24438	6982
2020	40,53	10,15	43,2	3504	26365	7533
2165	44,89	9,82	39,0	3521	26820	7663
2310	49,80	9,44	35,1	3539	27343	7812
2730	54,30	10,24	32,2	3577	28534	8153
2730	59,36	9,36	29,5	3613	29797	8514
2820	62,59	9,17	28,0	3622	30000	8610
2815	69,43	8,25	25,2	3659	30000	9052
2990	74,42	8,18	23,5	3663	30000	9109
2990	80,04	7,61	21,9	3687	30000	9436
2990	89,87	6,77	19,5	3721	30000	9971
2990	99,70	6,11	17,6	3749	30000	10470
2990	106,65	5,71	16,4	3765	30000	10802
2990	119,60	5,09	14,6	3791	30000	11385
2990	129,96	4,68	13,5	3808	30000	11822
2990	144,43	4,22	12,1	3827	30000	12394
2990	160,23	3,80	10,9	3844	30000	12976
2990	180,40	3,37	9,7	3862	30000	13667

IB143

Mn ₂ [Nm]	i	Pn ₁ [kW]	n ₂ [rpm]	Fr1 [N]	Fr2 D-S-P [N]	Fr2 C [N]
1411	10,84	26,50	161,4	2401	14322	14322
1457	11,87	25,00	147,5	2491	14730	14730
1579	14,49	22,20	120,8	2764	16364	16364
2276	17,04	27,20	102,7	2916	17477	17477
2346	18,66	25,60	93,8	2886	17100	17100
2186	21,00	21,20	83,3	2900	17009	17009
2628	22,77	23,50	76,8	2885	16597	16597
2429	25,63	19,30	68,3	2964	17182	17182
3325	27,44	24,67	63,8	3033	17889	17889
3395	30,05	23,01	58,2	3098	18551	18551
3395	33,01	20,94	53,0	3179	19580	19580
3470	36,67	19,27	47,7	3245	20470	20470
3470	40,29	17,54	43,4	3313	21570	21570
3470	44,16	16,00	39,6	3374	22675	22675
3615	48,35	15,22	36,2	3404	23201	23201
4270	53,16	16,36	32,9	3458	24414	24414
4270	54,63	15,92	32,0	3473	24770	24770
4270	59,02	14,73	29,6	3512	25798	25798
4270	64,88	13,40	27,0	3557	27093	27093
4270	70,43	12,34	24,9	3592	28249	28249
4270	77,12	11,27	22,7	3627	29562	29562
4270	85,54	10,16	20,5	3664	31114	31114
4270	94,13	9,24	18,6	3695	32591	32591
4270	105,83	8,22	16,5	3729	34468	34468
4270	111,94	7,77	15,6	3744	35392	35392
4270	124,62	6,98	14,0	3770	37208	37208
4270	136,44	6,37	12,8	3790	38793	38793
4270	149,59	5,81	11,7	3809	40000	40000
4270	166,53	5,22	10,5	3829	40000	40000
4270	187,24	4,64	9,3	3848	40000	40000

IB153

Mn ₂ [Nm]	i	Pn ₁ [kW]	n ₂ [rpm]	Fr1 [N]	Fr2 D-S-P [N]	Fr2 C [N]
2072	10,49	40,20	166,8	7203	30265	30265
2272	12,64	36,60	138,4	7657	32579	32579
2395	14,01	34,80	124,9	7651	33227	33227
3177	15,40	42,00	113,6	7852	34499	34499
3454	18,56	37,90	94,3	7860	35747	35747
3606	20,56	35,70	85,1	7905	36575	36575
3738	23,86	31,90	73,3	8125	38588	38588
4886	25,19	39,50	69,5	8193	39314	39314

IB153

Mn ₂ [Nm]	i	Pn ₁ [kW]	n ₂ [rpm]	Fr1 [N]	Fr2 D-S-P [N]	Fr2 C [N]
4811	28,23	34,70	62,0	8109	39527	39527
5351	30,35	35,90	57,7	8232	40748	40748
5650	33,63	34,20	52,0	8393	42534	42534
5572	35,02	32,40	50,0	8451	43252	43252
5785	38,81	30,35	45,1	8590	45125	45125
5785	42,30	27,85	41,4	8696	46743	46743
5780	47,53	24,76	36,8	8826	49012	49012
6835	50,56	27,52	34,6	8889	50248	50248
6835	54,64	25,47	32,0	8963	51837	51837
6835	57,27	24,30	30,6	9005	52821	52821
6835	60,92	22,84	28,7	9057	54136	54136
6835	63,47	21,93	27,6	9090	55024	55024
6835	71,15	19,56	24,6	9174	57559	57559
6835	77,22	18,02	22,7	9229	59440	59440
6835	83,89	16,59	20,9	9281	61391	61391
6835	87,65	15,88	20,0	9306	62448	62448
6835	93,05	14,96	18,8	9339	63911	63911
6835	103,12	13,50	17,0	9392	65000	65000
6835	123,88	11,23	14,1	9473	65000	65000
6835	134,27	10,36	13,0	9504	65000	65000
6835	149,26	9,32	11,7	9541	65000	65000
6835	165,42	8,41	10,6	9574	65000	65000

IB163

Mn ₂ [Nm]	i	Pn ₁ [kW]	n ₂ [rpm]	Fr1 [N]	Fr2 D-S-P [N]	Fr2 C [N]
2114	8,89	48,40	196,8	7268	42738	42738
2441	10,58	47,00	165,5	7338	44107	44107
3626	11,87	62,20	147,4	7730	46651	46651
3460	12,81	55,00	136,6	7578	46354	46354
3680	14,08	53,20	124,3	7599	46974	46974
4208	15,52	55,20	112,8	7748	48363	48363
4780	16,39	59,40	106,8	7908	49696	49696
4982	18,02	56,30	97,1	8015	50972	50972
5587	19,96	57,00	87,7	8179	52815	52815
4915	21,94	45,60	79,8	8428	55548	55548
6173	24,17	52,00	72,4	8585	57740	57740
6423	26,58	49,20	65,8	8652	59139	59139
7375	28,80	52,14	60,8	8905	62694	62694
7822	30,92	51,50	56,6	8835	62446	62446
8600	34,25	51,12	51,1	8932	64581	64581
8890	37,66	48,06	46,5	9015	66599	65000

IB163

Mn_2 [Nm]	i	Pn_1 [kW]	n2 [rpm]	Fr1 [N]	Fr2 D-S-P [N]	Fr2 C [N]
9180	40,65	45,98	43,0	9072	68159	65000
8675	45,09	39,17	38,8	9256	72405	65000
11110	51,00	44,35	34,3	9301	74583	65000
11110	53,63	42,18	32,6	9351	76188	65000
11110	58,97	38,36	29,7	9439	79289	65000
11110	69,78	32,42	25,1	9575	80000	65000
11110	76,72	29,49	22,8	9642	80000	65000
11110	87,54	25,84	20,0	9726	80000	65000
11110	96,25	23,50	18,2	9779	80000	65000
11110	103,93	21,77	16,8	9819	80000	65000
11110	114,27	19,80	15,3	9864	80000	65000
11110	126,29	17,91	13,9	9907	80000	65000
11110	138,85	16,29	12,6	9944	80000	65000
11110	154,83	14,61	11,3	9983	80000	65000

IBA42

Mn_2 [Nm]	i	Pn_1 [kW]	n2 [rpm]	Fr1 [N]	Fr2 D-S-P [N]	Fr2 C [N]
77	7,62	1,56	183,8	373	-	1814
77	10,62	1,12	131,8	355	-	2027
77	12,95	0,92	108,1	406	-	2165
77	14,46	0,82	96,8	443	-	2246
102	16,47	0,96	85,0	579	-	2346
103	22,97	0,69	60,9	355	-	2621
102	28,00	0,56	50,0	406	-	2800
102	31,27	0,50	44,8	443	-	2905
103	33,78	0,47	41,4	458	-	2981
102	47,12	0,33	29,7	355	-	3331
102	57,43	0,27	24,4	406	-	3558
92	64,13	0,22	21,8	406	-	3691
95	78,17	0,19	17,9	406	-	3943

IBA52

Mn_2 [Nm]	i	Pn_1 [kW]	n2 [rpm]	Fr1 [N]	Fr2 D-S-P [N]	Fr2 C [N]
137	7,91	2,67	176,9	373	-	1969
137	9,46	2,23	148,0	414	-	2090
136	11,57	1,81	121,0	405	-	2235
137	14,63	1,45	95,7	392	-	2416
171	17,11	1,54	81,8	529	-	2546
171	20,46	1,29	68,4	414	-	2702
170	25,03	1,05	55,9	405	-	2890
172	31,63	0,84	44,3	392	-	3124
171	35,10	0,75	39,9	446	-	3235
172	41,97	0,63	33,4	414	-	3433
188	51,34	0,57	27,3	445	-	3672
172	64,87	0,41	21,6	356	-	3970
171	79,07	0,33	17,7	406	-	4000

IBA53

Mn_2 [Nm]	i	Pn_1 [kW]	n2 [rpm]	Fr1 [N]	Fr2 D-S-P [N]	Fr2 C [N]
189	73,70	0,42	19,0	472	-	4000
186	93,33	0,32	15,0	472	-	4000
187	111,61	0,27	12,5	472	-	4000
186	136,53	0,22	10,2	472	-	4000
190	172,53	0,18	8,1	472	-	4000
186	197,11	0,15	7,1	472	-	4000
183	249,08	0,12	5,6	472	-	4000

IBA53

Mn ₂ [Nm]	i	Pn ₁ [kW]	n ₂ [rpm]	Fr1 [N]	Fr2 D-S-P [N]	Fr2 C [N]
185	271,16	0,11	5,2	472	-	4000
180	342,65	0,09	4,1	472	-	4000

IBA72

Mn ₂ [Nm]	i	Pn ₁ [kW]	n ₂ [rpm]	Fr1 [N]	Fr2 D-S-P [N]	Fr2 C [N]
298	8,36	5,50	167,5	664	5079	2540
298	10,06	4,57	139,2	685	5403	2701
298	12,44	3,70	112,5	667	5800	2900
358	14,91	3,71	93,9	826	6160	3080
358	17,94	3,08	78,0	685	6552	3276
358	22,19	2,49	63,1	667	7033	3517
358	27,45	2,01	51,0	667	7550	3775
358	33,04	1,67	42,4	685	8031	4016
340	40,87	1,28	34,2	635	8621	4311
298	45,64	1,01	30,7	646	8944	4472
298	54,94	0,84	25,5	685	9515	4757
296	67,96	0,67	20,6	667	10000	5107

IBA73

Mn ₂ [Nm]	i	Pn ₁ [kW]	n ₂ [rpm]	Fr1 [N]	Fr2 D-S-P [N]	Fr2 C [N]
384	43,89	1,43	31,9	330	8828	4414
384	52,83	1,18	26,5	411	9391	4696
382	65,35	0,95	21,4	400	10000	5041
384	80,83	0,77	17,3	400	10000	5411
382	97,29	0,64	14,4	411	10000	5500
384	120,34	0,52	11,6	400	10000	5500
384	149,73	0,42	9,3	398	10000	5500
386	180,23	0,35	7,8	411	10000	5500
384	222,93	0,28	6,3	400	10000	5500
382	260,20	0,24	5,4	424	10000	5500
388	321,85	0,20	4,3	400	10000	5500
374	357,95	0,17	3,9	445	10000	5500
394	442,76	0,14	3,2	400	10000	5500

IB063

Mn ₂ [Nm]	i	Pn ₁ [kW]	n ₂ [rpm]	Fr1 [N]	Fr2 D-S-P [N]	Fr2 C [N]
208	5,71	5,93	245,0	314	7034	2010

IB063

Mn ₂ [Nm]	i	Pn ₁ [kW]	n ₂ [rpm]	Fr1 [N]	Fr2 D-S-P [N]	Fr2 C [N]
244	6,88	5,78	203,5	337	7335	2096
252	7,32	5,61	191,2	365	7475	2136
321	9,16	5,70	152,8	323	7673	2192
347	10,26	5,50	136,4	315	7774	2221
390	11,03	5,76	127,0	345	7927	2265
417	12,35	5,50	113,3	380	8142	2326
426	13,15	5,28	106,5	416	8322	2378
426	15,18	4,57	92,3	519	8853	2529
432	17,00	4,14	82,3	581	9248	2642
432	22,39	3,14	62,5	728	10385	2967
432	26,09	2,70	53,7	794	11063	3161
432	28,03	2,51	49,9	821	11393	3255
432	33,43	2,10	41,9	881	12000	3496
432	38,58	1,82	36,3	922	12000	3703
432	43,22	1,63	32,4	951	12000	3874
510	50,81	1,63	27,6	987	12000	4129
510	56,93	1,46	24,6	1009	12000	4316
510	69,16	1,20	20,2	1041	12000	4654
510	77,48	1,07	18,1	1057	12000	4861
510	90,33	0,92	15,5	1076	12000	5154
510	101,20	0,82	13,8	1089	12000	5380
510	111,74	0,74	12,5	1098	12000	5585
510	124,20	0,67	11,3	1108	12000	5811
510	139,15	0,60	10,1	1116	12000	6062
510	157,42	0,53	8,9	1125	12000	6346

IB083

Mn ₂ [Nm]	i	Pn ₁ [kW]	n ₂ [rpm]	Fr1 [N]	Fr2 D-S-P [N]	Fr2 C [N]
360	7,81	7,51	179,3	1685	11980	3423
432	8,62	8,16	162,4	1571	12040	3440
468	10,49	7,26	133,4	1728	12807	3659
540	11,59	7,59	120,8	1671	12915	3690
585	14,43	6,60	97,0	1847	13870	3963
610	16,60	5,99	84,4	1948	14518	4148
610	18,32	5,42	76,4	2047	15115	4319
610	22,82	4,35	61,4	2235	16508	4717
610	26,71	3,72	52,4	2346	17573	5021
610	29,50	3,37	47,5	2408	18000	5220
610	31,80	3,12	44,0	2451	18000	5376
610	34,49	2,88	40,6	2494	18000	5549
610	39,60	2,51	35,4	2500	18000	5853

IB083

Mn ₂ [Nm]	i	Pn ₁ [kW]	n ₂ [rpm]	Fr1 [N]	Fr2 D-S-P [N]	Fr2 C [N]
610	42,95	2,31	32,6	2500	18000	6039
610	45,44	2,19	30,8	2500	18000	6171
725	51,19	2,31	27,4	2500	18000	6458
725	55,52	2,13	25,2	2500	18000	6660
725	59,96	1,97	23,4	2500	18000	6856
725	63,74	1,85	22,0	2500	18000	7016
725	69,14	1,71	20,2	2500	18000	7234
725	73,14	1,61	19,1	2500	18000	7388
725	80,76	1,46	17,3	2500	18000	7666
725	92,19	1,28	15,2	2500	18000	8052
725	100,57	1,17	13,9	2500	18000	8315
725	105,29	1,12	13,3	2500	18000	8457
725	116,25	1,02	12,0	2500	18000	8771
725	126,76	0,93	11,0	2500	18000	9053
725	144,77	0,82	9,7	2500	18000	9503

IB103

Mn ₂ [Nm]	i	Pn ₁ [kW]	n ₂ [rpm]	Fr1 [N]	Fr2 D-S-P [N]	Fr2 C [N]
1010	17,27	9,53	81,1	1414	17992	5141
1010	19,06	8,63	73,5	1561	18718	5348
1010	23,70	6,94	59,1	1839	20415	5833
1080	26,51	6,64	52,8	1887	21050	6014
1155	30,55	6,16	45,8	1969	21978	6279
1225	33,07	6,03	42,3	1987	22000	6398
1225	35,87	5,56	39,0	2065	22000	6610
1225	41,12	4,85	34,0	2182	22000	6979
1225	44,61	4,47	31,4	2244	22000	7207
1225	47,28	4,22	29,6	2286	22000	7374
1450	50,24	4,70	27,9	2327	22000	7552
1450	53,02	4,45	26,4	2361	22000	7712
1450	58,50	4,04	23,9	2419	22000	8013
1450	64,89	3,64	21,6	2474	22000	8340
1450	68,58	3,44	20,4	2502	22000	8519
1450	72,76	3,25	19,2	2529	22000	8715
1450	78,92	2,99	17,7	2564	22000	8990
1535	83,66	2,99	16,7	2565	22000	9109
1535	92,31	2,71	15,2	2604	22000	9459
1535	105,44	2,37	13,3	2651	22000	9950
1535	114,80	2,18	12,2	2678	22000	10275
1535	120,42	2,08	11,6	2692	22000	10462
1535	132,87	1,88	10,5	2719	22000	10856

IB103

Mn ₂ [Nm]	i	Pn ₁ [kW]	n ₂ [rpm]	Fr1 [N]	Fr2 D-S-P [N]	Fr2 C [N]
1535	144,69	1,73	9,7	2740	22000	11208
1535	165,25	1,51	8,5	2770	22000	11776

IB123

Mn ₂ [Nm]	i	Pn ₁ [kW]	n ₂ [rpm]	Fr1 [N]	Fr2 D-S-P [N]	Fr2 C [N]
871	7,97	17,80	175,8	2561	17308	4945
980	9,62	16,60	145,5	2570	17484	4995
1263	10,33	19,90	135,5	2521	17181	4909
1371	12,48	17,90	112,2	2775	18875	5393
1453	13,84	17,10	101,1	2841	19393	5541
1515	15,38	16,04	91,0	2957	20420	5834
1590	18,58	13,94	75,4	3095	21892	6255
1805	20,61	14,27	67,9	3073	21629	6180
2020	22,78	14,44	61,5	3061	21364	6104
2020	25,89	12,71	54,1	3174	22840	6526
2020	27,51	11,96	50,9	3223	23562	6732
2020	30,79	10,69	45,5	3306	24944	7127
2020	31,26	10,52	44,8	3316	25133	7181
2020	34,68	9,49	40,4	3384	26458	7559
2020	40,53	8,12	34,5	3473	28532	8152
2165	44,89	7,86	31,2	3490	29033	8295
2310	49,80	7,56	28,1	3510	29606	8459
2730	54,30	8,19	25,8	3550	30000	8825
2730	59,36	7,49	23,6	3589	30000	9214
2820	62,59	7,34	22,4	3598	30000	9319
2815	69,43	6,60	20,2	3638	30000	9795
2990	74,42	6,54	18,8	3641	30000	9859
2990	80,04	6,08	17,5	3667	30000	10211
2990	89,87	5,42	15,6	3703	30000	10788
2990	99,70	4,89	14,0	3733	30000	11324
2990	106,65	4,57	13,1	3750	30000	11682
2990	119,60	4,07	11,7	3777	30000	12309
2990	129,96	3,75	10,8	3795	30000	12780
2990	144,43	3,37	9,7	3816	30000	13395
2990	160,23	3,04	8,7	3834	30000	14022
2990	180,40	2,70	7,8	3853	30000	14766

IB143

Mn ₂ [Nm]	i	Pn ₁ [kW]	n ₂ [rpm]	Fr1 [N]	Fr2 D-S-P [N]	Fr2 C [N]
1763	10,84	26,50	129,2	2299	15530	15530
1821	11,87	25,00	118,0	2395	15973	15973
1974	14,49	22,20	96,7	2685	17731	17731
2310	17,04	22,08	82,2	2847	18933	18933
2600	18,66	22,70	75,0	2815	18542	18542
2733	21,00	21,20	66,7	2830	18460	18460
3180	22,77	22,75	61,5	2813	18031	18031
3036	25,63	19,30	54,6	2898	18668	18668
3325	27,44	19,74	51,0	2971	19429	19429
3395	30,05	18,41	46,6	3040	20146	20146
3395	33,01	16,75	42,4	3126	21254	21254
3470	36,67	15,41	38,2	3197	22216	22216
3470	40,29	14,03	34,8	3269	23399	23399
3470	44,16	12,80	31,7	3334	24589	24589
3615	48,35	12,18	28,9	3366	25162	25162
4270	53,16	13,08	26,3	3424	26469	26469
4270	54,63	12,73	25,6	3439	26852	26852
4270	59,02	11,79	23,7	3481	27958	27958
4270	64,88	10,72	21,6	3528	29352	29352
4270	70,43	9,87	19,9	3566	30597	30597
4270	77,12	9,02	18,1	3603	32010	32010
4270	85,54	8,13	16,4	3643	33680	33680
4270	94,13	7,39	14,9	3675	35271	35271
4270	105,83	6,57	13,2	3712	37290	37290
4270	111,94	6,21	12,5	3728	38286	38286
4270	124,62	5,58	11,2	3755	40000	40000
4270	136,44	5,10	10,3	3777	40000	40000
4270	149,59	4,65	9,4	3797	40000	40000
4270	166,53	4,18	8,4	3818	40000	40000
4270	187,24	3,71	7,5	3838	40000	40000

IB153

Mn ₂ [Nm]	i	Pn ₁ [kW]	n ₂ [rpm]	Fr1 [N]	Fr2 D-S-P [N]	Fr2 C [N]
2590	10,49	40,20	133,4	7032	32656	32656
2841	12,64	36,60	110,7	7516	35147	35147
2993	14,01	34,80	99,9	7509	35853	35853
3615	15,40	38,24	90,9	7723	37222	37222
4317	18,56	37,90	75,5	7732	38582	38582
4507	20,56	35,70	68,1	7780	39483	39483
4672	23,86	31,90	58,7	8014	41653	41653
4915	25,19	31,79	55,6	8085	42436	42436

IB153

Mn ₂ [Nm]	i	Pn ₁ [kW]	n ₂ [rpm]	Fr1 [N]	Fr2 D-S-P [N]	Fr2 C [N]
5780	28,23	33,35	49,6	7997	42686	42686
5780	30,35	31,02	46,1	8128	44001	44001
5780	33,63	27,99	41,6	8298	45923	45923
5785	35,02	26,91	40,0	8361	46696	46696
5785	38,81	24,28	36,1	8509	48712	48712
5785	42,30	22,28	33,1	8621	50453	50453
5780	47,53	19,81	29,4	8759	52896	52896
6835	50,56	22,02	27,7	8826	54227	54227
6835	54,64	20,38	25,6	8904	55937	55937
6835	57,27	19,44	24,4	8949	56996	56996
6835	60,92	18,27	23,0	9005	58412	58412
6835	63,47	17,54	22,1	9039	59367	59367
6835	71,15	15,65	19,7	9130	62097	62097
6835	77,22	14,42	18,1	9188	64121	64121
6835	83,89	13,27	16,7	9243	65000	65000
6835	87,65	12,70	16,0	9270	65000	65000
6835	93,05	11,97	15,1	9305	65000	65000
6835	103,12	10,80	13,6	9361	65000	65000
6835	123,88	8,99	11,3	9447	65000	65000
6835	134,27	8,29	10,4	9480	65000	65000
6835	149,26	7,46	9,4	9520	65000	65000
6835	165,42	6,73	8,5	9554	65000	65000

IB163

Mn ₂ [Nm]	i	Pn ₁ [kW]	n ₂ [rpm]	Fr1 [N]	Fr2 D-S-P [N]	Fr2 C [N]
2642	8,89	48,40	157,4	7073	46145	46145
3052	10,58	47,00	132,4	7148	47640	47640
4533	11,87	62,20	118,0	7565	50376	50376
4325	12,81	55,00	109,3	7403	50078	50078
4600	14,08	53,20	99,4	7426	50762	50762
5260	15,52	55,20	90,2	7584	52265	52265
5975	16,39	59,40	85,4	7754	53698	53698
6227	18,02	56,30	77,7	7869	55082	55082
6984	19,96	57,00	70,2	8043	57072	57072
6143	21,94	45,60	63,8	8307	60008	60008
7590	24,17	51,14	57,9	8475	62369	62369
8025	26,58	49,18	52,7	8546	63887	63887
7375	28,80	41,71	48,6	8815	67696	65000
8315	30,92	43,80	45,3	8740	67456	65000
8600	34,25	40,90	40,9	8844	69762	65000
8890	37,66	38,45	37,2	8932	71943	65000

IB163

Mn_2 [Nm]	i	Pn_1 [kW]	n_2 [rpm]	Fr1 [N]	Fr2 D-S-P [N]	Fr2 C [N]
9180	40,65	36,78	34,4	8992	73630	65000
8675	45,09	31,34	31,1	9189	78186	65000
11110	51,00	35,48	27,4	9236	80000	65000
11110	53,63	33,74	26,1	9289	80000	65000
11110	58,97	30,69	23,7	9382	80000	65000
11110	69,78	25,94	20,1	9527	80000	65000
11110	76,72	23,59	18,2	9599	80000	65000
11110	87,54	20,67	16,0	9688	80000	65000
11110	96,25	18,80	14,6	9745	80000	65000
11110	103,93	17,41	13,5	9787	80000	65000
11110	114,27	15,84	12,2	9835	80000	65000
11110	126,29	14,33	11,1	9881	80000	65000
11110	138,85	13,03	10,1	9921	80000	65000
11110	154,83	11,69	9,0	9962	80000	65000

IBA42

Mn ₂ [Nm]	i	Pn ₁ [kW]	n ₂ [rpm]	Fr1 [N]	Fr2 D-S-P [N]	Fr2 C [N]
77	7,62	1,26	149,7	373	-	1943
77	10,62	0,90	107,3	355	-	2171
77	12,95	0,74	88,0	406	-	2319
77	14,46	0,66	78,8	443	-	2406
102	16,47	0,77	69,2	579	-	2512
103	22,97	0,56	49,6	355	-	2807
102	28,00	0,45	40,7	406	-	2998
102	31,27	0,41	36,5	443	-	3111
103	33,78	0,38	33,8	458	-	3192
102	47,12	0,27	24,2	355	-	3567
102	57,43	0,22	19,9	406	-	3810
92	64,13	0,18	17,8	406	-	3952
95	78,17	0,15	14,6	406	-	4000

IBA52

Mn ₂ [Nm]	i	Pn ₁ [kW]	n ₂ [rpm]	Fr1 [N]	Fr2 D-S-P [N]	Fr2 C [N]
137	7,91	2,15	144,1	373	-	2108
137	9,46	1,80	120,5	414	-	2238
136	11,57	1,46	98,5	405	-	2393
137	14,63	1,17	77,9	392	-	2587
171	17,11	1,24	66,6	529	-	2726
171	20,46	1,04	55,7	414	-	2894
170	25,03	0,84	45,5	405	-	3095
172	31,63	0,68	36,0	392	-	3346
171	35,10	0,61	32,5	446	-	3464
172	41,97	0,51	27,2	414	-	3677
188	51,34	0,46	22,2	445	-	3932
172	64,87	0,33	17,6	356	-	4000
171	79,07	0,27	14,4	406	-	4000

IBA53

Mn ₂ [Nm]	i	Pn ₁ [kW]	n ₂ [rpm]	Fr1 [N]	Fr2 D-S-P [N]	Fr2 C [N]
189	73,70	0,34	15,5	472	-	4000
186	93,33	0,26	12,2	472	-	4000
187	111,61	0,22	10,2	472	-	4000
186	136,53	0,18	8,3	472	-	4000
190	172,53	0,14	6,6	472	-	4000
186	197,11	0,12	5,8	472	-	4000
183	249,08	0,10	4,6	472	-	4000

IBA53

Mn ₂ [Nm]	i	Pn ₁ [kW]	n ₂ [rpm]	Fr1 [N]	Fr2 D-S-P [N]	Fr2 C [N]
185	271,16	0,09	4,2	472	-	4000
180	342,65	0,07	3,3	472	-	4000

IBA72

Mn ₂ [Nm]	i	Pn ₁ [kW]	n ₂ [rpm]	Fr1 [N]	Fr2 D-S-P [N]	Fr2 C [N]
298	8,36	4,44	136,4	664	5439	2720
298	10,06	3,69	113,3	685	5786	2893
298	12,44	2,98	91,6	667	6211	3105
358	14,91	2,99	76,5	826	6596	3298
358	17,94	2,48	63,5	685	7017	3508
358	22,19	2,01	51,4	667	7532	3766
358	27,45	1,62	41,5	667	8085	4043
358	33,04	1,35	34,5	685	8600	4300
340	40,87	1,03	27,9	635	9232	4616
298	45,64	0,81	25,0	646	9578	4789
298	54,94	0,67	20,8	685	10000	5095
296	67,96	0,54	16,8	667	10000	5469

IBA73

Mn ₂ [Nm]	i	Pn ₁ [kW]	n ₂ [rpm]	Fr1 [N]	Fr2 D-S-P [N]	Fr2 C [N]
384	43,89	1,15	26,0	330	9454	4727
384	52,83	0,95	21,6	411	10000	5028
382	65,35	0,77	17,4	400	10000	5398
384	80,83	0,62	14,1	400	10000	5500
382	97,29	0,52	11,7	411	10000	5500
384	120,34	0,42	9,5	400	10000	5500
384	149,73	0,34	7,6	398	10000	5500
386	180,23	0,28	6,3	411	10000	5500
384	222,93	0,23	5,1	400	10000	5500
382	260,20	0,19	4,4	424	10000	5500
388	321,85	0,16	3,5	400	10000	5500
374	357,95	0,14	3,2	445	10000	5500
394	442,76	0,12	2,6	400	10000	5500

IB063

Mn ₂ [Nm]	i	Pn ₁ [kW]	n ₂ [rpm]	Fr1 [N]	Fr2 D-S-P [N]	Fr2 C [N]
208	5,71	4,78	199,5	292	7587	2168

IB063

Mn ₂ [Nm]	i	Pn ₁ [kW]	n ₂ [rpm]	Fr1 [N]	Fr2 D-S-P [N]	Fr2 C [N]
244	6,88	4,66	165,7	316	7919	2263
252	7,32	4,52	155,7	344	8070	2306
332	9,16	4,76	124,4	301	8305	2373
374	10,26	4,79	111,1	294	8426	2407
390	11,03	4,64	103,4	324	8593	2455
418	12,35	4,44	92,3	359	8832	2523
426	13,15	4,25	86,7	396	9025	2579
426	15,18	3,69	75,1	502	9594	2741
432	17,00	3,34	67,0	566	10019	2863
432	22,39	2,53	50,9	716	11236	3210
432	26,09	2,17	43,7	784	11961	3417
432	28,03	2,02	40,7	812	12000	3518
432	33,43	1,70	34,1	873	12000	3776
432	38,58	1,47	29,6	915	12000	3997
432	43,22	1,31	26,4	945	12000	4181
510	50,81	1,32	22,4	982	12000	4453
510	56,93	1,18	20,0	1004	12000	4654
510	69,16	0,97	16,5	1037	12000	5015
510	77,48	0,86	14,7	1054	12000	5237
510	90,33	0,74	12,6	1073	12000	5550
510	101,20	0,66	11,3	1086	12000	5793
510	111,74	0,60	10,2	1096	12000	6012
510	124,20	0,54	9,2	1105	12000	6253
510	139,15	0,48	8,2	1115	12000	6522
510	157,42	0,43	7,2	1123	12000	6826

IB083

Mn ₂ [Nm]	i	Pn ₁ [kW]	n ₂ [rpm]	Fr1 [N]	Fr2 D-S-P [N]	Fr2 C [N]
360	7,81	6,05	146,0	1652	12911	3689
432	8,62	6,58	132,2	1535	12995	3713
468	10,49	5,86	108,6	1696	13824	3950
540	11,59	6,12	98,4	1638	13958	3988
585	14,43	5,32	79,0	1818	14991	4283
610	16,60	4,83	68,7	1922	15692	4483
610	18,32	4,37	62,2	2023	16331	4666
610	22,82	3,51	50,0	2216	17821	5092
610	26,71	3,00	42,7	2330	18000	5417
610	29,50	2,72	38,6	2393	18000	5631
610	31,80	2,52	35,9	2437	18000	5798
610	34,49	2,32	33,0	2481	18000	5983
610	39,60	2,02	28,8	2500	18000	6308

IB083

Mn ₂ [Nm]	i	Pn ₁ [kW]	n ₂ [rpm]	Fr1 [N]	Fr2 D-S-P [N]	Fr2 C [N]
610	42,95	1,87	26,5	2500	18000	6507
610	45,44	1,76	25,1	2500	18000	6648
725	51,19	1,86	22,3	2500	18000	6955
725	55,52	1,71	20,5	2500	18000	7172
725	59,96	1,59	19,0	2500	18000	7382
725	63,74	1,49	17,9	2500	18000	7553
725	69,14	1,38	16,5	2500	18000	7786
725	73,14	1,30	15,6	2500	18000	7950
725	80,76	1,18	14,1	2500	18000	8248
725	92,19	1,03	12,4	2500	18000	8661
725	100,57	0,95	11,3	2500	18000	8943
725	105,29	0,90	10,8	2500	18000	9095
725	116,25	0,82	9,8	2500	18000	9430
725	126,76	0,75	9,0	2500	18000	9733
725	144,77	0,66	7,9	2500	18000	10214

IB103

Mn ₂ [Nm]	i	Pn ₁ [kW]	n ₂ [rpm]	Fr1 [N]	Fr2 D-S-P [N]	Fr2 C [N]
1010	17,27	7,68	66,0	1375	19436	5553
1010	19,06	6,96	59,8	1525	20213	5775
1010	23,70	5,60	48,1	1810	22000	6294
1080	26,51	5,35	43,0	1860	22000	6492
1155	30,55	4,96	37,3	1943	22000	6779
1225	33,07	4,86	34,5	1962	22000	6910
1225	35,87	4,48	31,8	2042	22000	7137
1225	41,12	3,91	27,7	2162	22000	7532
1225	44,61	3,61	25,6	2226	22000	7776
1225	47,28	3,40	24,1	2268	22000	7955
1450	50,24	3,79	22,7	2310	22000	8144
1450	53,02	3,59	21,5	2345	22000	8316
1450	58,50	3,25	19,5	2405	22000	8638
1450	64,89	2,93	17,6	2462	22000	8988
1450	68,58	2,78	16,6	2490	22000	9180
1450	72,76	2,62	15,7	2518	22000	9389
1450	78,92	2,41	14,4	2554	22000	9683
1535	83,66	2,41	13,6	2554	22000	9815
1535	92,31	2,18	12,3	2594	22000	10189
1535	105,44	1,91	10,8	2642	22000	10714
1535	114,80	1,76	9,9	2670	22000	11062
1535	120,42	1,67	9,5	2685	22000	11262
1535	132,87	1,52	8,6	2712	22000	11684

IB103

Mn ₂ [Nm]	i	Pn ₁ [kW]	n ₂ [rpm]	Fr1 [N]	Fr2 D-S-P [N]	Fr2 C [N]
1535	144,69	1,39	7,9	2734	22000	12061
1535	165,25	1,22	6,9	2765	22000	12669

IB123

Mn ₂ [Nm]	i	Pn ₁ [kW]	n ₂ [rpm]	Fr1 [N]	Fr2 D-S-P [N]	Fr2 C [N]
1080	7,97	17,80	143,1	2525	18833	5381
1216	9,62	16,60	118,5	2534	19084	5452
1445	10,33	18,36	110,3	2484	18801	5372
1445	12,48	15,21	91,3	2745	20614	5890
1515	13,84	14,37	82,3	2812	21189	6054
1515	15,38	12,93	74,1	2931	22289	6368
1590	18,58	11,24	61,4	3073	23884	6824
1805	20,61	11,50	55,3	3050	23665	6761
2020	22,78	11,64	50,0	3037	23443	6698
2020	25,89	10,25	44,0	3153	25023	7149
2020	27,51	9,64	41,4	3203	25796	7370
2020	30,79	8,61	37,0	3288	27274	7793
2020	31,26	8,48	36,5	3299	27477	7851
2020	34,68	7,65	32,9	3368	28895	8256
2020	40,53	6,54	28,1	3459	30000	8890
2165	44,89	6,33	25,4	3477	30000	9055
2310	49,80	6,09	22,9	3497	30000	9242
2730	54,30	6,60	21,0	3539	30000	9634
2730	59,36	6,04	19,2	3578	30000	10050
2820	62,59	5,92	18,2	3588	30000	10168
2815	69,43	5,32	16,4	3628	30000	10678
2990	74,42	5,28	15,3	3632	30000	10758
2990	80,04	4,91	14,2	3658	30000	11135
2990	89,87	4,37	12,7	3696	30000	11752
2990	99,70	3,94	11,4	3726	30000	12326
2990	106,65	3,68	10,7	3744	30000	12709
2990	119,60	3,28	9,5	3772	30000	13380
2990	129,96	3,02	8,8	3790	30000	13884
2990	144,43	2,72	7,9	3811	30000	14543
2990	160,23	2,45	7,1	3830	30000	15214
2990	180,40	2,18	6,3	3849	30000	16009

IB143

Mn ₂ [Nm]	i	Pn ₁ [kW]	n ₂ [rpm]	Fr1 [N]	Fr2 D-S-P [N]	Fr2 C [N]
2165	10,84	26,23	105,2	2257	17051	17051
2240	11,87	24,79	96,1	2355	17540	17540
2240	14,49	20,31	78,7	2653	19421	19421
2310	17,04	17,80	66,9	2818	20722	20722
2600	18,66	18,30	61,1	2785	20361	20361
2890	21,00	18,08	54,3	2801	20331	20331
3180	22,77	18,34	50,1	2784	19930	19930
3325	25,63	17,04	44,5	2870	20640	20640
3325	27,44	15,91	41,5	2945	21455	21455
3395	30,05	14,84	37,9	3016	22236	22236
3395	33,01	13,51	34,5	3104	23422	23422
3470	36,67	12,43	31,1	3177	24465	24465
3470	40,29	11,31	28,3	3251	25732	25732
3470	44,16	10,32	25,8	3317	27005	27005
3615	48,35	9,82	23,6	3350	27648	27648
4270	53,16	10,55	21,4	3409	29045	29045
4270	54,63	10,26	20,9	3425	29456	29456
4270	59,02	9,50	19,3	3468	30639	30639
4270	64,88	8,64	17,6	3516	32132	32132
4270	70,43	7,96	16,2	3555	33463	33463
4270	77,12	7,27	14,8	3593	34976	34976
4270	85,54	6,56	13,3	3634	36763	36763
4270	94,13	5,96	12,1	3667	38465	38465
4270	105,83	5,30	10,8	3704	40000	40000
4270	111,94	5,01	10,2	3721	40000	40000
4270	124,62	4,50	9,2	3749	40000	40000
4270	136,44	4,11	8,4	3771	40000	40000
4270	149,59	3,75	7,6	3792	40000	40000
4270	166,53	3,37	6,8	3813	40000	40000
4270	187,24	2,99	6,1	3834	40000	40000

IB153

Mn ₂ [Nm]	i	Pn ₁ [kW]	n ₂ [rpm]	Fr1 [N]	Fr2 D-S-P [N]	Fr2 C [N]
3212	10,49	40,20	108,7	6961	35245	35245
3250	12,64	33,76	90,2	7457	37910	37910
3615	14,01	33,88	81,4	7450	38700	38700
3615	15,40	30,83	74,0	7669	40164	40164
4335	18,56	30,68	61,4	7678	41686	41686
4695	20,56	29,98	55,4	7727	42683	42683
4845	23,86	26,67	47,8	7967	45019	45019
4915	25,19	25,63	45,3	8041	45863	45863

IB153

Mn ₂ [Nm]	i	Pn ₁ [kW]	n ₂ [rpm]	Fr1 [N]	Fr2 D-S-P [N]	Fr2 C [N]
5780	28,23	26,89	40,4	7950	46211	46211
5780	30,35	25,01	37,6	8084	47617	47617
5780	33,63	22,57	33,9	8259	49675	49675
5785	35,02	21,69	32,6	8323	50502	50502
5785	38,81	19,58	29,4	8474	52659	52659
5785	42,30	17,96	26,9	8590	54522	54522
5780	47,53	15,97	24,0	8731	57136	57136
6835	50,56	17,75	22,6	8800	58561	58561
6835	54,64	16,43	20,9	8880	60391	60391
6835	57,27	15,67	19,9	8926	61524	61524
6835	60,92	14,73	18,7	8983	63040	63040
6835	63,47	14,14	18,0	9019	64061	64061
6835	71,15	12,62	16,0	9111	65000	65000
6835	77,22	11,62	14,8	9171	65000	65000
6835	83,89	10,70	13,6	9227	65000	65000
6835	87,65	10,24	13,0	9255	65000	65000
6835	93,05	9,65	12,2	9291	65000	65000
6835	103,12	8,70	11,1	9348	65000	65000
6835	123,88	7,25	9,2	9436	65000	65000
6835	134,27	6,69	8,5	9470	65000	65000
6835	149,26	6,01	7,6	9511	65000	65000
6835	165,42	5,43	6,9	9546	65000	65000

IB163

Mn ₂ [Nm]	i	Pn ₁ [kW]	n ₂ [rpm]	Fr1 [N]	Fr2 D-S-P [N]	Fr2 C [N]
3277	8,89	48,40	128,2	6992	49918	49918
3785	10,58	47,00	107,8	7069	51605	51605
5565	11,87	61,57	96,0	7496	54517	54517
5365	12,81	55,00	89,0	7330	54285	54285
5705	14,08	53,20	81,0	7353	55080	55080
6524	15,52	55,20	73,5	7516	56720	56720
7160	16,39	57,38	69,6	7690	58246	58246
7520	18,02	54,81	63,3	7807	59766	59766
7735	19,96	50,90	57,1	7986	61920	61920
7515	21,94	44,97	52,0	8257	65037	65000
7590	24,17	41,23	47,2	8429	67572	65000
8025	26,58	39,65	42,9	8502	69244	65000
7375	28,80	33,63	39,6	8778	73249	65000
8315	30,92	35,31	36,9	8700	73095	65000
8600	34,25	32,97	33,3	8807	75594	65000
8890	37,66	31,00	30,3	8897	77959	65000

IB163

Mn_2 [Nm]	i	Pn_1 [kW]	n_2 [rpm]	Fr_1 [N]	Fr_2 D-S-P [N]	Fr_2 C [N]
9180	40,65	29,65	28,0	8959	79796	65000
8675	45,09	25,26	25,3	9160	80000	65000
11110	51,00	28,61	22,4	9209	80000	65000
11110	53,63	27,21	21,3	9264	80000	65000
11110	58,97	24,74	19,3	9359	80000	65000
11110	69,78	20,91	16,3	9508	80000	65000
11110	76,72	19,02	14,9	9581	80000	65000
11110	87,54	16,67	13,0	9672	80000	65000
11110	96,25	15,16	11,8	9730	80000	65000
11110	103,93	14,04	11,0	9774	80000	65000
11110	114,27	12,77	10,0	9823	80000	65000
11110	126,29	11,55	9,0	9870	80000	65000
11110	138,85	10,51	8,2	9911	80000	65000
11110	154,83	9,42	7,4	9953	80000	65000

IBA42

Mn ₂ [Nm]	i	Pn ₁ [kW]	n ₂ [rpm]	Fr1 [N]	Fr2 D-S-P [N]	Fr2 C [N]
77	7,62	0,99	118,2	373	-	2102
77	10,62	0,71	84,7	355	-	2349
77	12,95	0,58	69,5	406	-	2509
77	14,46	0,52	62,2	443	-	2603
102	16,47	0,61	54,6	579	-	2718
103	22,97	0,44	39,2	355	-	3037
102	28,00	0,36	32,1	406	-	3244
102	31,27	0,32	28,8	443	-	3366
103	33,78	0,30	26,6	458	-	3454
102	47,12	0,21	19,1	355	-	3859
102	57,43	0,17	15,7	406	-	4000
92	64,13	0,14	14,0	406	-	4000
95	78,17	0,12	11,5	406	-	4000

IBA52

Mn ₂ [Nm]	i	Pn ₁ [kW]	n ₂ [rpm]	Fr1 [N]	Fr2 D-S-P [N]	Fr2 C [N]
137	7,91	1,70	113,8	373	-	2281
137	9,46	1,42	95,1	414	-	2421
136	11,57	1,15	77,8	405	-	2589
137	14,63	0,92	61,5	392	-	2799
171	17,11	0,98	52,6	529	-	2950
171	20,46	0,82	44,0	414	-	3131
170	25,03	0,67	36,0	405	-	3349
172	31,63	0,53	28,4	392	-	3620
171	35,10	0,48	25,6	446	-	3748
172	41,97	0,40	21,4	414	-	3978
188	51,34	0,36	17,5	445	-	4000
172	64,87	0,26	13,9	356	-	4000
171	79,07	0,21	11,4	406	-	4000

IBA53

Mn ₂ [Nm]	i	Pn ₁ [kW]	n ₂ [rpm]	Fr1 [N]	Fr2 D-S-P [N]	Fr2 C [N]
189	73,70	0,27	12,2	472	-	4000
186	93,33	0,21	9,6	472	-	4000
187	111,61	0,17	8,1	472	-	4000
186	136,53	0,14	6,6	472	-	4000
190	172,53	0,11	5,2	472	-	4000
186	197,11	0,10	4,6	472	-	4000
183	249,08	0,08	3,6	472	-	4000

IBA53

Mn ₂ [Nm]	i	Pn ₁ [kW]	n ₂ [rpm]	Fr1 [N]	Fr2 D-S-P [N]	Fr2 C [N]
185	271,16	0,07	3,3	472	-	4000
180	342,65	0,05	2,6	472	-	4000

IBA72

Mn ₂ [Nm]	i	Pn ₁ [kW]	n ₂ [rpm]	Fr1 [N]	Fr2 D-S-P [N]	Fr2 C [N]
298	8,36	3,50	107,7	664	5885	2942
298	10,06	2,91	89,5	685	6260	3130
298	12,44	2,35	72,3	667	6720	3360
358	14,91	2,36	60,4	826	7137	3568
358	17,94	1,96	50,2	685	7592	3796
358	22,19	1,58	40,5	667	8150	4075
358	27,45	1,28	32,8	667	8748	4374
358	33,04	1,06	27,2	685	9306	4653
340	40,87	0,82	22,0	635	9989	4995
298	45,64	0,64	19,7	646	10000	5182
298	54,94	0,53	16,4	685	10000	5500
296	67,96	0,43	13,2	667	10000	5500

IBA73

Mn ₂ [Nm]	i	Pn ₁ [kW]	n ₂ [rpm]	Fr1 [N]	Fr2 D-S-P [N]	Fr2 C [N]
384	43,89	0,91	20,5	330	10000	5115
384	52,83	0,75	17,0	411	10000	5441
382	65,35	0,61	13,8	400	10000	5500
384	80,83	0,49	11,1	400	10000	5500
382	97,29	0,41	9,2	411	10000	5500
384	120,34	0,33	7,5	400	10000	5500
384	149,73	0,27	6,0	398	10000	5500
386	180,23	0,22	5,0	411	10000	5500
384	222,93	0,18	4,0	400	10000	5500
382	260,20	0,15	3,5	424	10000	5500
388	321,85	0,12	2,8	400	10000	5500
374	357,95	0,11	2,5	445	10000	5500
394	442,76	0,09	2,0	400	10000	5500

IB063

Mn ₂ [Nm]	i	Pn ₁ [kW]	n ₂ [rpm]	Fr1 [N]	Fr2 D-S-P [N]	Fr2 C [N]
208	5,71	3,77	157,5	270	8278	2365

IB063

Mn ₂ [Nm]	i	Pn ₁ [kW]	n ₂ [rpm]	Fr1 [N]	Fr2 D-S-P [N]	Fr2 C [N]
244	6,88	3,68	130,8	294	8651	2472
252	7,32	3,57	122,9	324	8817	2519
332	9,16	3,76	98,2	280	9099	2600
374	10,26	3,78	87,7	272	9246	2642
390	11,03	3,67	81,6	302	9432	2695
418	12,35	3,51	72,8	339	9701	2772
426	13,15	3,36	68,4	377	9913	2832
426	15,18	2,91	59,3	485	10527	3008
432	17,00	2,63	52,9	551	10989	3140
432	22,39	2,00	40,2	705	12000	3516
432	26,09	1,72	34,5	774	12000	3740
432	28,03	1,60	32,1	803	12000	3849
432	33,43	1,34	26,9	865	12000	4128
432	38,58	1,16	23,3	909	12000	4367
432	43,22	1,04	20,8	939	12000	4565
510	50,81	1,04	17,7	977	12000	4860
510	56,93	0,93	15,8	1000	12000	5076
510	69,16	0,76	13,0	1034	12000	5467
510	77,48	0,68	11,6	1050	12000	5707
510	90,33	0,59	10,0	1070	12000	6045
510	101,20	0,52	8,9	1083	12000	6308
510	111,74	0,47	8,1	1094	12000	6544
510	124,20	0,43	7,2	1103	12000	6805
510	139,15	0,38	6,5	1113	12000	7097
510	157,42	0,34	5,7	1122	12000	7425

IB083

Mn ₂ [Nm]	i	Pn ₁ [kW]	n ₂ [rpm]	Fr1 [N]	Fr2 D-S-P [N]	Fr2 C [N]
360	7,81	4,78	115,2	1619	14076	4022
432	8,62	5,19	104,4	1500	14190	4054
468	10,49	4,62	85,8	1664	15098	4314
540	11,59	4,83	77,7	1604	15267	4362
585	14,43	4,20	62,4	1789	16398	4685
610	16,60	3,81	54,2	1895	17165	4904
610	18,32	3,45	49,1	2000	17855	5102
610	22,82	2,77	39,4	2197	18000	5562
610	26,71	2,37	33,7	2314	18000	5914
610	29,50	2,14	30,5	2378	18000	6145
610	31,80	1,99	28,3	2423	18000	6325
610	34,49	1,83	26,1	2468	18000	6525
610	39,60	1,60	22,7	2500	18000	6877

IB083

Mn ₂ [Nm]	i	Pn ₁ [kW]	n ₂ [rpm]	Fr1 [N]	Fr2 D-S-P [N]	Fr2 C [N]
610	42,95	1,47	20,9	2500	18000	7092
610	45,44	1,39	19,8	2500	18000	7245
725	51,19	1,47	17,6	2500	18000	7577
725	55,52	1,35	16,2	2500	18000	7811
725	59,96	1,25	15,0	2500	18000	8038
725	63,74	1,18	14,1	2500	18000	8223
725	69,14	1,09	13,0	2500	18000	8475
725	73,14	1,03	12,3	2500	18000	8653
725	80,76	0,93	11,1	2500	18000	8975
725	92,19	0,82	9,8	2500	18000	9421
725	100,57	0,75	8,9	2500	18000	9726
725	105,29	0,71	8,6	2500	18000	9890
725	116,25	0,65	7,7	2500	18000	10253
725	126,76	0,59	7,1	2500	18000	10580
725	144,77	0,52	6,2	2500	18000	11100

IB103

Mn ₂ [Nm]	i	Pn ₁ [kW]	n ₂ [rpm]	Fr1 [N]	Fr2 D-S-P [N]	Fr2 C [N]
1010	17,27	6,06	52,1	1336	21247	6070
1010	19,06	5,50	47,2	1490	22000	6311
1010	23,70	4,42	38,0	1782	22000	6872
1080	26,51	4,22	34,0	1833	22000	7090
1155	30,55	3,92	29,5	1918	22000	7406
1225	33,07	3,84	27,2	1937	22000	7552
1225	35,87	3,54	25,1	2019	22000	7797
1225	41,12	3,09	21,9	2142	22000	8224
1225	44,61	2,85	20,2	2207	22000	8488
1225	47,28	2,69	19,0	2251	22000	8681
1450	50,24	2,99	17,9	2294	22000	8886
1450	53,02	2,84	17,0	2330	22000	9072
1450	58,50	2,57	15,4	2391	22000	9420
1450	64,89	2,32	13,9	2449	22000	9798
1450	68,58	2,19	13,1	2478	22000	10006
1450	72,76	2,07	12,4	2506	22000	10232
1450	78,92	1,90	11,4	2544	22000	10550
1535	83,66	1,90	10,8	2544	22000	10697
1535	92,31	1,72	9,8	2585	22000	11102
1535	105,44	1,51	8,5	2634	22000	11670
1535	114,80	1,39	7,8	2662	22000	12046
1535	120,42	1,32	7,5	2677	22000	12262
1535	132,87	1,20	6,8	2706	22000	12718

IB103

Mn ₂ [Nm]	i	Pn ₁ [kW]	n ₂ [rpm]	Fr1 [N]	Fr2 D-S-P [N]	Fr2 C [N]
1535	144,69	1,10	6,2	2728	22000	13125
1535	165,25	0,96	5,5	2760	22000	13783

IB123

Mn ₂ [Nm]	i	Pn ₁ [kW]	n ₂ [rpm]	Fr1 [N]	Fr2 D-S-P [N]	Fr2 C [N]
1085	7,97	14,12	113,0	2489	20762	5932
1300	9,62	14,01	93,6	2498	21113	6032
1445	10,33	14,50	87,1	2447	20861	5960
1445	12,48	12,00	72,1	2714	22821	6520
1515	13,84	11,35	65,0	2783	23470	6706
1515	15,38	10,21	58,5	2905	24658	7045
1590	18,58	8,87	48,5	3050	26410	7546
1805	20,61	9,08	43,7	3027	26253	7501
2020	22,78	9,19	39,5	3014	26094	7455
2020	25,89	8,09	34,8	3132	27801	7943
2020	27,51	7,61	32,7	3184	28638	8182
2020	30,79	6,80	29,2	3271	30000	8639
2020	31,26	6,70	28,8	3282	30000	8701
2020	34,68	6,04	25,9	3353	30000	9139
2020	40,53	5,17	22,2	3446	30000	9825
2165	44,89	5,00	20,1	3464	30000	10019
2310	49,80	4,81	18,1	3485	30000	10236
2730	54,30	5,21	16,6	3528	30000	10660
2730	59,36	4,77	15,2	3568	30000	11110
2820	62,59	4,67	14,4	3578	30000	11246
2815	69,43	4,20	13,0	3619	30000	11796
2990	74,42	4,17	12,1	3623	30000	11899
2990	80,04	3,87	11,2	3650	30000	12306
2990	89,87	3,45	10,0	3688	30000	12973
2990	99,70	3,11	9,0	3719	30000	13593
2990	106,65	2,91	8,4	3738	30000	14008
2990	119,60	2,59	7,5	3766	30000	14733
2990	129,96	2,39	6,9	3785	30000	15277
2990	144,43	2,15	6,2	3807	30000	15990
2990	160,23	1,93	5,6	3826	30000	16715
2990	180,40	1,72	5,0	3845	30000	17575

IB143

Mn ₂ [Nm]	i	Pn ₁ [kW]	n ₂ [rpm]	Fr1 [N]	Fr2 D-S-P [N]	Fr2 C [N]
2165	10,84	20,71	83,0	2214	18991	18991
2240	11,87	19,57	75,8	2315	19538	19538
2240	14,49	16,03	62,1	2620	21572	21572
2310	17,04	14,05	52,8	2789	22997	22997
2600	18,66	14,45	48,2	2756	22681	22681
2890	21,00	14,27	42,9	2771	22722	22722
3180	22,77	14,48	39,5	2754	22363	22363
3325	25,63	13,45	35,1	2843	23168	23168
3325	27,44	12,56	32,8	2919	24049	24049
3395	30,05	11,71	29,9	2992	24912	24912
3395	33,01	10,66	27,3	3082	26194	26194
3470	36,67	9,81	24,5	3157	27341	27341
3470	40,29	8,93	22,3	3233	28710	28710
3470	44,16	8,15	20,4	3300	30087	30087
3615	48,35	7,75	18,6	3334	30819	30819
4270	53,16	8,33	16,9	3395	32330	32330
4270	54,63	8,10	16,5	3411	32773	32773
4270	59,02	7,50	15,2	3455	34052	34052
4270	64,88	6,82	13,9	3504	35666	35666
4270	70,43	6,29	12,8	3544	37106	37106
4270	77,12	5,74	11,7	3583	38741	38741
4270	85,54	5,18	10,5	3625	40000	40000
4270	94,13	4,70	9,6	3659	40000	40000
4270	105,83	4,18	8,5	3697	40000	40000
4270	111,94	3,95	8,0	3714	40000	40000
4270	124,62	3,55	7,2	3743	40000	40000
4270	136,44	3,24	6,6	3766	40000	40000
4270	149,59	2,96	6,0	3786	40000	40000
4270	166,53	2,66	5,4	3808	40000	40000
4270	187,24	2,36	4,8	3830	40000	40000

IB153

Mn ₂ [Nm]	i	Pn ₁ [kW]	n ₂ [rpm]	Fr1 [N]	Fr2 D-S-P [N]	Fr2 C [N]
3250	10,49	32,11	85,8	6890	38488	38488
3250	12,64	26,65	71,2	7398	41370	41370
3615	14,01	26,75	64,2	7391	42266	42266
3615	15,40	24,34	58,4	7615	43850	43850
4335	18,56	24,22	48,5	7624	45580	45580
4695	20,56	23,67	43,8	7675	46701	46701
4845	23,86	21,05	37,7	7920	49243	49243
4915	25,19	20,23	35,7	7996	50164	50164

IB153

Mn ₂ [Nm]	i	Pn ₁ [kW]	n ₂ [rpm]	Fr1 [N]	Fr2 D-S-P [N]	Fr2 C [N]
5780	28,23	21,23	31,9	7903	50642	50642
5780	30,35	19,75	29,7	8040	52163	52163
5780	33,63	17,82	26,8	8219	54387	54387
5785	35,02	17,13	25,7	8285	55282	55282
5785	38,81	15,45	23,2	8440	57613	57613
5785	42,30	14,18	21,3	8559	59628	59628
5780	47,53	12,61	18,9	8704	62454	62454
6835	50,56	14,01	17,8	8774	63995	63995
6835	54,64	12,97	16,5	8856	65000	65000
6835	57,27	12,37	15,7	8903	65000	65000
6835	60,92	11,63	14,8	8961	65000	65000
6835	63,47	11,16	14,2	8998	65000	65000
6835	71,15	9,96	12,7	9092	65000	65000
6835	77,22	9,18	11,7	9154	65000	65000
6835	83,89	8,45	10,7	9211	65000	65000
6835	87,65	8,08	10,3	9240	65000	65000
6835	93,05	7,62	9,7	9277	65000	65000
6835	103,12	6,87	8,7	9335	65000	65000
6835	123,88	5,72	7,3	9425	65000	65000
6835	134,27	5,28	6,7	9460	65000	65000
6835	149,26	4,75	6,0	9502	65000	65000
6835	165,42	4,28	5,4	9538	65000	65000

IB163

Mn ₂ [Nm]	i	Pn ₁ [kW]	n ₂ [rpm]	Fr1 [N]	Fr2 D-S-P [N]	Fr2 C [N]
4151	8,89	48,40	101,2	6911	54659	54659
4794	10,58	47,00	85,1	6990	56595	56595
5565	11,87	48,61	75,8	7428	59722	59722
6360	12,81	51,48	70,3	7257	59584	59584
6940	14,08	51,09	63,9	7281	60524	60524
7230	15,52	48,29	58,0	7448	62338	62338
7160	16,39	45,30	54,9	7626	63977	63977
7520	18,02	43,27	50,0	7746	65672	65000
7735	19,96	40,18	45,1	7929	68031	65000
7515	21,94	35,51	41,0	8206	71371	65000
7590	24,17	32,55	37,2	8383	74121	65000
8025	26,58	31,30	33,9	8457	75990	65000
7375	28,80	26,55	31,2	8740	80000	65000
8315	30,92	27,88	29,1	8661	80000	65000
8600	34,25	26,03	26,3	8770	80000	65000
8890	37,66	24,47	23,9	8863	80000	65000

IB163

Mn_2 [Nm]	i	Pn_1 [kW]	n_2 [rpm]	Fr1 [N]	Fr2 D-S-P [N]	Fr2 C [N]
9180	40,65	23,41	22,1	8926	80000	65000
8675	45,09	19,95	20,0	9132	80000	65000
11110	51,00	22,58	17,6	9182	80000	65000
11110	53,63	21,48	16,8	9238	80000	65000
11110	58,97	19,53	15,3	9336	80000	65000
11110	69,78	16,51	12,9	9488	80000	65000
11110	76,72	15,01	11,7	9563	80000	65000
11110	87,54	13,16	10,3	9656	80000	65000
11110	96,25	11,97	9,3	9716	80000	65000
11110	103,93	11,08	8,7	9761	80000	65000
11110	114,27	10,08	7,9	9811	80000	65000
11110	126,29	9,12	7,1	9859	80000	65000
11110	138,85	8,30	6,5	9901	80000	65000
11110	154,83	7,44	5,8	9944	80000	65000

IBA42

Mn ₂ [Nm]	i	Pn ₁ [kW]	n ₂ [rpm]	Fr1 [N]	Fr2 D-S-P [N]	Fr2 C [N]
77	7,62	0,77	91,9	373	-	2286
77	10,62	0,55	65,9	355	-	2554
77	12,95	0,45	54,1	406	-	2728
77	14,46	0,40	48,4	443	-	2830
102	16,47	0,47	42,5	579	-	2956
103	22,97	0,34	30,5	355	-	3303
102	28,00	0,28	25,0	406	-	3528
102	31,27	0,25	22,4	443	-	3660
103	33,78	0,23	20,7	458	-	3756
102	47,12	0,16	14,9	355	-	4000
102	57,43	0,14	12,2	406	-	4000
92	64,13	0,11	10,9	406	-	4000
95	78,17	0,09	9,0	406	-	4000

IBA52

Mn ₂ [Nm]	i	Pn ₁ [kW]	n ₂ [rpm]	Fr1 [N]	Fr2 D-S-P [N]	Fr2 C [N]
137	7,91	1,32	88,5	373	-	2480
137	9,46	1,10	74,0	414	-	2633
136	11,57	0,89	60,5	405	-	2816
137	14,63	0,71	47,9	392	-	3044
171	17,11	0,76	40,9	529	-	3208
171	20,46	0,64	34,2	414	-	3405
170	25,03	0,52	28,0	405	-	3641
172	31,63	0,41	22,1	392	-	3936
171	35,10	0,37	19,9	446	-	4000
172	41,97	0,31	16,7	414	-	4000
188	51,34	0,28	13,6	445	-	4000
172	64,87	0,20	10,8	356	-	4000
171	79,07	0,16	8,8	406	-	4000

IBA53

Mn ₂ [Nm]	i	Pn ₁ [kW]	n ₂ [rpm]	Fr1 [N]	Fr2 D-S-P [N]	Fr2 C [N]
189	73,70	0,21	9,5	472	-	4000
186	93,33	0,16	7,5	472	-	4000
187	111,61	0,13	6,3	472	-	4000
186	136,53	0,11	5,1	472	-	4000
190	172,53	0,09	4,1	472	-	4000
186	197,11	0,08	3,5	472	-	4000
183	249,08	0,06	2,8	472	-	4000

IBA53

Mn ₂ [Nm]	i	Pn ₁ [kW]	n ₂ [rpm]	Fr1 [N]	Fr2 D-S-P [N]	Fr2 C [N]
185	271,16	0,05	2,6	472	-	4000
180	342,65	0,04	2,0	472	-	4000

IBA72

Mn ₂ [Nm]	i	Pn ₁ [kW]	n ₂ [rpm]	Fr1 [N]	Fr2 D-S-P [N]	Fr2 C [N]
298	8,36	2,71	83,8	664	6399	3200
298	10,06	2,25	69,6	685	6807	3404
298	12,44	1,82	56,3	667	7307	3654
358	14,91	1,83	47,0	826	7761	3880
358	17,94	1,52	39,0	685	8255	4128
358	22,19	1,23	31,5	667	8862	4431
358	27,45	0,99	25,5	667	9512	4756
358	33,04	0,82	21,2	685	10000	5059
340	40,87	0,63	17,1	635	10000	5431
298	45,64	0,50	15,3	646	10000	5500
298	54,94	0,41	12,7	685	10000	5500
296	67,96	0,33	10,3	667	10000	5500

IBA73

Mn ₂ [Nm]	i	Pn ₁ [kW]	n ₂ [rpm]	Fr1 [N]	Fr2 D-S-P [N]	Fr2 C [N]
384	43,89	0,70	15,9	330	10000	5500
384	52,83	0,58	13,2	411	10000	5500
382	65,35	0,47	10,7	400	10000	5500
384	80,83	0,38	8,7	400	10000	5500
382	97,29	0,32	7,2	411	10000	5500
384	120,34	0,26	5,8	400	10000	5500
384	149,73	0,21	4,7	398	10000	5500
386	180,23	0,17	3,9	411	10000	5500
384	222,93	0,14	3,1	400	10000	5500
382	260,20	0,12	2,7	424	10000	5500
388	321,85	0,10	2,2	400	10000	5500
374	357,95	0,08	2,0	445	10000	5500
394	442,76	0,07	1,6	400	10000	5500

IB063

Mn ₂ [Nm]	i	Pn ₁ [kW]	n ₂ [rpm]	Fr1 [N]	Fr2 D-S-P [N]	Fr2 C [N]
208	5,71	2,92	122,5	259	9097	2599

IB063

Mn ₂ [Nm]	i	Pn ₁ [kW]	n ₂ [rpm]	Fr1 [N]	Fr2 D-S-P [N]	Fr2 C [N]
244	6,88	2,85	101,8	283	9519	2720
252	7,32	2,76	95,6	313	9703	2772
332	9,16	2,91	76,4	269	10049	2871
374	10,26	2,92	68,2	261	10229	2923
390	11,03	2,84	63,5	292	10438	2982
418	12,35	2,71	56,7	329	10744	3070
426	13,15	2,60	53,2	367	10978	3137
426	15,18	2,25	46,1	477	11646	3327
432	17,00	2,04	41,2	543	12000	3472
432	22,39	1,55	31,3	699	12000	3880
432	26,09	1,33	26,8	769	12000	4124
432	28,03	1,24	25,0	798	12000	4242
432	33,43	1,04	20,9	861	12000	4545
432	38,58	0,90	18,1	905	12000	4805
432	43,22	0,80	16,2	936	12000	5020
510	50,81	0,81	13,8	974	12000	5340
510	56,93	0,72	12,3	997	12000	5576
510	69,16	0,59	10,1	1032	12000	6000
510	77,48	0,53	9,0	1049	12000	6261
510	90,33	0,45	7,8	1069	12000	6629
510	101,20	0,40	6,9	1082	12000	6914
510	111,74	0,37	6,3	1092	12000	7171
510	124,20	0,33	5,6	1102	12000	7454
510	139,15	0,29	5,0	1112	12000	7771
510	157,42	0,26	4,5	1121	12000	8000

IB083

Mn ₂ [Nm]	i	Pn ₁ [kW]	n ₂ [rpm]	Fr1 [N]	Fr2 D-S-P [N]	Fr2 C [N]
360	7,81	3,70	89,6	1603	15452	4415
432	8,62	4,02	81,2	1482	15607	4459
468	10,49	3,58	66,7	1648	16610	4746
540	11,59	3,74	60,4	1588	16825	4807
585	14,43	3,25	48,5	1775	18000	5163
610	16,60	2,95	42,2	1882	18000	5405
610	18,32	2,67	38,2	1988	18000	5620
610	22,82	2,15	30,7	2187	18000	6120
610	26,71	1,83	26,2	2306	18000	6502
610	29,50	1,66	23,7	2371	18000	6753
610	31,80	1,54	22,0	2417	18000	6949
610	34,49	1,42	20,3	2462	18000	7166
610	39,60	1,24	17,7	2500	18000	7549

IB083

Mn ₂ [Nm]	i	Pn ₁ [kW]	n ₂ [rpm]	Fr1 [N]	Fr2 D-S-P [N]	Fr2 C [N]
610	42,95	1,14	16,3	2500	18000	7783
610	45,44	1,08	15,4	2500	18000	7948
725	51,19	1,14	13,7	2500	18000	8309
725	55,52	1,05	12,6	2500	18000	8563
725	59,96	0,97	11,7	2500	18000	8810
725	63,74	0,91	11,0	2500	18000	9011
725	69,14	0,84	10,1	2500	18000	9284
725	73,14	0,80	9,6	2500	18000	9478
725	80,76	0,72	8,7	2500	18000	9828
725	92,19	0,63	7,6	2500	18000	10313
725	100,57	0,58	7,0	2500	18000	10644
725	105,29	0,55	6,7	2500	18000	10822
725	116,25	0,50	6,0	2500	18000	11216
725	126,76	0,46	5,5	2500	18000	11571
725	144,77	0,40	4,8	2500	18000	12000

IB103

Mn ₂ [Nm]	i	Pn ₁ [kW]	n ₂ [rpm]	Fr1 [N]	Fr2 D-S-P [N]	Fr2 C [N]
1010	17,27	4,69	40,5	1316	22000	6685
1010	19,06	4,25	36,7	1472	22000	6946
1010	23,70	3,42	29,5	1768	22000	7556
1080	26,51	3,27	26,4	1819	22000	7800
1155	30,55	3,03	22,9	1905	22000	8149
1225	33,07	2,97	21,2	1925	22000	8314
1225	35,87	2,74	19,5	2007	22000	8581
1225	41,12	2,39	17,0	2132	22000	9045
1225	44,61	2,20	15,7	2198	22000	9331
1225	47,28	2,08	14,8	2242	22000	9541
1450	50,24	2,32	13,9	2286	22000	9764
1450	53,02	2,19	13,2	2322	22000	9966
1450	58,50	1,99	12,0	2384	22000	10344
1450	64,89	1,79	10,8	2443	22000	10755
1450	68,58	1,70	10,2	2472	22000	10980
1450	72,76	1,60	9,6	2501	22000	11226
1450	78,92	1,47	8,9	2538	22000	11572
1535	83,66	1,47	8,4	2539	22000	11738
1535	92,31	1,33	7,6	2580	22000	12177
1535	105,44	1,17	6,6	2630	22000	12794
1535	114,80	1,07	6,1	2659	22000	13203
1535	120,42	1,02	5,8	2674	22000	13438
1535	132,87	0,93	5,3	2702	22000	13933

IB103

Mn ₂ [Nm]	i	Pn ₁ [kW]	n ₂ [rpm]	Fr1 [N]	Fr2 D-S-P [N]	Fr2 C [N]
1535	144,69	0,85	4,8	2725	22000	14376
1535	165,25	0,75	4,2	2757	22000	15000

IB123

Mn ₂ [Nm]	i	Pn ₁ [kW]	n ₂ [rpm]	Fr1 [N]	Fr2 D-S-P [N]	Fr2 C [N]
1085	7,97	10,93	87,9	2471	23098	6599
1300	9,62	10,84	72,8	2480	23587	6739
1445	10,33	11,22	67,7	2428	23384	6681
1445	12,48	9,29	56,1	2699	25514	7290
1515	13,84	8,78	50,6	2768	26255	7501
1515	15,38	7,90	45,5	2892	27546	7870
1590	18,58	6,87	37,7	3039	29486	8425
1805	20,61	7,03	34,0	3015	29423	8407
2020	22,78	7,11	30,7	3002	29358	8388
2020	25,89	6,26	27,0	3122	30000	8918
2020	27,51	5,89	25,4	3174	30000	9178
2020	30,79	5,26	22,7	3262	30000	9674
2020	31,26	5,18	22,4	3273	30000	9742
2020	34,68	4,67	20,2	3345	30000	10217
2020	40,53	4,00	17,3	3440	30000	10963
2165	44,89	3,87	15,6	3458	30000	11193
2310	49,80	3,72	14,1	3479	30000	11450
2730	54,30	4,03	12,9	3522	30000	11911
2730	59,36	3,69	11,8	3563	30000	12399
2820	62,59	3,62	11,2	3573	30000	12557
2815	69,43	3,25	10,1	3615	30000	13155
2990	74,42	3,22	9,4	3619	30000	13287
2990	80,04	3,00	8,8	3646	30000	13729
2990	89,87	2,67	7,8	3685	30000	14454
2990	99,70	2,41	7,0	3716	30000	15128
2990	106,65	2,25	6,6	3734	30000	15579
2990	119,60	2,01	5,8	3763	30000	16367
2990	129,96	1,85	5,4	3782	30000	16958
2990	144,43	1,66	4,8	3804	30000	17732
2990	160,23	1,50	4,4	3824	30000	18520
2990	180,40	1,33	3,9	3843	30000	19455

IB143

Mn ₂ [Nm]	i	Pn ₁ [kW]	n ₂ [rpm]	Fr1 [N]	Fr2 D-S-P [N]	Fr2 C [N]
2165	10,84	16,03	64,6	2193	21383	21383
2240	11,87	15,15	59,0	2294	22002	22002
2240	14,49	12,41	48,3	2603	24212	24212
2310	17,04	10,88	41,1	2775	25785	25785
2600	18,66	11,18	37,5	2741	25542	25542
2890	21,00	11,04	33,3	2757	25686	25686
3180	22,77	11,20	30,7	2739	25396	25396
3325	25,63	10,41	27,3	2829	26320	26320
3325	27,44	9,72	25,5	2906	27277	27277
3395	30,05	9,07	23,3	2980	28240	28240
3395	33,01	8,25	21,2	3071	29633	29633
3470	36,67	7,59	19,1	3147	30904	30904
3470	40,29	6,91	17,4	3223	32391	32391
3470	44,16	6,30	15,8	3292	33887	33887
3615	48,35	6,00	14,5	3326	34732	34732
4270	53,16	6,45	13,2	3387	36374	36374
4270	54,63	6,27	12,8	3404	36856	36856
4270	59,02	5,81	11,9	3448	38246	38246
4270	64,88	5,28	10,8	3499	39999	39999
4270	70,43	4,86	9,9	3538	40000	40000
4270	77,12	4,44	9,1	3578	40000	40000
4270	85,54	4,01	8,2	3620	40000	40000
4270	94,13	3,64	7,4	3655	40000	40000
4270	105,83	3,24	6,6	3693	40000	40000
4270	111,94	3,06	6,2	3710	40000	40000
4270	124,62	2,75	5,6	3740	40000	40000
4270	136,44	2,51	5,1	3763	40000	40000
4270	149,59	2,29	4,7	3784	40000	40000
4270	166,53	2,06	4,2	3806	40000	40000
4270	187,24	1,83	3,7	3828	40000	40000

IB153

Mn ₂ [Nm]	i	Pn ₁ [kW]	n ₂ [rpm]	Fr1 [N]	Fr2 D-S-P [N]	Fr2 C [N]
3250	10,49	24,85	66,7	6854	42333	42333
3250	12,64	20,63	55,4	7368	45464	45464
3615	14,01	20,70	50,0	7362	46495	46495
3615	15,40	18,84	45,5	7588	48216	48216
4335	18,56	18,75	37,7	7598	50211	50211
4695	20,56	18,32	34,0	7649	51486	51486
4845	23,86	16,29	29,3	7897	54271	54271
4915	25,19	15,66	27,8	7974	55283	55283

IB153

Mn ₂ [Nm]	i	Pn ₁ [kW]	n ₂ [rpm]	Fr1 [N]	Fr2 D-S-P [N]	Fr2 C [N]
5780	28,23	16,43	24,8	7879	55940	55940
5780	30,35	15,28	23,1	8018	57593	57593
5780	33,63	13,79	20,8	8200	60009	60009
5785	35,02	13,26	20,0	8266	60981	60981
5785	38,81	11,96	18,0	8423	63514	63514
5785	42,30	10,97	16,6	8543	65000	65000
5780	47,53	9,76	14,7	8690	65000	65000
6835	50,56	10,85	13,8	8761	65000	65000
6835	54,64	10,04	12,8	8844	65000	65000
6835	57,27	9,58	12,2	8891	65000	65000
6835	60,92	9,00	11,5	8950	65000	65000
6835	63,47	8,64	11,0	8987	65000	65000
6835	71,15	7,71	9,8	9083	65000	65000
6835	77,22	7,10	9,1	9145	65000	65000
6835	83,89	6,54	8,3	9203	65000	65000
6835	87,65	6,26	8,0	9232	65000	65000
6835	93,05	5,89	7,5	9269	65000	65000
6835	103,12	5,32	6,8	9329	65000	65000
6835	123,88	4,43	5,7	9420	65000	65000
6835	134,27	4,08	5,2	9455	65000	65000
6835	149,26	3,67	4,7	9497	65000	65000
6835	165,42	3,32	4,2	9534	65000	65000

IB163

Mn ₂ [Nm]	i	Pn ₁ [kW]	n ₂ [rpm]	Fr1 [N]	Fr2 D-S-P [N]	Fr2 C [N]
4915	8,89	44,35	78,7	6870	60316	60316
5715	10,58	43,36	66,2	6950	62569	62569
5565	11,87	37,62	59,0	7393	65940	65000
6360	12,81	39,84	54,6	7221	65940	65000
6940	14,08	39,54	49,7	7245	67071	65000
7230	15,52	37,38	45,1	7413	69097	65000
7160	16,39	35,06	42,7	7594	70864	65000
7520	18,02	33,49	38,9	7715	72773	65000
7735	19,96	31,10	35,1	7901	75377	65000
7515	21,94	27,48	31,9	8181	78965	65000
7590	24,17	25,19	29,0	8360	80000	65000
8025	26,58	24,23	26,3	8435	80000	65000
7375	28,80	20,55	24,3	8721	80000	65000
8315	30,92	21,58	22,6	8641	80000	65000
8600	34,25	20,15	20,4	8752	80000	65000
8890	37,66	18,94	18,6	8846	80000	65000

IB163

Mn ₂ [Nm]	i	Pn ₁ [kW]	n ₂ [rpm]	Fr1 [N]	Fr2 D-S-P [N]	Fr2 C [N]
9180	40,65	18,12	17,2	8909	80000	65000
8675	45,09	15,44	15,5	9118	80000	65000
11110	51,00	17,48	13,7	9169	80000	65000
11110	53,63	16,62	13,1	9225	80000	65000
11110	58,97	15,12	11,9	9324	80000	65000
11110	69,78	12,78	10,0	9478	80000	65000
11110	76,72	11,62	9,1	9554	80000	65000
11110	87,54	10,18	8,0	9648	80000	65000
11110	96,25	9,26	7,3	9709	80000	65000
11110	103,93	8,58	6,7	9754	80000	65000
11110	114,27	7,80	6,1	9805	80000	65000
11110	126,29	7,06	5,5	9854	80000	65000
11110	138,85	6,42	5,0	9896	80000	65000
11110	154,83	5,76	4,5	9939	80000	65000

IBA42

Mn ₂ [Nm]	i	Pn ₁ [kW]	n ₂ [rpm]	Fr1 [N]	Fr2 D-S-P [N]	Fr2 C [N]
77	7,62	0,55	65,7	373	-	2557
77	10,62	0,39	47,1	355	-	2857
77	12,95	0,32	38,6	406	-	3052
77	14,46	0,29	34,6	443	-	3166
102	16,47	0,33	30,4	579	-	3307
103	22,97	0,24	21,8	355	-	3695
102	28,00	0,20	17,9	406	-	3946
102	31,27	0,18	16,0	443	-	4000
103	33,78	0,16	14,8	458	-	4000
102	47,12	0,12	10,6	355	-	4000
102	57,43	0,10	8,7	406	-	4000
92	64,13	0,08	7,8	406	-	4000
95	78,17	0,07	6,4	406	-	4000

IBA52

Mn ₂ [Nm]	i	Pn ₁ [kW]	n ₂ [rpm]	Fr1 [N]	Fr2 D-S-P [N]	Fr2 C [N]
137	7,91	0,94	63,2	373	-	2775
137	9,46	0,78	52,9	414	-	2945
136	11,57	0,63	43,2	405	-	3150
137	14,63	0,51	34,2	392	-	3405
171	17,11	0,54	29,2	529	-	3588
171	20,46	0,45	24,4	414	-	3809
170	25,03	0,37	20,0	405	-	4000
172	31,63	0,29	15,8	392	-	4000
171	35,10	0,26	14,2	446	-	4000
172	41,97	0,22	11,9	414	-	4000
188	51,34	0,20	9,7	445	-	4000
172	64,87	0,14	7,7	356	-	4000
171	79,07	0,12	6,3	406	-	4000

IBA53

Mn ₂ [Nm]	i	Pn ₁ [kW]	n ₂ [rpm]	Fr1 [N]	Fr2 D-S-P [N]	Fr2 C [N]
189	73,70	0,15	6,8	472	-	4000
186	93,33	0,11	5,4	472	-	4000
187	111,61	0,10	4,5	472	-	4000
186	136,53	0,08	3,7	472	-	4000
190	172,53	0,06	2,9	472	-	4000
186	197,11	0,05	2,5	472	-	4000
183	249,08	0,04	2,0	472	-	4000

IBA53

Mn ₂ [Nm]	i	Pn ₁ [kW]	n ₂ [rpm]	Fr1 [N]	Fr2 D-S-P [N]	Fr2 C [N]
185	271,16	0,04	1,8	472	-	4000
180	342,65	0,03	1,5	472	-	4000

IBA72

Mn ₂ [Nm]	i	Pn ₁ [kW]	n ₂ [rpm]	Fr1 [N]	Fr2 D-S-P [N]	Fr2 C [N]
298	8,36	1,93	59,8	664	7159	3579
298	10,06	1,60	49,7	685	7615	3808
298	12,44	1,29	40,2	667	8174	4087
358	14,91	1,30	33,5	826	8682	4341
358	17,94	1,08	27,9	685	9235	4618
358	22,19	0,87	22,5	667	9913	4957
358	27,45	0,70	18,2	667	10000	5321
358	33,04	0,59	15,1	685	10000	5500
340	40,87	0,45	12,2	635	10000	5500
298	45,64	0,35	10,9	646	10000	5500
298	54,94	0,29	9,1	685	10000	5500
296	67,96	0,24	7,4	667	10000	5500

IBA73

Mn ₂ [Nm]	i	Pn ₁ [kW]	n ₂ [rpm]	Fr1 [N]	Fr2 D-S-P [N]	Fr2 C [N]
384	43,89	0,50	11,4	330	10000	5500
384	52,83	0,41	9,5	411	10000	5500
382	65,35	0,33	7,7	400	10000	5500
384	80,83	0,27	6,2	400	10000	5500
382	97,29	0,22	5,1	411	10000	5500
384	120,34	0,18	4,2	400	10000	5500
384	149,73	0,15	3,3	398	10000	5500
386	180,23	0,12	2,8	411	10000	5500
384	222,93	0,10	2,2	400	10000	5500
382	260,20	0,08	1,9	424	10000	5500
388	321,85	0,07	1,6	400	10000	5500
374	357,95	0,06	1,4	445	10000	5500
394	442,76	0,05	1,1	400	10000	5500

IB063

Mn ₂ [Nm]	i	Pn ₁ [kW]	n ₂ [rpm]	Fr1 [N]	Fr2 D-S-P [N]	Fr2 C [N]
208	5,71	2,08	87,5	248	10312	2946

IB063

Mn ₂ [Nm]	i	Pn ₁ [kW]	n ₂ [rpm]	Fr1 [N]	Fr2 D-S-P [N]	Fr2 C [N]
244	6,88	2,02	72,7	273	10809	3088
252	7,32	1,96	68,3	303	11020	3149
332	9,16	2,07	54,6	258	11462	3275
374	10,26	2,08	48,7	250	11694	3341
390	11,03	2,02	45,3	281	11938	3411
418	12,35	1,93	40,5	319	12000	3514
426	13,15	1,85	38,0	358	12000	3590
426	15,18	1,60	33,0	469	12000	3804
432	17,00	1,45	29,4	535	12000	3966
432	22,39	1,10	22,3	693	12000	4423
432	26,09	0,94	19,2	764	12000	4695
432	28,03	0,88	17,8	793	12000	4827
432	33,43	0,74	15,0	858	12000	5166
432	38,58	0,64	13,0	902	12000	5456
432	43,22	0,57	11,6	933	12000	5696
510	50,81	0,57	9,8	972	12000	6054
510	56,93	0,51	8,8	995	12000	6317
510	69,16	0,42	7,2	1030	12000	6792
510	77,48	0,38	6,5	1047	12000	7083
510	90,33	0,32	5,5	1068	12000	7494
510	101,20	0,29	4,9	1081	12000	7812
510	111,74	0,26	4,5	1091	12000	8000
510	124,20	0,23	4,0	1101	12000	8000
510	139,15	0,21	3,6	1111	12000	8000
510	157,42	0,18	3,2	1120	12000	8000

IB083

Mn ₂ [Nm]	i	Pn ₁ [kW]	n ₂ [rpm]	Fr1 [N]	Fr2 D-S-P [N]	Fr2 C [N]
360	7,81	2,63	64,0	1587	17494	4998
432	8,62	2,86	58,0	1464	17713	5061
468	10,49	2,54	47,6	1633	18000	5387
540	11,59	2,66	43,1	1571	18000	5469
585	14,43	2,31	34,6	1761	18000	5875
610	16,60	2,10	30,1	1869	18000	6150
610	18,32	1,90	27,3	1976	18000	6390
610	22,82	1,52	21,9	2177	18000	6949
610	26,71	1,30	18,7	2297	18000	7376
610	29,50	1,18	16,9	2364	18000	7657
610	31,80	1,09	15,7	2410	18000	7875
610	34,49	1,01	14,5	2456	18000	8118
610	39,60	0,88	12,6	2500	18000	8546

IB083

Mn ₂ [Nm]	i	Pn ₁ [kW]	n ₂ [rpm]	Fr1 [N]	Fr2 D-S-P [N]	Fr2 C [N]
610	42,95	0,81	11,6	2500	18000	8807
610	45,44	0,77	11,0	2500	18000	8992
725	51,19	0,81	9,8	2500	18000	9395
725	55,52	0,74	9,0	2500	18000	9679
725	59,96	0,69	8,3	2500	18000	9955
725	63,74	0,65	7,8	2500	18000	10179
725	69,14	0,60	7,2	2500	18000	10485
725	73,14	0,57	6,8	2500	18000	10701
725	80,76	0,51	6,2	2500	18000	11092
725	92,19	0,45	5,4	2500	18000	11634
725	100,57	0,41	5,0	2500	18000	12000
725	105,29	0,39	4,8	2500	18000	12000
725	116,25	0,36	4,3	2500	18000	12000
725	126,76	0,33	3,9	2500	18000	12000
725	144,77	0,29	3,5	2500	18000	12000

IB103

Mn ₂ [Nm]	i	Pn ₁ [kW]	n ₂ [rpm]	Fr1 [N]	Fr2 D-S-P [N]	Fr2 C [N]
1010	17,27	3,34	28,9	1296	22000	7600
1010	19,06	3,02	26,2	1454	22000	7891
1010	23,70	2,43	21,1	1753	22000	8572
1080	26,51	2,32	18,9	1805	22000	8854
1155	30,55	2,16	16,4	1893	22000	9254
1225	33,07	2,11	15,1	1912	22000	9447
1225	35,87	1,95	13,9	1996	22000	9745
1225	41,12	1,70	12,2	2122	22000	10264
1225	44,61	1,57	11,2	2189	22000	10584
1225	47,28	1,48	10,6	2234	22000	10819
1450	50,24	1,65	9,9	2278	22000	11068
1450	53,02	1,56	9,4	2315	22000	11293
1450	58,50	1,41	8,6	2377	22000	11715
1450	64,89	1,27	7,7	2436	22000	12175
1450	68,58	1,21	7,3	2466	22000	12427
1450	72,76	1,14	6,9	2495	22000	12701
1450	78,92	1,05	6,3	2533	22000	13088
1535	83,66	1,05	6,0	2534	22000	13283
1535	92,31	0,95	5,4	2576	22000	13773
1535	105,44	0,83	4,7	2626	22000	14463
1535	114,80	0,76	4,4	2655	22000	14920
1535	120,42	0,73	4,2	2670	22000	15000
1535	132,87	0,66	3,8	2699	22000	15000

IB103

Mn ₂ [Nm]	i	Pn ₁ [kW]	n ₂ [rpm]	Fr1 [N]	Fr2 D-S-P [N]	Fr2 C [N]
1535	144,69	0,61	3,5	2722	22000	15000
1535	165,25	0,53	3,0	2754	22000	15000

IB123

Mn ₂ [Nm]	i	Pn ₁ [kW]	n ₂ [rpm]	Fr1 [N]	Fr2 D-S-P [N]	Fr2 C [N]
1085	7,97	7,77	62,8	2453	26584	7595
1300	9,62	7,71	52,0	2462	27285	7796
1445	10,33	7,97	48,4	2410	27163	7761
1445	12,48	6,60	40,1	2683	29542	8441
1515	13,84	6,24	36,1	2754	30000	8692
1515	15,38	5,62	32,5	2878	30000	9104
1590	18,58	4,88	26,9	3027	30000	9738
1805	20,61	5,00	24,3	3004	30000	9762
2020	22,78	5,06	21,9	2990	30000	9786
2020	25,89	4,45	19,3	3112	30000	10378
2020	27,51	4,19	18,2	3164	30000	10668
2020	30,79	3,74	16,2	3253	30000	11223
2020	31,26	3,68	16,0	3265	30000	11299
2020	34,68	3,32	14,4	3337	30000	11830
2020	40,53	2,84	12,3	3433	30000	12663
2165	44,89	2,75	11,1	3452	30000	12950
2310	49,80	2,65	10,0	3473	30000	13267
2730	54,30	2,87	9,2	3517	30000	13782
2730	59,36	2,62	8,4	3558	30000	14327
2820	62,59	2,57	8,0	3568	30000	14518
2815	69,43	2,31	7,2	3610	30000	15187
2990	74,42	2,29	6,7	3614	30000	15364
2990	80,04	2,13	6,2	3642	30000	15858
2990	89,87	1,90	5,6	3681	30000	16668
2990	99,70	1,71	5,0	3712	30000	17421
2990	106,65	1,60	4,7	3731	30000	17925
2990	119,60	1,43	4,2	3761	30000	18805
2990	129,96	1,31	3,9	3780	30000	19466
2990	144,43	1,18	3,5	3802	30000	20000
2990	160,23	1,06	3,1	3822	30000	20000
2990	180,40	0,95	2,8	3842	30000	20000

IB143

Mn ₂ [Nm]	i	Pn ₁ [kW]	n ₂ [rpm]	Fr1 [N]	Fr2 D-S-P [N]	Fr2 C [N]
2165	10,84	11,39	46,1	2171	24968	24968
2240	11,87	10,76	42,1	2274	25696	25696
2240	14,49	8,82	34,5	2587	28165	28165
2310	17,04	7,73	29,3	2760	29959	29959
2600	18,66	7,95	26,8	2726	29831	29831
2890	21,00	7,85	23,8	2742	30135	30135
3180	22,77	7,96	22,0	2724	29954	29954
3325	25,63	7,40	19,5	2815	31059	31059
3325	27,44	6,91	18,2	2894	32128	32128
3395	30,05	6,44	16,6	2968	33240	33240
3395	33,01	5,87	15,2	3060	34796	34796
3470	36,67	5,40	13,6	3137	36252	36252
3470	40,29	4,91	12,4	3214	37914	37914
3470	44,16	4,48	11,3	3283	39586	39586
3615	48,35	4,26	10,3	3318	40000	40000
4270	53,16	4,58	9,4	3380	40000	40000
4270	54,63	4,46	9,2	3397	40000	40000
4270	59,02	4,13	8,5	3442	40000	40000
4270	64,88	3,75	7,7	3493	40000	40000
4270	70,43	3,46	7,1	3533	40000	40000
4270	77,12	3,16	6,5	3573	40000	40000
4270	85,54	2,85	5,8	3616	40000	40000
4270	94,13	2,59	5,3	3651	40000	40000
4270	105,83	2,30	4,7	3690	40000	40000
4270	111,94	2,18	4,5	3707	40000	40000
4270	124,62	1,95	4,0	3737	40000	40000
4270	136,44	1,78	3,7	3760	40000	40000
4270	149,59	1,63	3,3	3781	40000	40000
4270	166,53	1,46	3,0	3804	40000	40000
4270	187,24	1,30	2,7	3826	40000	40000

IB153

Mn ₂ [Nm]	i	Pn ₁ [kW]	n ₂ [rpm]	Fr1 [N]	Fr2 D-S-P [N]	Fr2 C [N]
3250	10,49	17,67	47,6	6819	48046	48046
3250	12,64	14,66	39,5	7339	51544	51544
3615	14,01	14,72	35,7	7332	52779	52779
3615	15,40	13,39	32,5	7561	54701	54701
4335	18,56	13,32	26,9	7571	57095	57095
4695	20,56	13,02	24,3	7623	58602	58602
4845	23,86	11,58	21,0	7874	61748	61748
4915	25,19	11,13	19,9	7951	62895	62895

IB153

Mn ₂ [Nm]	i	Pn ₁ [kW]	n ₂ [rpm]	Fr1 [N]	Fr2 D-S-P [N]	Fr2 C [N]
5780	28,23	11,68	17,7	7856	63827	63827
5780	30,35	10,86	16,5	7997	65000	65000
5780	33,63	9,80	14,9	8180	65000	65000
5785	35,02	9,42	14,3	8247	65000	65000
5785	38,81	8,50	12,9	8406	65000	65000
5785	42,30	7,80	11,8	8527	65000	65000
5780	47,53	6,94	10,5	8676	65000	65000
6835	50,56	7,71	9,9	8748	65000	65000
6835	54,64	7,13	9,2	8832	65000	65000
6835	57,27	6,81	8,7	8880	65000	65000
6835	60,92	6,40	8,2	8939	65000	65000
6835	63,47	6,14	7,9	8977	65000	65000
6835	71,15	5,48	7,0	9074	65000	65000
6835	77,22	5,05	6,5	9137	65000	65000
6835	83,89	4,65	6,0	9195	65000	65000
6835	87,65	4,45	5,7	9225	65000	65000
6835	93,05	4,19	5,4	9262	65000	65000
6835	103,12	3,78	4,8	9322	65000	65000
6835	123,88	3,15	4,0	9415	65000	65000
6835	134,27	2,90	3,7	9450	65000	65000
6835	149,26	2,61	3,4	9493	65000	65000
6835	165,42	2,36	3,0	9530	65000	65000

IB163

Mn ₂ [Nm]	i	Pn ₁ [kW]	n ₂ [rpm]	Fr1 [N]	Fr2 D-S-P [N]	Fr2 C [N]
4915	8,89	31,53	56,2	6830	68733	65000
5715	10,58	30,82	47,3	6910	71467	65000
5565	11,87	26,74	42,1	7359	75194	65000
6360	12,81	28,32	39,0	7184	75410	65000
6940	14,08	28,10	35,5	7209	76831	65000
7230	15,52	26,57	32,2	7379	79173	65000
7160	16,39	24,92	30,5	7562	80000	65000
7520	18,02	23,81	27,8	7685	80000	65000
7735	19,96	22,11	25,1	7872	80000	65000
7515	21,94	19,53	22,8	8156	80000	65000
7590	24,17	17,91	20,7	8337	80000	65000
8025	26,58	17,22	18,8	8413	80000	65000
7375	28,80	14,60	17,4	8702	80000	65000
8315	30,92	15,34	16,2	8622	80000	65000
8600	34,25	14,32	14,6	8733	80000	65000
8890	37,66	13,46	13,3	8828	80000	65000

IB163

Mn_2 [Nm]	i	Pn_1 [kW]	n2 [rpm]	Fr1 [N]	Fr2 D-S-P [N]	Fr2 C [N]
9180	40,65	12,88	12,3	8893	80000	65000
8675	45,09	10,97	11,1	9104	80000	65000
11110	51,00	12,42	9,8	9155	80000	65000
11110	53,63	11,82	9,3	9212	80000	65000
11110	58,97	10,75	8,5	9312	80000	65000
11110	69,78	9,08	7,2	9468	80000	65000
11110	76,72	8,26	6,5	9545	80000	65000
11110	87,54	7,24	5,7	9641	80000	65000
11110	96,25	6,58	5,2	9702	80000	65000
11110	103,93	6,10	4,8	9747	80000	65000
11110	114,27	5,54	4,4	9799	80000	65000
11110	126,29	5,02	4,0	9848	80000	65000
11110	138,85	4,56	3,6	9891	80000	65000
11110	154,83	4,09	3,2	9935	80000	65000

All supplies effected by Motovario are governed exclusively by the general terms of sale that you can find on our website:

<http://www.motovario.com/eng/corporate/sales-conditions>

