

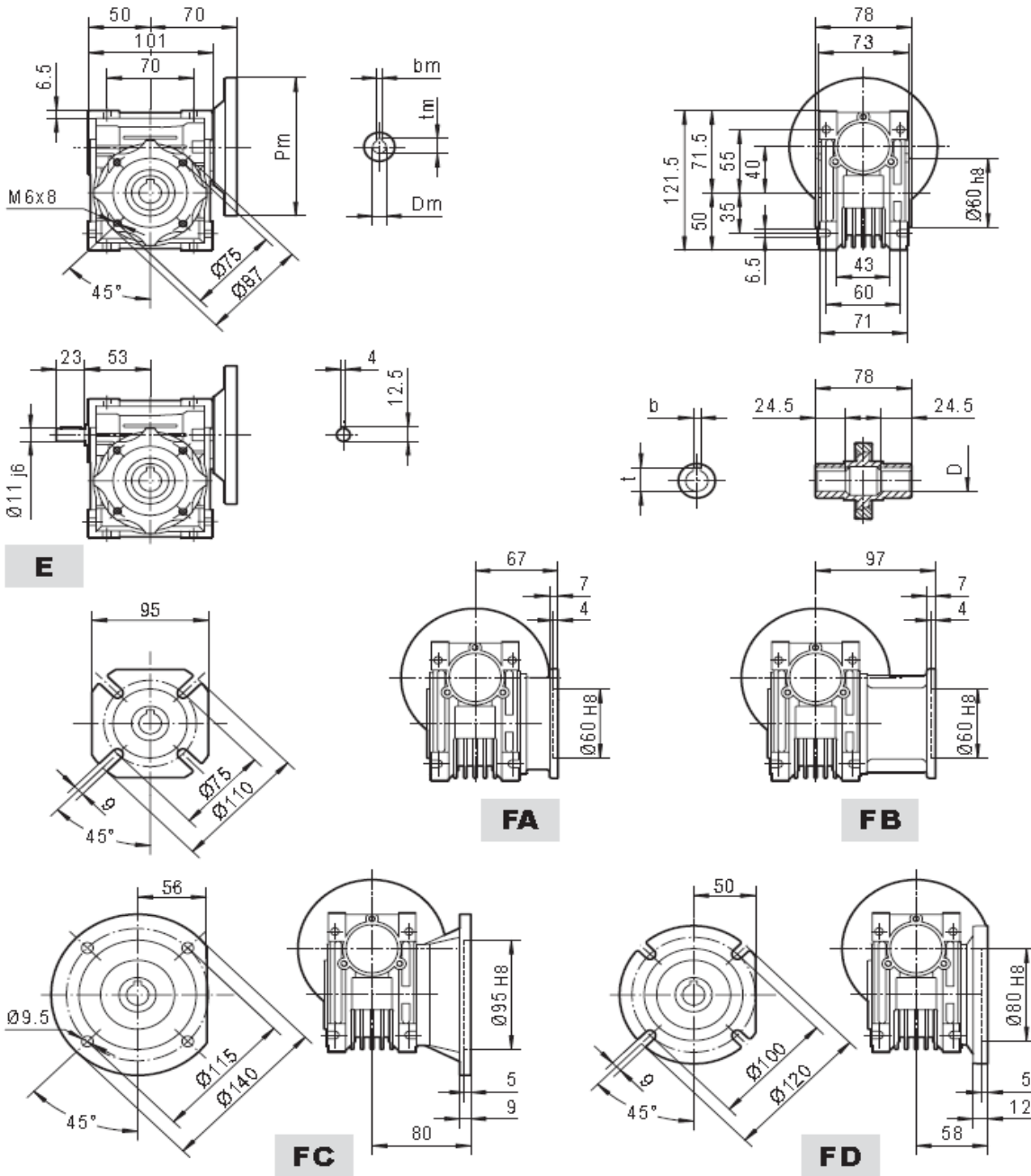

Worm Gear Units



DIMENSIONS FCNDK40



PAM IEC	Pm	Dm	bm	tm	D H8	b	t
71B5	160	14	5	16.3	18	6	20.8
63B5	140	11	4	12.8	19*	6	21.8
56B5	120	9**	3	10.4	* Only on request ** Requires reducing sleeve		
71B14	105	14	5	16.3			
63B14	90	11	4	12.8			

Weight without motor = 2.3 Kg