



OPTIDRIVE™

AC Variable Speed Drive

IP66 (NEMA 4X)

0.37kW – 22kW / 0.5HP – 30HP

110V & 230V Single Phase input,

230V & 480V 3 Phase input

Switched

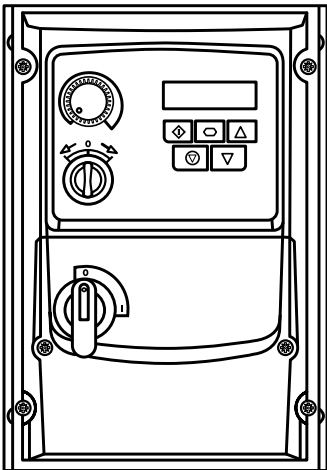

Non-switched

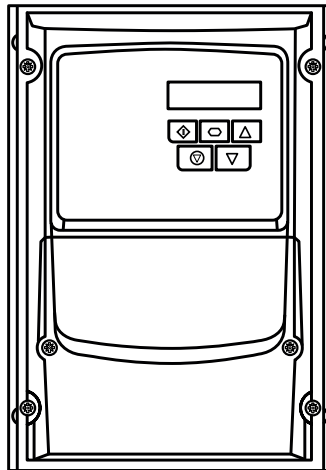

3 MOUNT

Mechanical Dimensions

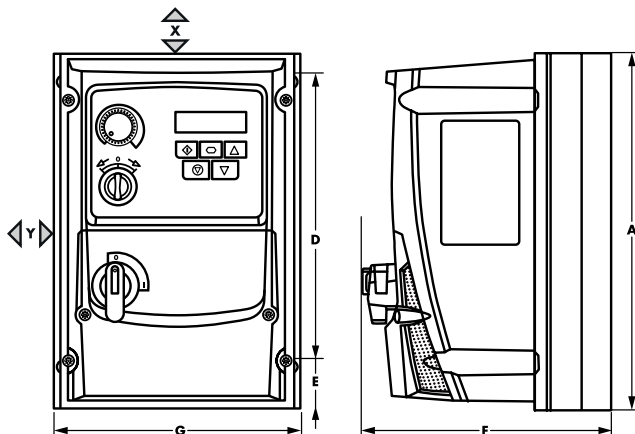

Dimensions

| Drive Size | A | | D | | E | | F | | G | |
|------------|-------|-------|-------|------|------|------|-------|-------|-------|------|
| | mm | in | mm | in | mm | in | mm | in | mm | in |
| 1 | 232.0 | 9.13 | 189.0 | 7.44 | 25.0 | 0.98 | 162.0 | 6.37 | 161.0 | 6.34 |
| 2 | 257.0 | 10.12 | 200.0 | 7.87 | 28.5 | 1.12 | 182.0 | 7.16 | 188.0 | 7.40 |
| 3 | 310.0 | 12.20 | 251.5 | 9.90 | 33.4 | 1.31 | 238.0 | 9.37 | 211.0 | 8.30 |
| 4 | 360.0 | 14.17 | 300.0 | 11.8 | 33.4 | 1.31 | 275.0 | 10.82 | 240.0 | 9.44 |

Weight

| Drive Size | Weight | |
|------------|--------|------|
| | kg | lb |
| 1 | 2.5 | 5.5 |
| 2 | 3.5 | 7.7 |
| 3 | 7.0 | 15.4 |
| 4 | 9.5 | 20.9 |

Mounting Clearance

| Drive Size | X Above & Below | | Y Either Side | |
|-----------------|-----------------|------|---------------|------|
| | mm | in | mm | in |
| All Frame Sizes | 200 | 7.87 | 10 | 0.39 |

NOTE Typical drive heat losses are approximately 3% of operating load conditions. Above are guidelines only and the operating ambient temperature of the drive **MUST** be maintained at all times.

Mounting Bolts & Tightening Torques

| Mounting Bolts | | Tightening Torques | | |
|-----------------|-------------|--------------------|-------------------|-------------------|
| Frame Size | | Frame Size | Control Terminals | Power Terminals |
| All Frame Sizes | 4 x M4 (#8) | All Frame Sizes | 0.8 Nm (7 lb-in) | 1.5 Nm (13 lb-in) |

Cable Selection

- For 1 phase supply (Sizes 1-3 only), the mains power cables should be connected to L1/L, L2/N.
- For 3 phase supplies, the mains power cables should be connected to L1, L2, and L3. Phase sequence is not important.
- For compliance with CE and C Tick EMC requirements, refer to online documentation.
- A fixed installation is required according to IEC61800-5-1 with a suitable disconnecting device installed between the Optidrive and the AC Power Source. The disconnecting device must conform to the local safety code / regulations (e.g. within Europe, EN60204-1, Safety of machinery).
- The cables should be dimensioned according to any local codes or regulations. Maximum dimensions are given in the Rating Tables section of this Quick Start Guide.

Install the Wiring

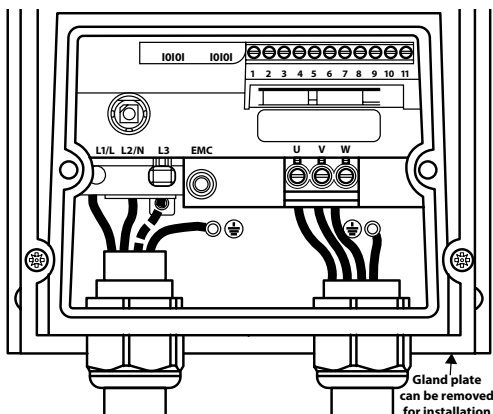

| Drive Size | Cable Gland Sizes | | |
|------------|-------------------|--------------|----------------|
| | Power Cable | Motor Cable | Control Cables |
| 1 | M20 (PG13.5) | M20 (PG13.5) | M20 (PG13.5) |
| 2 | M25 (PG21) | M25 (PG21) | M20 (PG13.5) |
| 3 | M25 (PG21) | M25 (PG21) | M20 (PG13.5) |
| 4 | M32 (PG29) | M32 (PG29) | M20 (PG13.5) |

Motor Terminal Box Connections

Most general purpose motors are wound for operation on dual voltage supplies. This is indicated on the nameplate of the motor. This operational voltage is normally selected when installing the motor by selecting either STAR or DELTA connection. STAR always gives the higher of the two voltage ratings.

| Incoming Supply Voltage | Motor Nameplate Voltages | | Connection |
|-------------------------|--------------------------|-------|------------|
| 230 | 230 / 400 | Delta | |
| 400 | 400 / 690 | | |
| 400 | 230 / 400 | Star | |

Information for UL Compliance

Optidrive E3 is designed to meet the UL requirements. For an up to date list of UL compliant products, please refer to UL listing NMMS.E226333. In order to ensure full compliance, the following must be fully observed.

| Input Power Supply Requirements | |
|--|---|
| Supply Voltage | 200 – 240 RMS Volts for 230 Volt rated units, + / - 10% variation allowed. 240 Volt RMS Maximum. 380 – 480 Volts for 400 Volt rated units, + / - 10% variation allowed, Maximum 500 Volts RMS. |
| Frequency | 50 – 60Hz + / - 5% Variation |
| Short Circuit Capacity | All drives are suitable for use on a circuit capable of delivering not more than 100kA maximum short-circuit Amperes symmetrical with the specified maximum supply voltage when protected by Class J fuses. |
| Mechanical Installation Requirements | |
| All Optidrive E3 units are intended for installation within controlled environments which meet the condition limits shown in the Environment section of this Quick Start Guide. | |
| The drive can be operated within an ambient temperature range as stated in the Environment section of this Quick Start Guide. | |
| For IP66 (Nema 4X) units, installation in a pollution degree 2 environment is permissible. | |
| Electrical Installation Requirements | |
| Incoming power supply connection must be according to the Install the Wiring section of this Quick Start Guide. | |
| Suitable power and motor cables should be selected according to the data shown in Rating Tables section of this Quick Start Guide and the National Electrical Code or other applicable local codes. | |
| Motor Cable | 75°C Copper must be used. |
| Power cable connections and tightening torques are shown in the Mechanical Dimensions section of this Quick Start Guide. | |
| Integral Solid State short circuit protection does not provide branch circuit protection. Branch circuit protection must be provided in accordance with the national electrical code and any additional local codes. Ratings are shown in the Rating Tables section of this Quick Start Guide. | |
| For Canadian installations transient surge suppression must be installed on the line side of this equipment and shall be rated 480Volt (phase to ground), 480 Volt (phase to phase), suitable for over voltage category iii and shall provide protection for a rated impulse withstand voltage peak of 2.5kV. | |
| UL Listed ring terminals / lugs must be used for all bus bar and grounding connections. | |
| General Requirements | |
| Optidrive E3 provides motor overload protection, set at 150% of full load, in accordance with the National Electrical Code (US). Where a motor thermistor is not fitted, or not utilised, Thermal Overload Memory Retention must be enabled by setting P-60 = 1. Where a motor thermistor is fitted and connected to the drive, connection must be carried out according to the information shown in the Motor Thermistor Connection section of the Quick Start Guide. | |
| UL rated ingress protection ("Type") is only met when cables are installed using a UL recognized bushing or fitting for a flexible conduit system which meets the required level of protection ("Type"). | |
| For conduit installations the conduit entry holes require standard opening to the required sizes specified per the NEC. | |
| Not intended for installation using rigid conduit system. | |
| WARNING: The opening of the branch-circuit protective device may be an indication that a fault has been interrupted. To reduce the risk of fire or electric shock, current-carrying parts and other components of the controller should be examined and replaced if damaged. If burnout of the current element of an overload relay occurs, the complete overload relay must be replaced. | |

Control Terminal Wiring

- All analog signal cables should be suitably shielded. Twisted pair cables are recommended.
- Power and Control Signal cables should be routed separately where possible, and must not be routed parallel to each other.
- Signal levels of different voltages e.g. 24 Volt DC and 110 Volt AC, should not be routed in the same cable.
- Maximum control terminal tightening torque is 0.5Nm.
- Control Cable entry conductor size: 0.05 – 2.5mm² / 30 – 12 AWG.

Control Terminal Connections

Switched Units: May use the built in control switch and potentiometer, or external control signals connected to the control terminals.

Non-Switched Units: Require external control signals to be connected to the control terminals.

Switched Units: Default functions of the control switches

| Switch Position | | | POT | Notes |
|-----------------|------|-------------|---------------------------|--|
| | | | | Factory Default Configuration. Run Forward or Reverse with speed controlled from the Local POT. |
| Run Reverse | STOP | Run Forward | Sets the output frequency | |

NOTE Other functions are possible, please refer to the online documentation for additional information.

Using the Control Terminals

| Control Terminals | | | | | | | | | | |
|-------------------|--|-----|---------|---------|---------|---|----|----|-----|-----|
| 1 | 2 | 3 | 4 | 5 | 6 | 7 | 8 | 9 | 10 | 11 |
| +24 VDC | DI1 | DI2 | DI3 AI2 | +10 VDC | DI4 AI1 | OV | AO | OV | RL1 | RL2 |
| No. | Purpose | | | | | Function | | | | |
| 1 | +24VDC 100mA Output | | | | | 24 VDC Output | | | | |
| 2 | DI1 Digital Input 1 | | | | | Function defined by P-12 & P-15. | | | | |
| 3 | DI2 Digital Input 2 | | | | | See below for further info | | | | |
| 4 | DI3 Digital Input 3/AI2 Analog Input 2 | | | | | | | | | |
| 5 | +10VDC 10mA Output | | | | | 10 VDC Output for external potentiometer | | | | |
| 6 | DI4 Digital Input 4/AI1 Analog Input 1 | | | | | Function defined by P-12 & P-15. Signal format selected by P-16 | | | | |
| 7 | OVDC Common | | | | | | | | | |
| 8 | AO Analog Output/Digital Output | | | | | Function selected by P-25. See Parameter List | | | | |
| 9 | OVDC Common | | | | | | | | | |
| 10 | RL1 Output Relay | | | | | | | | | |
| 11 | RL2 Output Relay | | | | | Function defined by P-18. See Parameter List | | | | |

Connection Example

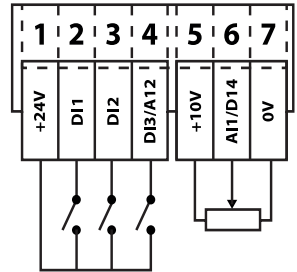

Factory Default Functions

| No. | Description | Function |
|-----|---------------------------------------|--|
| DI1 | 0/1 | Open : Stop Closed : Run |
| DI2 | ↻/↺ | Open : Forward Rotation Closed : Reverse Rotation |
| DI3 | Analog Speed Reference / Preset Speed | Open : Speed Reference set by Analog Speed Reference Closed : Speed Reference set by Preset Speed 1 (P-20) |
| AI1 | Analog Speed Reference Input | Sets the Speed Reference NOTE For Switched units, the internal pot is selected by default in P-16. For Non-switched units, an external pot or 0 - 10 V reference may be connected. Other signal types may also be used, set P-16 to the correct format. |

NOTE Additional functions are possible, refer to the online documentation for further information.

Motor Thermistor Connection

Where a motor thermistor is to be used, it should be connected as follows:

| Control Terminal Strip | Additional Information |
|------------------------|---|
| | Compatible Thermistor: PTC Type, 2.5kΩ trip level. <ul style="list-style-type: none"> Use a setting of P-15 that has Input 3 function as External Trip, e.g. P-15 = 3. Refer to online documentation for further details. Set P-47 = "Ptc-t-h" |

6 POWER ON

7 COMMISSION

Operation

Managing the Keypad

The drive is configured and its operation monitored via the keypad and display.

| | | |
|--|-------|--|
| | START | When in keypad mode, used to Start a stopped drive or to reverse the direction of rotation if bi-directional keypad mode is enabled. |
| | UP | Used to increase speed in real-time mode or to increase parameter values in parameter edit mode. |

| | | |
|--|--------------|---|
| | DOWN | Used to decrease speed in real-time mode or to decrease parameter values in parameter edit mode. |
| | NAVIGATE | Used to display real-time information, to access and exit parameter edit mode and to store parameter changes. |
| | RESET / STOP | Used to reset a tripped drive. When in Keypad mode is used to Stop a running drive. |

Operating Displays

| | | | | |
|--------------------------|---|---|---|--|
| | | | | |
| Drive Stopped / Disabled | Drive is enabled / running, display shows the output frequency (Hz) | Press the Navigate key for < 1 second. The display will show the motor current (Amps) | Press the Navigate key for < 1 second. The display will show the motor power (kW) | If P-10 > 0, pressing the Navigate key for < 1 second will display the motor speed (RPM) |

Changing Parameters

| | | | | | |
|---|---|---------------------------------------|---|--|--|
| | | | | | |
| Press and hold the Navigate key > 2 seconds | Use the up and down keys to select the required parameter | Press the Navigate key for < 1 second | Adjust the value using the Up and Down keys | Press for < 1 second to return to the parameter menu | Press for > 2 seconds to return to the operating display |

Read Only Parameter Access

| | | | | | |
|---|---|---------------------------------------|---|--|--|
| | | | | | |
| Press and hold the Navigate key > 2 seconds | Use the up and down keys to select P-00 | Press the Navigate key for < 1 second | Use the up and down keys to select the required Read Only parameter | Press the Navigate key for < 1 second to display the value | Press and hold the Navigate key > 2 seconds to return to the operating display |

Resetting Parameters

| | |
|--|--|
| | |
| To reset parameter values to their factory default settings, press and hold Up, Down and Stop buttons for > 2 seconds. The display will show "P-dEF" | Press the Stop key. The display will show "StOP" |

Resetting a Fault

| | |
|--|--|
| | |
| Press the Stop key. The display will show "StOP" | |

8 OPERATE

Parameters

Standard Parameters

| Par. | Description | Min | Max | Default | Units | | | | | | | | | | | | | | | | | | | | | | | | |
|--|--|---|---------------------------|-------------------------------|--|---------------------|---|---|---------|----------|----------|---------------------|---|---|--|---|----------|---------------------|----------------------------|---|-----|------|----------|-------|----------------------------|--|--|--|--|
| P-01 | Maximum Frequency/ Speed Limit | P-02 | 500.0 | 50.0 (60.0) | Hz/RPM | | | | | | | | | | | | | | | | | | | | | | | | |
| P-02 | Minimum Frequency/Speed Limit | 0.0 | P-01 | 0.0 | Hz/RPM | | | | | | | | | | | | | | | | | | | | | | | | |
| P-03 | Acceleration Ramp Time | 0.00 | 600.0 | 5.0 | s | | | | | | | | | | | | | | | | | | | | | | | | |
| P-04 | Deceleration Ramp Time | 0.00 | 600.0 | 5.0 | s | | | | | | | | | | | | | | | | | | | | | | | | |
| P-05 | Stopping Mode/ Mains Loss Response | 0 | 4 | 0 | - | | | | | | | | | | | | | | | | | | | | | | | | |
| <table border="1"> <thead> <tr> <th>Setting</th> <th>On Disable</th> <th>On Mains Loss</th> </tr> </thead> <tbody> <tr> <td>0</td> <td>Ramp to Stop (P-04)</td> <td>Ride Through (Recover energy from load to maintain operation)</td> </tr> <tr> <td>1</td> <td>Coast</td> <td>Coast</td> </tr> <tr> <td>2</td> <td>Ramp to Stop (P-04)</td> <td>Fast Ramp to Stop (P-24), Coast if P-24 = 0</td> </tr> <tr> <td>3</td> <td>Ramp to Stop (P-04) with AC Flux Braking</td> <td>Fast Ramp to Stop (P-24), Coast if P-24 = 0</td> </tr> <tr> <td>4</td> <td>Ramp to Stop (P-04)</td> <td>No action</td> </tr> </tbody> </table> | | Setting | On Disable | On Mains Loss | 0 | Ramp to Stop (P-04) | Ride Through (Recover energy from load to maintain operation) | 1 | Coast | Coast | 2 | Ramp to Stop (P-04) | Fast Ramp to Stop (P-24), Coast if P-24 = 0 | 3 | Ramp to Stop (P-04) with AC Flux Braking | Fast Ramp to Stop (P-24), Coast if P-24 = 0 | 4 | Ramp to Stop (P-04) | No action | | | | | | | | | | |
| Setting | On Disable | On Mains Loss | | | | | | | | | | | | | | | | | | | | | | | | | | | |
| 0 | Ramp to Stop (P-04) | Ride Through (Recover energy from load to maintain operation) | | | | | | | | | | | | | | | | | | | | | | | | | | | |
| 1 | Coast | Coast | | | | | | | | | | | | | | | | | | | | | | | | | | | |
| 2 | Ramp to Stop (P-04) | Fast Ramp to Stop (P-24), Coast if P-24 = 0 | | | | | | | | | | | | | | | | | | | | | | | | | | | |
| 3 | Ramp to Stop (P-04) with AC Flux Braking | Fast Ramp to Stop (P-24), Coast if P-24 = 0 | | | | | | | | | | | | | | | | | | | | | | | | | | | |
| 4 | Ramp to Stop (P-04) | No action | | | | | | | | | | | | | | | | | | | | | | | | | | | |
| P-06 | Energy Optimiser | 0 | 3 | 0 | - | | | | | | | | | | | | | | | | | | | | | | | | |
| <table border="1"> <thead> <tr> <th>Setting</th> <th>Motor Energy Optimisation</th> <th>Optidrive Energy Optimisation</th> </tr> </thead> <tbody> <tr> <td>0</td> <td>Disabled</td> <td>Disabled</td> </tr> <tr> <td>1</td> <td>Enabled</td> <td>Disabled</td> </tr> <tr> <td>2</td> <td>Disabled</td> <td>Enabled</td> </tr> <tr> <td>3</td> <td>Enabled</td> <td>Enabled</td> </tr> </tbody> </table> | | Setting | Motor Energy Optimisation | Optidrive Energy Optimisation | 0 | Disabled | Disabled | 1 | Enabled | Disabled | 2 | Disabled | Enabled | 3 | Enabled | Enabled | | | | | | | | | | | | | |
| Setting | Motor Energy Optimisation | Optidrive Energy Optimisation | | | | | | | | | | | | | | | | | | | | | | | | | | | |
| 0 | Disabled | Disabled | | | | | | | | | | | | | | | | | | | | | | | | | | | |
| 1 | Enabled | Disabled | | | | | | | | | | | | | | | | | | | | | | | | | | | |
| 2 | Disabled | Enabled | | | | | | | | | | | | | | | | | | | | | | | | | | | |
| 3 | Enabled | Enabled | | | | | | | | | | | | | | | | | | | | | | | | | | | |
| P-07 | Motor Rated Voltage/ Back EMF at rated speed (PM/BLDC) | 0 | 250/ 500 | 230/400 | V | | | | | | | | | | | | | | | | | | | | | | | | |
| P-08 | Motor Rated Current | Drive Rating Dependent | | | A | | | | | | | | | | | | | | | | | | | | | | | | |
| P-09 | Motor Rated Frequency | 10 | 500 | 50 (60) | Hz | | | | | | | | | | | | | | | | | | | | | | | | |
| P-10 | Motor Rated Speed | 0 | 30000 | 0 | RPM | | | | | | | | | | | | | | | | | | | | | | | | |
| P-11 | Low Frequency Torque Boost | 0.0 | Drive Dependent | | % | | | | | | | | | | | | | | | | | | | | | | | | |
| P-12 | Primary Command Source | 0 | 9 | 0 | - | | | | | | | | | | | | | | | | | | | | | | | | |
| <p>0: Terminal Control</p> <p>1: Uni-directional Keypad Control</p> <p>2: Bi-directional Keypad Control</p> <p>3: Modbus Network Control</p> <p>4: Modbus Network Control</p> | | <p>5: PI Control</p> <p>6: PI Analog Summation Control</p> <p>7: CAN Control</p> <p>8: CAN Control</p> <p>9: Slave Mode</p> <p>NOTE When P-12 = 1, 2, 3, 4, 7, 8 or 9, an enable signal must still be provided at the control terminals, digital input 1.</p> | | | | | | | | | | | | | | | | | | | | | | | | | | | |
| P-13 | Operating Mode Select | 0 | 2 | 0 | - | | | | | | | | | | | | | | | | | | | | | | | | |
| <p>0: Industrial Mode 1: Pump Mode 2: Fan Mode</p> <table border="1"> <thead> <tr> <th>Setting</th> <th>Application</th> <th>Current Limit (P-54)</th> <th>Torque Characteristic</th> <th>Spin Start (P-33)</th> <th>Thermal Overload Limit Reaction (P-60 Index 2)</th> </tr> </thead> <tbody> <tr> <td>0</td> <td>General</td> <td>150%</td> <td>Constant</td> <td>0: Off</td> <td>0: Trip</td> </tr> <tr> <td>1</td> <td>Pump</td> <td>110%</td> <td>Variable</td> <td>0: Off</td> <td>1: Current Limit Reduction</td> </tr> <tr> <td>2</td> <td>Fan</td> <td>110%</td> <td>Variable</td> <td>2: On</td> <td>1: Current Limit Reduction</td> </tr> </tbody> </table> | | Setting | Application | Current Limit (P-54) | Torque Characteristic | Spin Start (P-33) | Thermal Overload Limit Reaction (P-60 Index 2) | 0 | General | 150% | Constant | 0: Off | 0: Trip | 1 | Pump | 110% | Variable | 0: Off | 1: Current Limit Reduction | 2 | Fan | 110% | Variable | 2: On | 1: Current Limit Reduction | | | | |
| Setting | Application | Current Limit (P-54) | Torque Characteristic | Spin Start (P-33) | Thermal Overload Limit Reaction (P-60 Index 2) | | | | | | | | | | | | | | | | | | | | | | | | |
| 0 | General | 150% | Constant | 0: Off | 0: Trip | | | | | | | | | | | | | | | | | | | | | | | | |
| 1 | Pump | 110% | Variable | 0: Off | 1: Current Limit Reduction | | | | | | | | | | | | | | | | | | | | | | | | |
| 2 | Fan | 110% | Variable | 2: On | 1: Current Limit Reduction | | | | | | | | | | | | | | | | | | | | | | | | |
| P-14 | Extended Menu Access code | 0 | 65535 | 0 | - | | | | | | | | | | | | | | | | | | | | | | | | |

Extended Parameters

| Par. | Description | Min | Max | Default | Units |
|------|---|---|--------|---------|--------|
| P-15 | Digital Input Function Select | 0 | 17 | 0 | - |
| P-16 | Analog Input 1 Signal Format | See Below | | U0-10 | - |
| | U 0-10 : Unidirectional, External 0 – 10Volt reference / pot b 0-10 : Bi-directional, External 0 – 10Volt reference / pot R 0-20 : External 0 – 20mA signal t 4-20 : External 4-20mA signal, trip on loss r 4-20 : External 4 – 20mA signal | t 20-4 : External 20 – 4mA signal, trip on loss r 20-4 : External 20 – 4mA signal U 10-0 : External 10 – 0 Volt signal I n-Pot : Switched units only : Internal pot | | | |
| P-18 | Output Relay Function Select | 0 | 9 | 1 | - |
| | 0: Drive Enabled (Running) 1: Drive Healthy 2: At Target Frequency (Speed) 3: Drive Tripped 4: Output Frequency >= Limit | 5: Output Current >= Limit 6: Output Frequency < Limit 7: Output Current < Limit 8: Analog Input 2 > Limit 9: Drive Ready to Run | | | |
| P-20 | Preset Frequency / Speed 1 | -P-01 | P-01 | 5.0 | Hz/RPM |
| P-21 | Preset Frequency / Speed 2 | -P-01 | P-01 | 25.0 | Hz/RPM |
| P-22 | Preset Frequency / Speed 3 | -P-01 | P-01 | 40.0 | Hz/RPM |
| P-23 | Preset Frequency / Speed 4 | -P-01 | P-01 | P-09 | Hz/RPM |
| P-24 | 2nd Ramp Time (Fast Stop) | 0.00 | 600.0 | 0.00 | s |
| P-25 | Analog Output Function Select | 0 | 11 | 8 | - |
| | Digital Output Mode. Logic 1 = +24V DC 0: Drive Enabled (Running) 1: Drive Healthy 2: At Target Frequency (Speed) 3: Drive Tripped 4: Output Frequency >= Limit 5: Output Current >= Limit 6: Output Frequency < Limit 7: Output Current < Limit | Analog Output Mode 8: Output Frequency (Motor Speed) 9: Output (Motor) Current 10: Output Power 11: Load Current | | | |
| P-31 | Keypad Start Mode Select | 0 | 7 | 1 | - |
| | 0: Minimum Speed, Keypad Start 1: Previous Speed, Keypad Start 2: Minimum Speed, Terminal Enable 3: Previous Speed, Terminal Enable | 4: Current Speed, Keypad Start 5: Preset Speed 4, Keypad Start 6: Current Speed, Terminal Start 7: Preset Speed 4, Terminal Start | | | |
| P-33 | Spin Start | 0 | 2 | 0 | - |
| | 0: Disabled 1: Enabled 2: Enabled on Trip, Brown Out or Coast Stop | | | | |
| P-34 | Brake Chopper Enable (Not Size 1) | 0 | 4 | 0 | - |
| | 0: Disabled 1: Enabled With Software Protection 2: Enabled Without Software Protection | 3: Enabled With Software Protection 4: Enabled Without Software Protection | | | |
| P-38 | Parameter Access Lock | 0 | 1 | 0 | - |
| | 0: Unlocked 1: Locked | | | | |
| P-39 | Analog Input 1 Offset | -500.0 | 500.0 | 0.0 | % |
| P-40 | Index 1: Display Scaling Factor | 0.000 | 16.000 | 0.000 | - |
| | Index 2: Display Scaling Source | 0 | 3 | 0 | - |
| P-41 | PI Controller Proportional Gain | 0.0 | 30.0 | 1.0 | - |
| P-42 | PI Controller Integral Time | 0.0 | 30.0 | 1.0 | s |

| Par. | Description | Min | Max | Default | Units |
|------|--|---|---|------------|--------------|
| P-43 | PI Controller Operating Mode | 0 | 3 | 0 | - |
| | 0: Direct Operation 1: Inverse Operation | 2: Direct Operation, Wake at Full Speed 3: Reverse Operation, Wake at Full Speed | | | |
| P-44 | PI Reference (Setpoint) Source Select | 0 | 1 | 0 | - |
| | 0: Digital Preset Setpoint | 1: Analog Input 1 Setpoint | | | |
| P-45 | PI Digital Setpoint | 0.0 | 100.0 | 0.0 | % |
| P-46 | PI Feedback Source Select | 0 | 5 | 0 | - |
| | 0: Analog Input 2 1: Analog Input 1 | 2: Motor Current 3: DC Bus Voltage | 4: Analog 1 - Analog 2 5: Largest (Analog 1, Analog 2) | | |
| P-47 | Analog Input 2 Signal Format | - | - | - | U0-10 |
| | <i>U</i> 0-10 : Unidirectional, External 0 – 10Volt reference / pot | <i>t</i> 20-4 : External 20 – 4mA signal, trip on loss | | | |
| | <i>R</i> 0-20 : External 0 – 20mA signal | <i>r</i> 20-4 : External 20 – 4mA signal | | | |
| | <i>t</i> 4-20 : External 4-20mA signal, trip on loss <i>r</i> 4-20 : External 4 – 20mA signal | <i>Ptc-th</i> : Motor thermistor | | | |
| P-48 | Standby Mode Timer | 0.0 | 25.0 | 0.0 | s |
| P-49 | PI Control Wake Up Error Level | 0.0 | 100.0 | 5.0 | % |
| P-50 | User Output Relay Hysteresis | 0.0 | 100.0 | 0.0 | % |

Advanced Parameters

| Par. | Description | Min | Max | Default | Units |
|------|--|---|----------|----------|----------|
| P-51 | Motor Control Mode | 0 | 5 | 0 | - |
| | 0: Vector speed control mode 1: V/f mode 2: PM motor vector speed control | 3: BLDC motor vector speed control 4: Synchronous Reluctance motor vector speed control 5: LSPM motor vector speed control | | | |
| | 0: Disabled 1: Enabled | | | | |
| P-52 | Motor Parameter Autotune | 0 | 1 | 0 | - |

Technical Data

Environment

Operational ambient temperature range

Enclosed Drives: -20 ... 40°C (frost and condensation free)

Storage ambient temperature range: -40 ... 60°C

Maximum altitude: 2000m. Derate above 1000m: 1% / 100m

Maximum humidity: 95%, non-condensing

Rating Tables

| Frame Size | kW | HP | Input Current | Fuse/ MCB (Type B) | | Maximum Cable Size | | Output Current A | Recommended Brake Resistance Ω |
|---|------|-----|---------------|--------------------|------|--------------------|-----|---------------------|-----------------------------------|
| | | | | Non UL | UL | mm | AWG | | |
| 110 - 115 (+ / - 10%) V 1 Phase Input, 230V 3 Phase Output (Voltage Doubler) | | | | | | | | | |
| 1 | 0.37 | 0.5 | 7.8 | 10 | 10 | 8 | 8 | 2.3 | - |
| 1 | 0.75 | 1 | 15.8 | 25 | 20 | 8 | 8 | 4.3 | - |
| 2 | 1.1 | 1.5 | 21.9 | 32 | 30 | 8 | 8 | 5.8 | 100 |
| 200 - 240 (+ / - 10%) V 1 Phase Input, 3 Phase Output | | | | | | | | | |
| 1 | 0.37 | 0.5 | 3.7 | 10 | 6 | 8 | 8 | 2.3 | - |
| 1 | 0.75 | 1 | 7.5 | 10 | 10 | 8 | 8 | 4.3 | - |
| 1 | 1.5 | 2 | 12.9 | 16 | 17.5 | 8 | 8 | 7 | - |
| 2 | 1.5 | 2 | 12.9 | 16 | 17.5 | 8 | 8 | 7 | 100 |
| 2 | 2.2 | 3 | 19.2 | 25 | 25 | 8 | 8 | 10.5 | 50 |
| 3 | 4 | 5 | 29.2 | 40 | 40 | 8 | 8 | 15.3 | 25 |
| 200 - 240 (+ / - 10%) V 3 Phase Input, 3 Phase Output | | | | | | | | | |
| 1 | 0.37 | 0.5 | 3.4 | 6 | 6 | 8 | 8 | 2.3 | - |
| 1 | 0.75 | 1 | 5.6 | 10 | 10 | 8 | 8 | 4.3 | - |
| 1 | 1.5 | 2 | 8.9 | 16 | 15 | 8 | 8 | 7 | - |
| 2 | 1.5 | 2 | 8.9 | 16 | 15 | 8 | 8 | 7 | 100 |
| 2 | 2.2 | 3 | 12.1 | 16 | 17.5 | 8 | 8 | 10.5 | 50 |
| 3 | 4 | 5 | 20.9 | 32 | 30 | 8 | 8 | 18 | 25 |
| 3 | 5.5 | 7.5 | 26.4 | 40 | 35 | 8 | 8 | 24 | 20 |
| 4 | 7.5 | 10 | 33.3 | 40 | 45 | 16 | 5 | 30 | 15 |
| 4 | 11 | 15 | 50.1 | 63 | 70 | 16 | 5 | 46 | 10 |
| 380 - 480 (+ / - 10%) V 3 Phase Input, 3 Phase Output | | | | | | | | | |
| 1 | 0.75 | 1 | 3.5 | 6 | 6 | 8 | 8 | 2.2 | - |
| 1 | 1.5 | 2 | 5.6 | 10 | 10 | 8 | 8 | 4.1 | - |
| 2 | 1.5 | 2 | 5.6 | 10 | 10 | 8 | 8 | 4.1 | 250 |
| 2 | 2.2 | 3 | 7.5 | 16 | 10 | 8 | 8 | 5.8 | 200 |
| 2 | 4 | 5 | 11.5 | 16 | 15 | 8 | 8 | 9.5 | 120 |
| 3 | 5.5 | 7.5 | 17.2 | 25 | 25 | 8 | 8 | 14 | 100 |
| 3 | 7.5 | 10 | 21.2 | 32 | 30 | 8 | 8 | 18 | 80 |
| 3 | 11 | 15 | 27.5 | 40 | 35 | 8 | 8 | 24 | 50 |
| 4 | 15 | 20 | 34.2 | 40 | 45 | 16 | 5 | 30 | 30 |
| 4 | 18.5 | 25 | 44.1 | 50 | 60 | 16 | 5 | 39 | 22 |
| 4 | 22 | 30 | 51.9 | 63 | 70 | 16 | 5 | 46 | 22 |

NOTE Cable sizes shown are the maximum possible that may be connected to the drive. Cables should be selected according to local wiring codes or regulations at the point of installation.

Troubleshooting

Fault Code Messages

| Fault Code | No. | Description |
|--------------------|-----|-------------------------------------|
| <i>01 - b</i> | 01 | Brake channel over current |
| <i>0L - br</i> | 02 | Brake resistor overload |
| <i>0 - I</i> | 03 | Output Over Current |
| <i>I - t - trP</i> | 04 | Motor Thermal Overload (I2t) |
| <i>0 - uOLt</i> | 06 | Over voltage on DC bus |
| <i>U - uOLt</i> | 07 | Under voltage on DC bus |
| <i>0 - t</i> | 08 | Heatsink over temperature |
| <i>U - t</i> | 09 | Under temperature |
| <i>E - tr iP</i> | 11 | External trip |
| <i>5C - 0b5</i> | 12 | Optibus comms loss |
| <i>F Lt - dc</i> | 13 | DC bus ripple too high |
| <i>P - LOSS</i> | 14 | Input phase loss trip |
| <i>h 0 - I</i> | 15 | Output Over Current |
| <i>t h - F Lt</i> | 16 | Faulty thermistor on heatsink |
| <i>dRAr - F</i> | 17 | Internal memory fault (IO) |
| <i>4 - 20 F</i> | 18 | 4-20mA Signal Lost |
| <i>dRAr - E</i> | 19 | Internal memory fault (DSP) |
| <i>F - Ptc</i> | 21 | Motor PTC thermistor trip |
| <i>FAr - F</i> | 22 | Cooling Fan Fault (IP66 only) |
| <i>0 - hERt</i> | 23 | Drive internal temperature too high |
| <i>0Ut - F</i> | 26 | Output Fault |
| <i>RtF - 02</i> | 41 | Autotune Fault |
| <i>5C - F0 I</i> | 50 | Modbus comms loss fault |
| <i>5C - F02</i> | 51 | CAN comms loss trip |

NOTE Following an over current or overload trip (1, 3, 4, 15), the drive may not be reset until the reset time delay has elapsed to prevent damage to the drive.



82-E3166-IN_V1.05

Invertek Drives Ltd. Offa's Dyke Business Park, Welshpool, Powys SY21 8JF United Kingdom

Tel: +44 (0)1938 556868 Fax: +44 (0)1938 556869

www.invertekdrives.com