



## OPTIDRIVE P2 ENCODER INTERFACE MODULES User Guide



### DECLARATION

All rights reserved. No part of this User Guide may be reproduced or transmitted in any form or by any means, electrical or mechanical including photocopying, recording or by any information storage or retrieval system without permission in writing from the publisher.

Copyright Invertex Drives Ltd ©2013

The manufacturer accepts no liability for any consequences resulting from inappropriate, negligent or incorrect installation.

The contents of this User Guide are believed to be correct at the time of printing. In the interests of a commitment to a policy of continuous improvement, the manufacturer reserves the right to change the specification of the product or its performance or the contents of the User Guide without notice.

### SAFETY

This option is specifically designed to be used with the Optidrive P2 variable speed drive product range and is intended for professional incorporation into complete equipment or systems. If installed incorrectly it may present a safety hazard. The Optidrive P2 uses high voltages and currents, carries a high level of stored electrical energy, and is used to control mechanical plant that may cause injury. Close attention is required to system design and electrical installation to avoid hazards in either normal operation or in the event of equipment malfunction.

System design, installation, commissioning and maintenance must be carried out only by personnel who have the necessary training and experience. They must read carefully this safety information and the instructions in this Guide and follow all information regarding transport, storage, installation and use of the Option module, including the specified environmental limitations.

Please read the SAFETY NOTICE carefully, and all Warning and Caution boxes elsewhere.

### WARRANTY

All Invertex Drives Ltd (IDL) products carry a 2-year warranty, valid from the date of manufacture.

*Complete Warranty Terms and Conditions are available upon request from your IDL Authorized Distributor.*

Part No. 82-OPT-2-ENCOD-IN  
82-OPT-2-ENCOD-IN User Manual Iss1.00

### CAUTION

• Store the Optidrive Option Module in its box until required. It should be stored in a clean and dry environment. Temperature range  $-40^{\circ}\text{C}$  to  $+60^{\circ}\text{C}$ . Install the Option Module into the Optidrive by inserting the module into the option module port of the Optidrive as shown in the mechanical installation section. Do not use undue force in inserting the option module into the port.

### SAFETY NOTICES

**WARNING** is given where there is a hazard that could lead to injury or death of personnel.

**CAUTION** is given where there is a hazard that could lead to damage to equipment.

It is the responsibility of the installer to ensure that the equipment or system into which the product is incorporated complies with the EMC legislation of the country of use. Within the European Union, equipment into which this product is incorporated must comply with 89/336/EEC, Electromagnetic Compatibility

### WARNING

Within the European Union, all machinery in which this product is used must comply with the Directive 89/392/EEC, Safety of Machinery. In particular, the equipment should comply with EN60204-1.

### WARNING

• Optidrives and the Option Modules should be installed only by qualified electrical persons and in accordance with local and national regulations and codes of practice.

• **Electric shock hazard!** Disconnect and **ISOLATE** the Optidrive before attempting any work on it. High voltages are present at the terminals and within the drive for up to 10 minutes after disconnection of the electrical supply.

• Where the electrical supply to the drive is through a plug and socket connector, do not disconnect until 10 minutes have elapsed after turning off the supply.

### STANDARDS CONFORMITY

An Optidrive fitted with this Option complies with the following standards:

- CE-marked for Low Voltage Directive.
- IEC 664-1 Insulation Coordination within Low Voltage Systems.
- UL 840 Insulation Coordination for electrical equipment.
- EN50081-2 EMC Generic Emissions Standard, Industrial Level.
- EN50082-2 EMC Generic Immunity Standard, Industrial Level.
- Enclosure ingress protection, EN60529 IP00, NEMA 250.
- Flammability rating according to UL 94.

### SPECIFICATIONS

Model Number	OPT-2-ENCOD-IN (5 Volt TTL Version)
	OPT-2-ENCHT-IN (8 – 30 Volt HTL Version)
Compatibility	Optidrive P2 (ODP-2) Drives
Compatible Encoder Type	TTL Version : 5V TTL – A & B Channel with Compliment
	HTL Version 24V HTL – A & B Channel with Compliment <i>Note: +24V HTL encoder requires external supply voltage.</i>
Power Supply Output	5V DC @ 200mA Max
Maximum Input Frequency	500kHz
Maximum Input Voltage	TTL Version : 5.5 VDC HTL Version : 30 VDC
Environmental	0°C - +50°C
Terminal Torque	0.5Nm (4.5 lb-in)

**Invertex Drives Ltd**  
**Offa's Dyke Business Park**  
**Welshpool**  
**Powys**  
**SY21 8JF**  
**UK**

Tel: +44 (0) 1938 556868  
Fax: +44 (0) 1938 556 869

email: [sales@invertex.co.uk](mailto:sales@invertex.co.uk)  
Web: [www.invertexdrives.com](http://www.invertexdrives.com)

**MECHANICAL INSTALLATION**

- Option Module inserted into Optidrive Option Module Port
- DO NOT use undue force in inserting the option module into the options port.
- Ensure the option module is fitted securely before powering on the Optidrive.
- Remove terminal block header from option module prior to tightening connections. Replace when wiring is completed. Tighten to Torque setting provided in Specifications.



**OPERATION**

Parameter Settings

When operating with an encoder, the following parameter settings are required as a minimum:

- P1-09: Motor rated frequency (found on the motor nameplate).
- P1-10: Motor rated speed (found on the motor nameplate).
- P6-06: Encoder PPR value (enter value for the connected encoder).

Closed Loop Vector speed provides full torque holding capability at zero speed and enhanced operation at frequencies below 1Hz. The drive, encoder module and encoder should be connected according to the voltage rating of the encoder as shown in the wiring diagrams.

The encoder cable should be an overall shielded type, with the shield bonded to earth at both ends.

**OPTION MODULE CONNECTION TERMINALS**

Pin	Function
1	A Channel (A)
2	A Channel Inverse (/A)
3	B Channel (B)
4	B Channel Inverse (/B)
5	+5V DC Output
6	0 Volt



**COMMISSIONING**

When commissioning, the Optidrive should firstly be commissioned in Encoderless Vector Speed Control (P6-05 = 0), and a speed / polarity check should then be made to ensure that the sign of the feedback signal matches that of the speed reference in the drive. The steps below show the suggested commissioning sequence, assuming the encoder is correctly connected to the Optidrive.

- Enter the following parameters from the motor nameplate:-
  - P1-07 – Motor Rated Voltage
  - P1-08 – Motor Rated Current
  - P1-09 – Motor Rated Frequency
  - P1-10 – Motor Rated Speed
- To enable access to the advanced parameters required, set P1-14 = 201
- Select Vector Speed Control Mode by setting P4-01 = 0
- Carry out an Auto-tune by setting P4-02 = 1
- Once the Auto-tune is completed, the Optidrive should be run in the forward direction with a low speed reference (e.g. 2 – 5Hz). Ensure the motor operates correctly and smoothly.
- Check the Encoder Feedback value in P0-58. With the Optidrive running in the forward direction, the value should be positive, and stable with variation of + / - 5% maximum. If the value in this parameter is positive, the encoder wiring is correct. If the value is negative, the speed feedback is inverted. To correct this, reverse the A and B signal channels from the encoder.
- Varying the drive output speed should then result in the value of P0-58 changing to reflect the change of the actual motor speed. If this is not the case, check the wiring of the whole system.
- If the above check is passed, the feedback control function can be enabled by setting P6-05 to 1.

*An application note, detailing full use of the Encoder interface module, is available from your local Invertek distributor.*

**Connection Example – 5V TTL Encoder OPT-2-ENCOD-IN**

**Connection Example – 24V HTL Encoder OPT-2-ENCHT-IN**

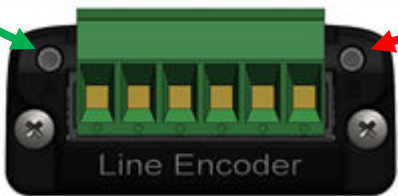
LED A (Green)      LED B (Red)

Line Encoder

**LED STATUS INDICATION**

The encoder module has 2 LEDs – LED A (Green) and LED B (Red). LED A indicates power LED B indicates a wiring fault condition.

The fault code is indicated on the drive display as noted above. For transient faults, the LED will remain illuminated for 50ms to ensure that fast transient faults can be observed.

**ERROR CODE DEFINITIONS**

The following error codes are related to the encoder operation:

Code	Description	Solution
<b>Enc-01</b>	Communication loss	No communication between the encoder module and the drive. Please check the module is properly fitted into the slot.
<b>Enc-02</b>	Speed feedback error exceeds level set in P6-07	The estimated motor speed differs from the measured motor speed. Check encoder connection, wire shielding, and values set in P6-07.
<b>Enc-03</b>	Encoder PPR motor speed mismatch	The encoder used must have a PPR value of at least 60. Motor nameplate RPM must be entered in P1-10
<b>Enc-04</b>	Encoder Channel A Fault	Error normally caused by encoder wiring error.
<b>Enc-05</b>	Encoder Channel B Fault	Check encoder wiring and commissioning guidelines.
<b>Enc-06</b>	Encoder Channels A & B Faults	